

VICOR CONFIDENTIAL

THIS DOCUMENT AND THE DATA DISCLOSED HEREIN OR HEREWITH IS NOT TO BE REPRODUCED, USED, OR DISCLOSED IN WHOLE OR IN PART TO ANYONE WITHOUT PERMISSION OF VICOR CORP.

REV.	DESCRIPTION	DATE	APPROVED
1	RELEASED PER E0430434	PEI 09/20/04	FN
2	REVISED PER E090673C	AR 04/22/09	REJH
3	REVISED PER E091595a	JS 09/10/09	REJH

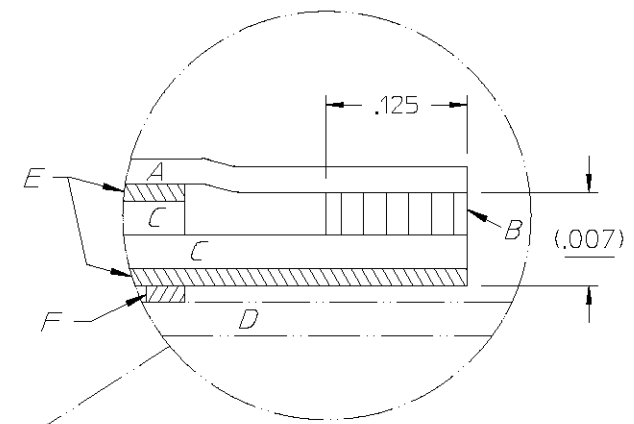
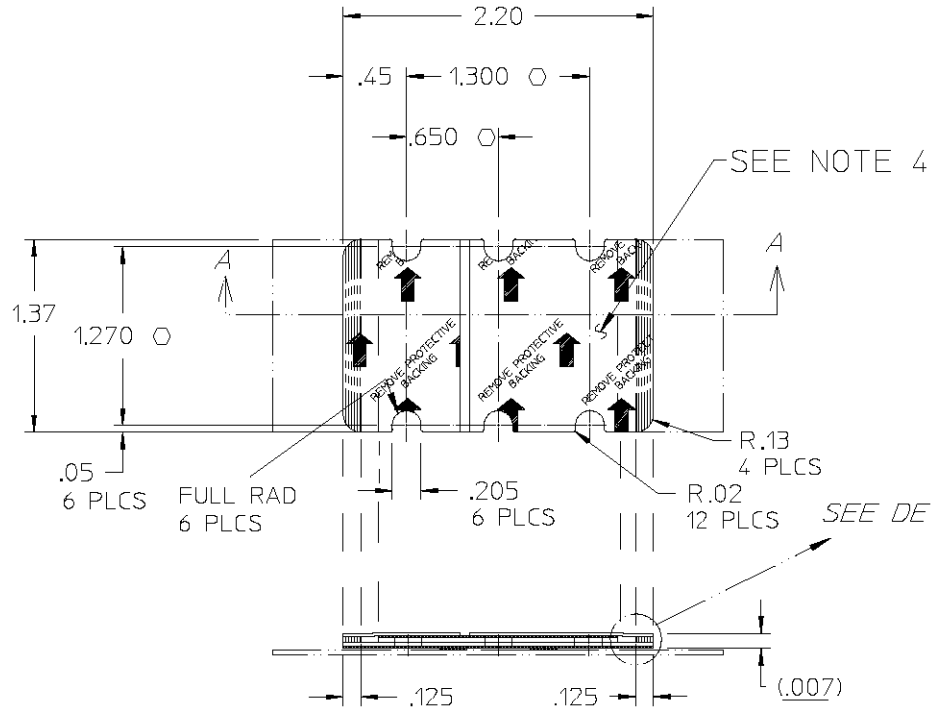

DETAIL :
 A. SPLIT RELEASE LINER.
 B. ADHESIVE STRIP; .0025 THICK .125 WIDE.
 C. ALUMINUM ALLOY 1145-0; .002 THICK.
 D. ROLL CARRIER WITH ADHESIVE STRIP BONDING.
 E. PHASE CHANGE THERMAL COMPOUND.
 F. ADHESIVE STRIPS ON ROLL CARRIER.

SECTION A-A

(VERTICAL THICKNESS IS NOT SHOWN TO SCALE)

- NOTES:
1. MATERIAL: MAKE FROM HENKEL AL-2-22H-137
 2. THICKNESS: .007±.001.
 3. SEE DETAIL FOR ASSY ORDER.
 4. FOR ARTWORK SHOWN HERE SEE DWG# 20200.
 5. O DENOTE CRITICAL CHARACTERISTIC FOR LOT INSPECTION.
 6. RoHS COMPLIANT PER CST-0001 LATEST REVISION.
 7. PRIOR TO ASSEMBLY, PRODUCTS SHALL BE STORED IN A COOL, DRY LOCATION IN ORIGINAL PACKAGING AT TEMPERATURES BELOW 40°C (104°F). UNDER THESE CONDITIONS THE SHELF LIFE IS INDEFINITE. THERMMATE PADS CAN BE PRE-APPLIED TO BASEPLATES OR HEAT SINKS WHICH ARE THEN SHIPPED TO A FINAL ASSEMBLY LOCATION, AS LONG AS THE TEMPERATURE DOES NOT EXCEED THE LEVEL INDICATED ABOVE.

DRAWN BY J. RENAUD		DATE 2/13/97			
<small>UNLESS OTHERWISE SPECIFIED DIMENSIONS ARE IN INCHES - TOLERANCES ARE: FRACTIONS DECIMALS ANGLES ±1/64 XX= ±.01 ±1° .XXX=±.005</small>					
THIRD ANGLE PROJECTION 		SIZE B	FSCM NO. 67131	DWG NO 16192	REV 3
DO NOT SCALE DRAWING		SCALE FULL	SHEET 1 OF 1		