

PNP Silicon Darlington Transistors

BSP 60
... BSP 62

- High collector current
- Low collector-emitter saturation voltage
- Complementary types: BSP 50 ... BSP 52 (NPN)

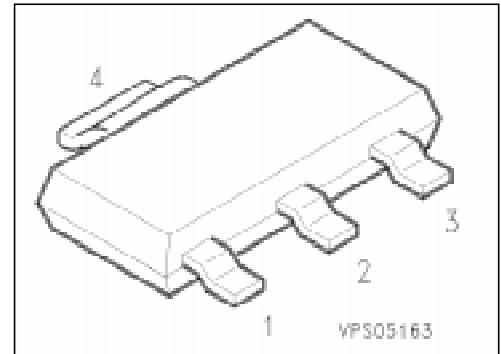

Type	Marking	Ordering Code (tape and reel)	Pin Configuration				Package ¹⁾
			1	2	3	4	
BSP 60	BSP 60	Q62702-P1166	B	C	E	C	SOT-223
BSP 61	BSP 61	Q62702-P1167					
BSP 62	BSP 62	Q62702-P1168					

Maximum Ratings

Parameter	Symbol	Values			Unit
		BSP 60	BSP 61	BSP 62	
Collector-emitter voltage	V_{CEr}	45	60	80	V
Collector-base voltage	V_{CB0}	60	80	90	
Emitter-base voltage	V_{EB0}	5			
Collector current	I_C	1			A
Peak collector current	I_{CM}	2			
Base current	I_B	0.1			
Total power dissipation, $T_s = 124\text{ °C}$	P_{tot}	1.5			W
Junction temperature	T_j	150			°C
Storage temperature range	T_{stg}	- 65 ... + 150			

Thermal Resistance

Junction - ambient ²⁾	$R_{th JA}$	≤ 72	K/W
Junction - soldering point	$R_{th JS}$	≤ 17	

¹⁾ For detailed information see chapter Package Outlines.

²⁾ Package mounted on epoxy pcb 40 mm × 40 mm × 1.5 mm/6 cm² Cu.

Electrical Characteristics

at $T_A = 25\text{ }^\circ\text{C}$, unless otherwise specified.

Parameter	Symbol	Values			Unit
		min.	typ.	max.	

DC characteristics

Collector-emitter breakdown voltage ¹⁾ $I_C = 10\text{ mA}$, $R_{BE} = 150\ \Omega$	$V_{(BR)CER}$	45 60 80	— — —	— — —	V
Collector-base breakdown voltage $I_C = 100\ \mu\text{A}$, $I_B = 0$	$V_{(BR)CB0}$	60 80 90	— — —	— — —	
Emitter-base breakdown voltage $I_E = 100\ \mu\text{A}$, $I_B = 0$	$V_{(BR)EB0}$	5	—	—	
Collector-emitter cutoff current $V_{CE} = V_{CERmax}$, $V_{BE} = 0$	I_{CES}	—	—	10	μA
Emitter-base cutoff current $V_{EB} = 4\text{ V}$, $I_C = 0$	I_{EB0}	—	—	10	
DC current gain ²⁾ $I_C = 150\text{ mA}$, $V_{CE} = 10\text{ V}$ $I_C = 500\text{ mA}$, $V_{CE} = 10\text{ V}$	h_{FE}	1000 2000	— —	— —	—
Collector-emitter saturation voltage ²⁾ $I_C = 500\text{ mA}$, $I_B = 0.5\text{ mA}$ $I_C = 1\text{ A}$, $I_B = 1\text{ mA}$	V_{CEsat}	— —	— —	1.3 1.8	V
Base-emitter saturation voltage ²⁾ $I_C = 500\text{ mA}$, $I_B = 0.5\text{ mA}$ $I_C = 1\text{ A}$, $I_B = 1\text{ mA}$	V_{BEsat}	— —	— —	1.9 2.2	

AC characteristics

Transition frequency $I_C = 100\text{ mA}$, $V_{CE} = 5\text{ V}$, $f = 100\text{ MHz}$	f_T	—	200	—	MHz
Switching times $I_C = 500\text{ mA}$, $I_{B1} = I_{B2} = 0.5\text{ mA}$ (see diagrams)	t_{on} t_{off}	— —	400 1500	— —	ns ns

1) Compare R_{BE} for thermal stability.

2) Pulse test conditions: $t \leq 300\ \mu\text{s}$, $D = 2\%$.

Switching time test circuit

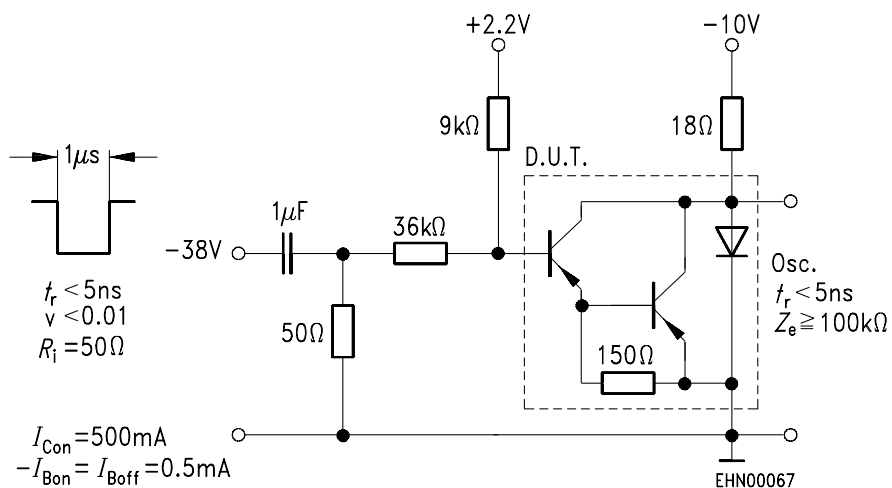

Switching time waveform

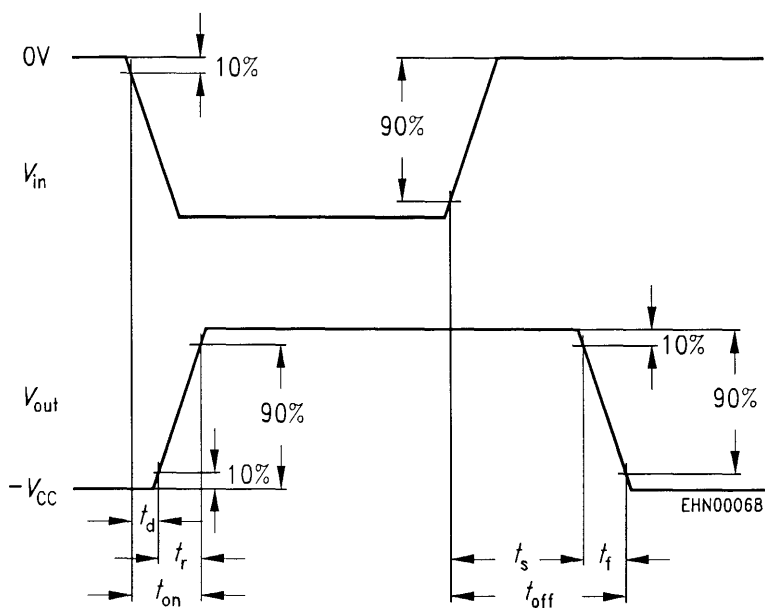

Total power dissipation $P_{tot} = f(T_A^*; T_S)$

* Package mounted on epoxy

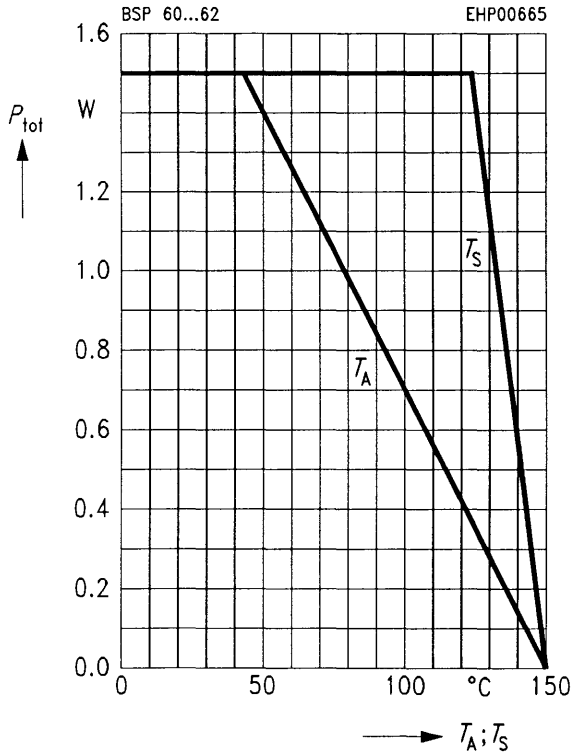

External resistance $R_{BE} = f(T_A)^{**}$

$V_{CB} = V_{CE\ max}$

** $R_{BE\ max}$ for thermal stability

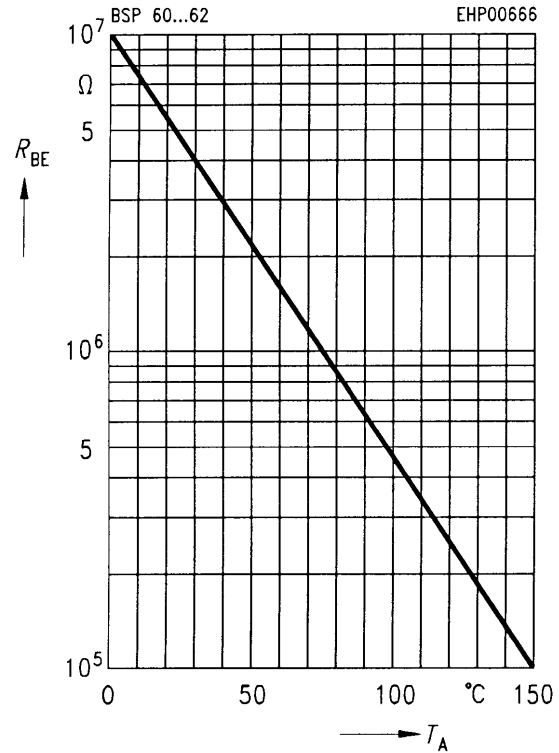

Permissible pulse load $P_{tot\ max} / P_{tot\ DC} = f(t_p)$

DC current gain $h_{FE} = f(I_C)$

$V_{CE} = 10\ V$

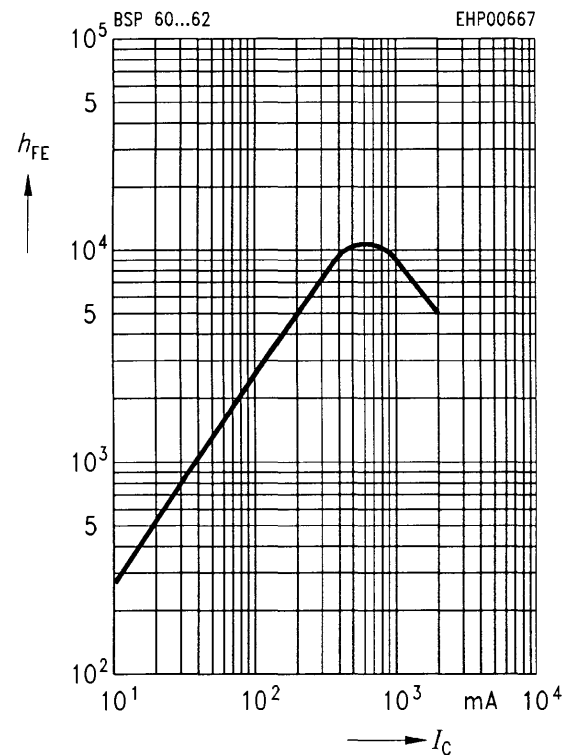
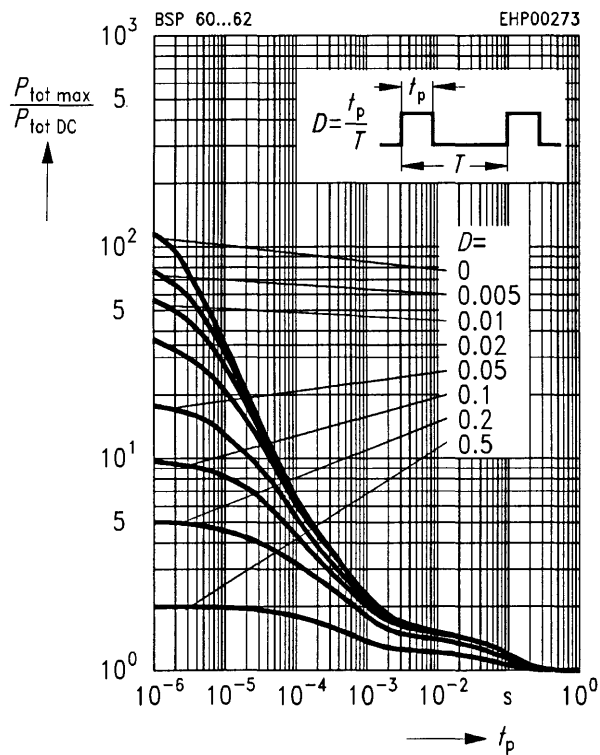

Collector-emitter saturation voltage

$I_C = f(V_{CE\ sat}), I_B\text{-parameter}$

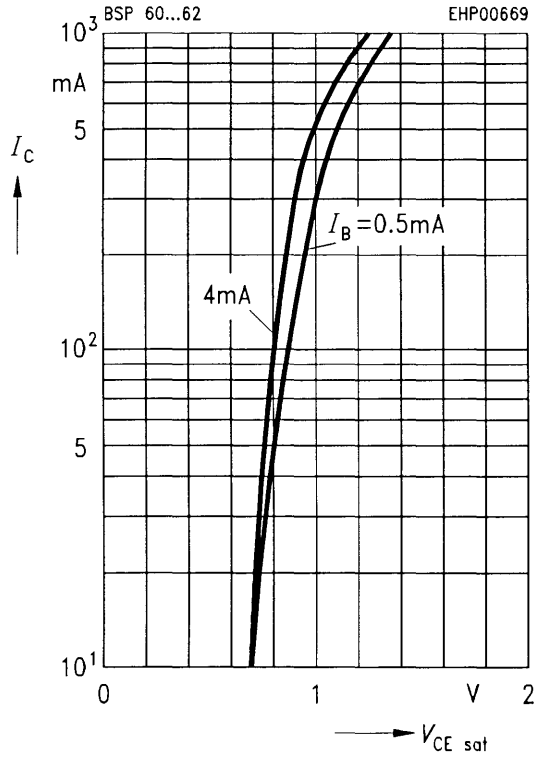

Base-emitter saturation voltage

$I_C = f(V_{BE\ sat}), I_B\text{-parameter}$

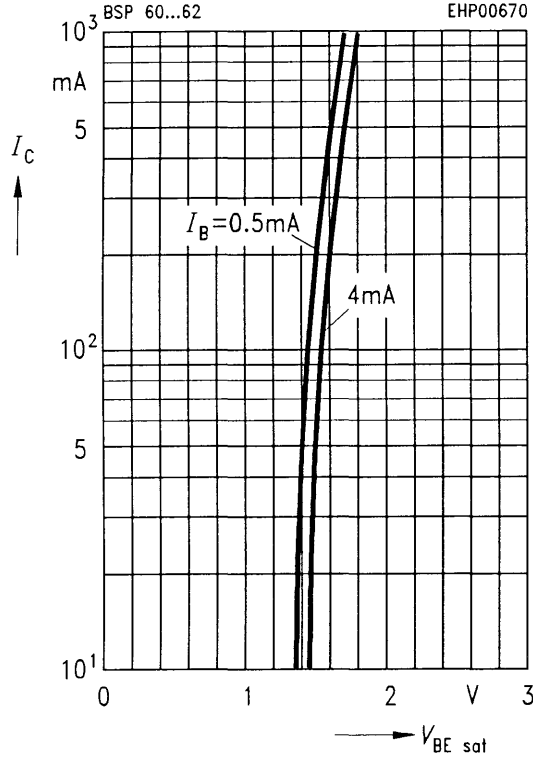

Transition frequency $f_T = f(I_C)$

$V_{CE} = 10\text{ V}, f = 100\text{ MHz}$

