



Devices thru Material Innovation

NEC/TOKIN

Vol.

03

# DC Line Filter

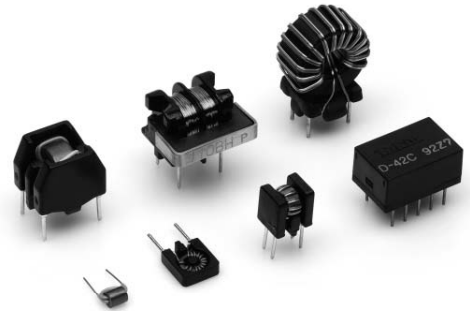

DC LINE FILTER

# Contents

Classification of NEC TOKIN's EMI Suppression parts. ....	3
<b>DIP type</b>	
Common Mode Power Line	
SH Series .....	8
SHO Series .....	10
SBT-03 W Series .....	11
Common Mode Signal Line	
SBT-01 W Series .....	12
Toroidal Cores with Wound cables .....	13
DIP Noise Filters D-03C, 03C1, 05N1, 07C1, 08C2, 08C2A ..	14
DIP Noise Filters D-16C, 20C, 22C .....	16
DIP Noise Filters D-37C, 40C-47C .....	17
DIP Noise Filters D-55C, 58C .....	19
Common Mode (For Telephone Sets)	
Noise Filters for Telephone Sets LFT, HFT, SZ-03 .....	20
Noise Filters for Telephone Sets ST-101, 201, 202, 202S ..	21
Noise Filters for Telephone Sets ST-101A, 201A, 202A .....	22
Noise Filters for Telephone Sets ST-110AV, 110AH, 110BV, 110BH ..	23
Noise Filters for Telephone Sets ST-101F2, 101F4 .....	24
Noise Filters for Telephone Sets ST-104A4, 204A series ..	25
Normal Mode	
SBT Series .....	26
SNT Series .....	27
EMC Filters	
Distributed Constant Filters EK 30, 31, 32 .....	28
Distributed Constant Filters EK 33 .....	30
Feedthrough Capacitor Filters (EG Series) .....	31
EJ Series .....	32
DFD Series .....	33
Tape and Reel Dimensions .....	34
<b>SMD type</b>	
Common Mode Power Line	
SBS-9080 Series .....	36
SBP Series .....	37
DCM Series .....	38
Common Mode Signal Line	
EMC Chip Filters (M-500CT/M-600T Series) .....	40
SCM Series .....	42
Precautions .....	44
Tape and Reel Dimensions .....	45

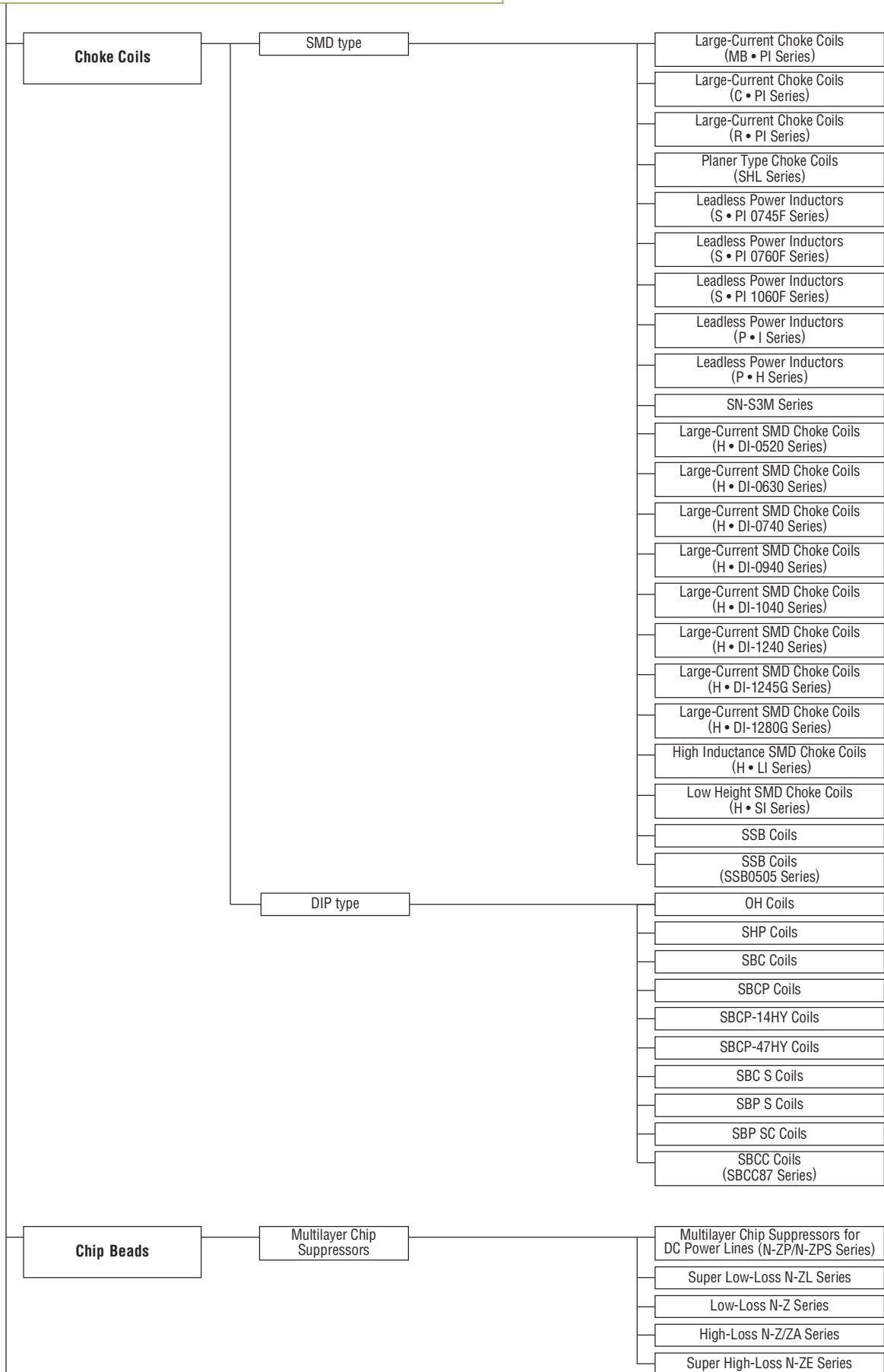

(Continued)

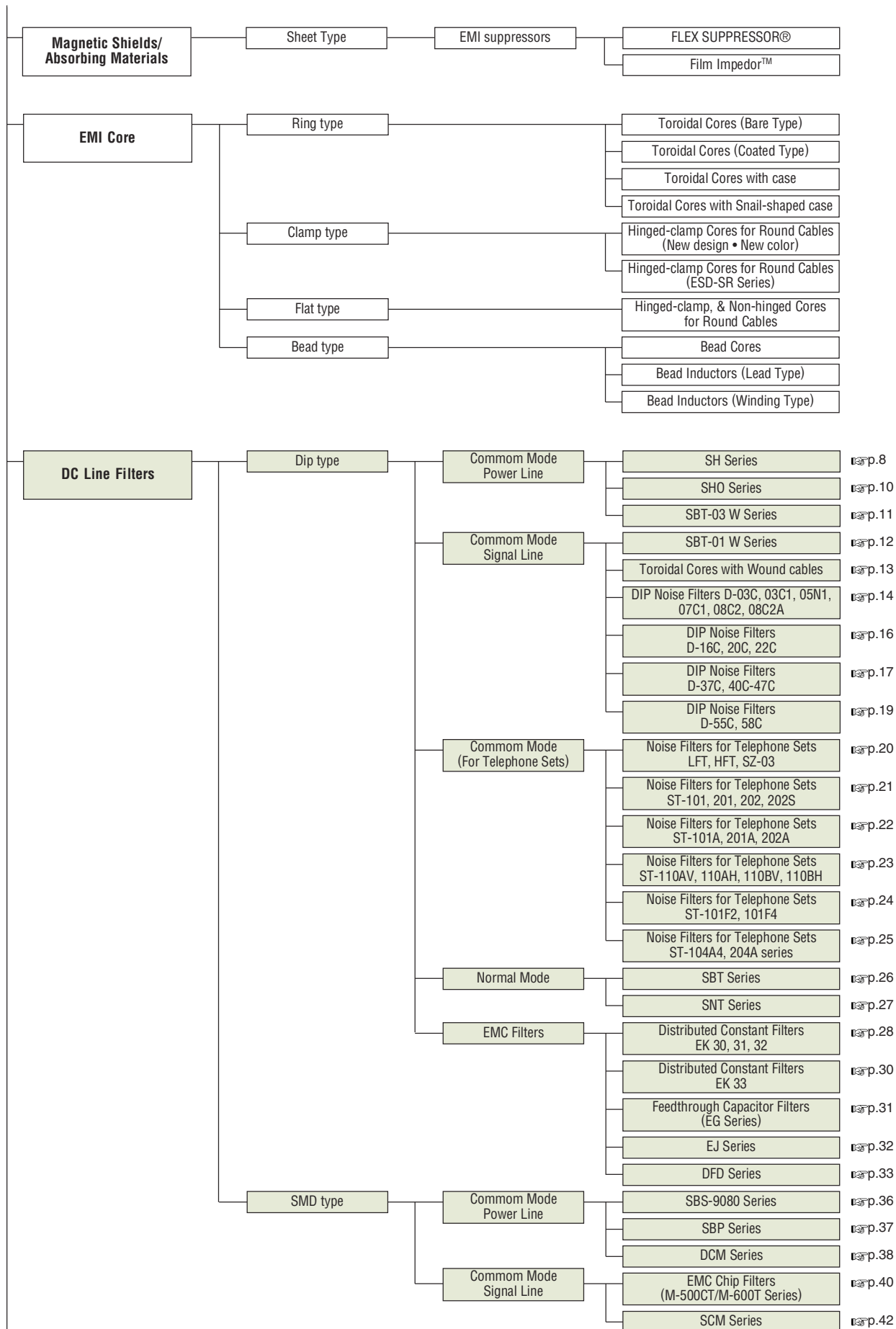

(Continued)

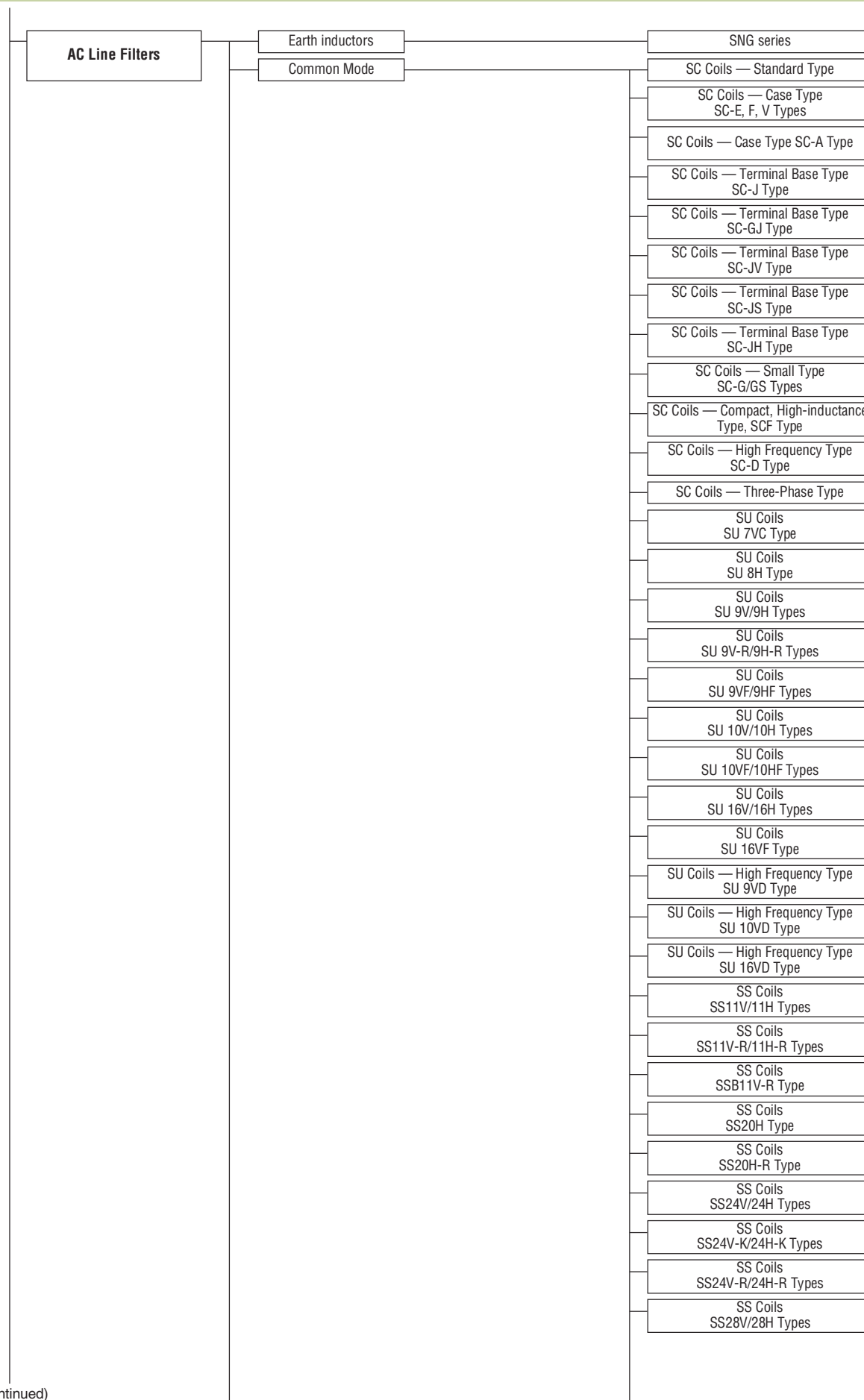

(Continued)

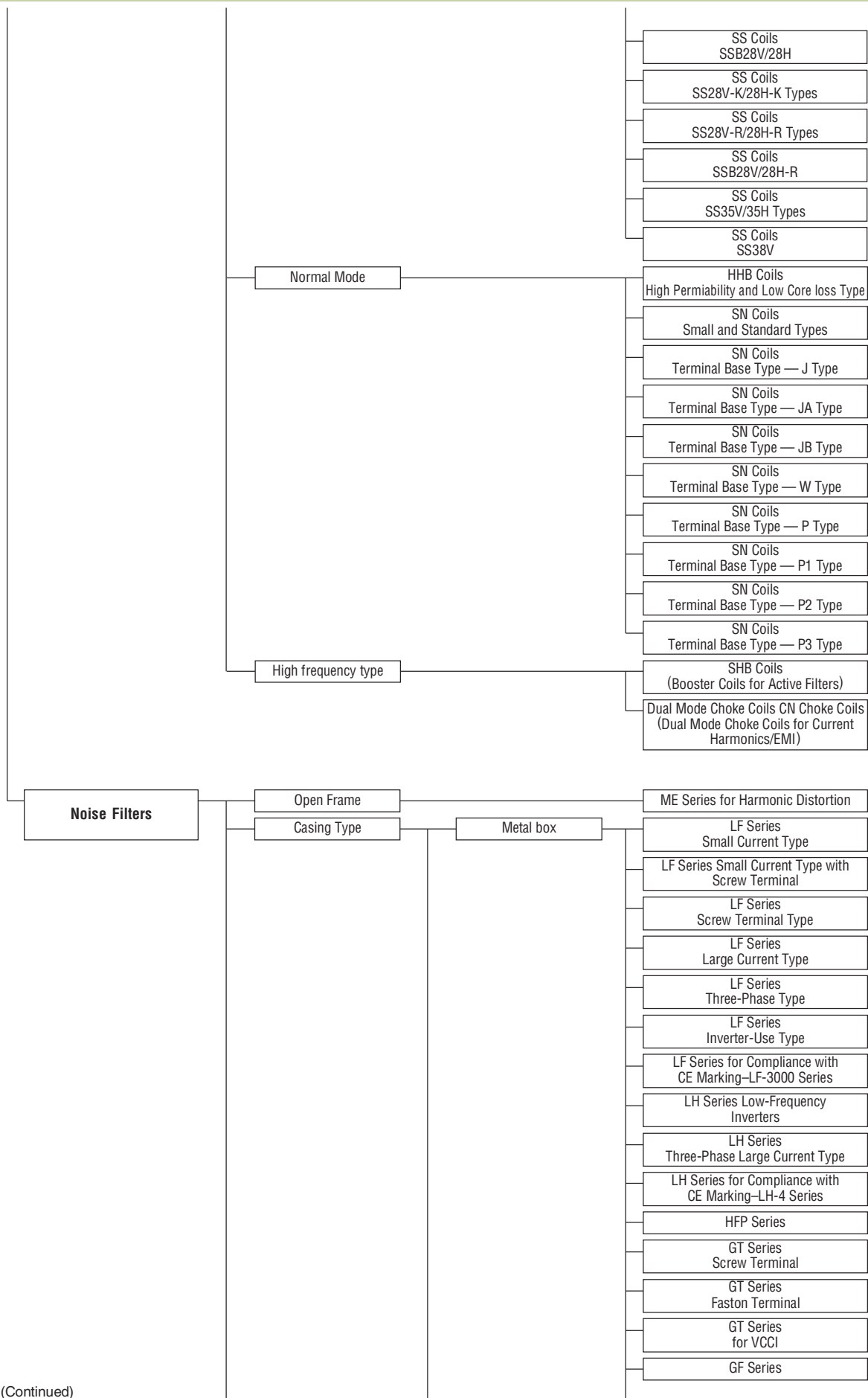

(Continued)

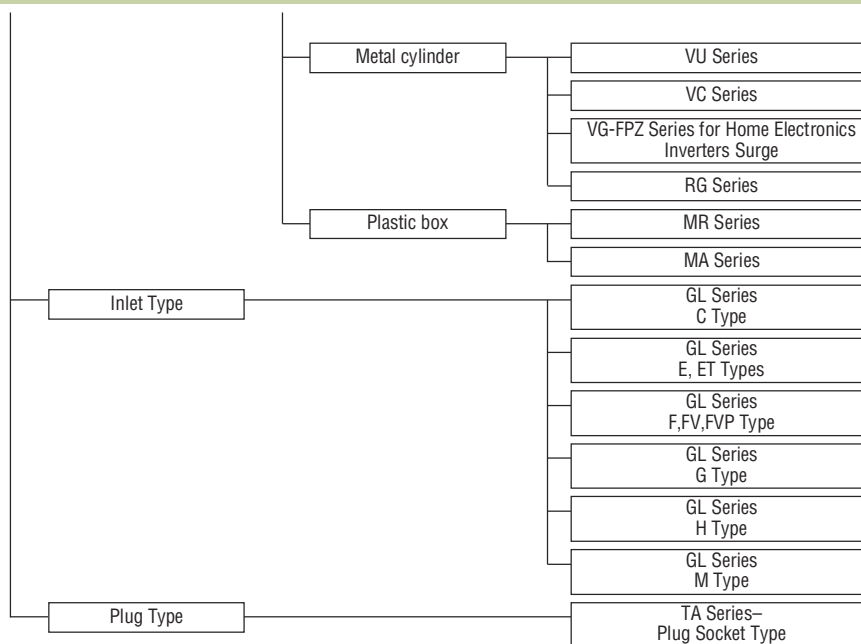

# SH Series

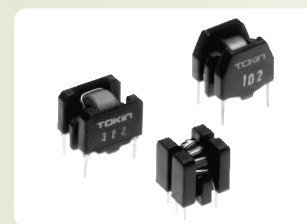

Model	Rated voltage DC (V)	Rated current (A)	Inductance ( $\mu$ H) min.	DC resistance ( $m\Omega$ /line) max.	Operating temperature range ( $^{\circ}$ C)	Shape and dimensions	
<b>SH-101</b>	150	3.0	0.35	16	-25 to +80	Fig. 1	
<b>SH-102</b>	150	3.0	1.5	26	-25 to +80		
<b>SH-201</b>	150	3.0	0.5	16	-25 to +80		
<b>SH-202</b>	150	3.0	1.5	20	-25 to +80		
<b>SH-301</b>	150	3.0	3.2	22	-25 to +80		
<b>SH-302</b>	150	3.0	7.5	26	-25 to +80	Fig. 2	
<b>SH-211</b>	150	3.0	0.5	18	-25 to +80		
<b>SH-212</b>	150	3.0	1.5	23	-25 to +80		
<b>SH-311</b>	150	3.0	3.2	25	-25 to +80		
<b>SH-312</b>	150	3.0	7.5	30	-25 to +80		
for 2 lines	<b>SH-121</b>	50	3.0	0.35	11	-25 to +80	Fig. 3
	<b>SH-122</b>	50	3.0	1.5	20	-25 to +80	
	<b>SH-221</b>	50	3.0	0.5	11	-25 to +80	
	<b>SH-222</b>	50	3.0	1.5	14	-25 to +80	
	<b>SH-321</b>	50	3.0	3.5	14	-25 to +80	
for 2 lines	<b>SH-322</b>	50	3.0	7.5	20	-25 to +80	Fig. 4
	<b>SH-132</b>	50	2.4	2.6	51	-25 to +60	
	<b>SH-432</b>	50	2.4	30.0	51	-25 to +60	
for 3 lines	<b>SH-S132</b>	50	1.0	1.7	81	-25 to +80	Fig. 5



Shape and Dimensions/Circuit Diagram

●Fig. 1

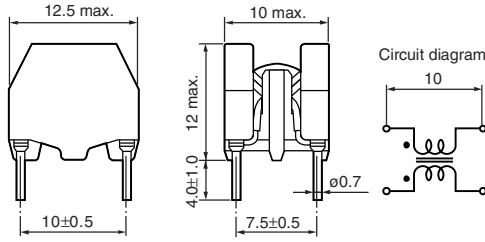

●Fig. 2

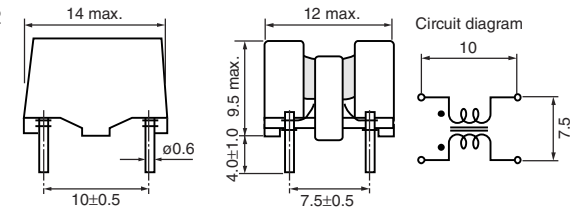

●Fig. 3

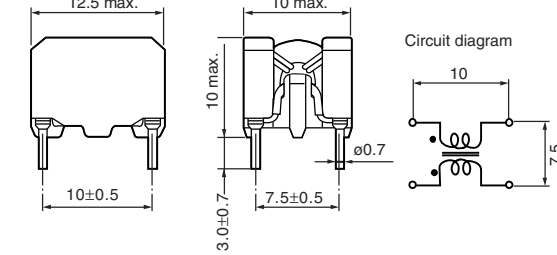

●Fig.4

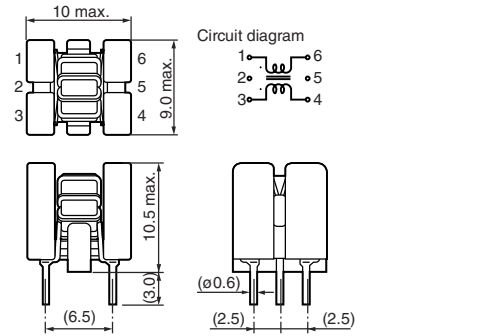

●Fig.5

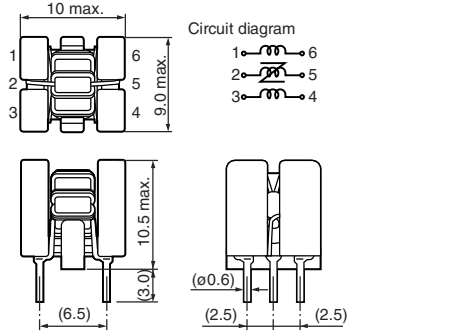

[mm]

Impedance vs. Frequency

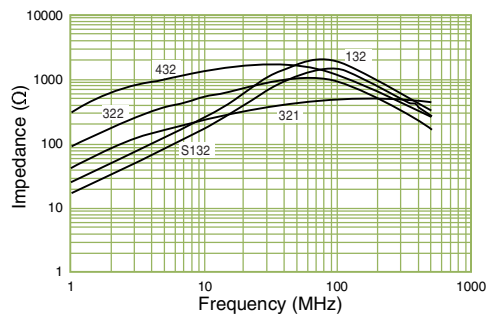
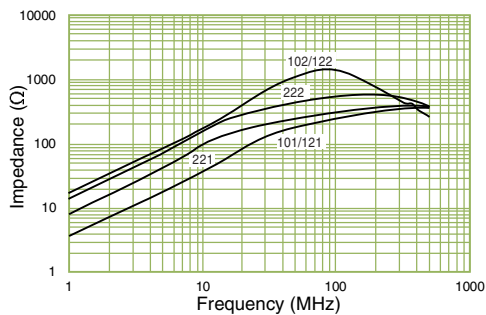
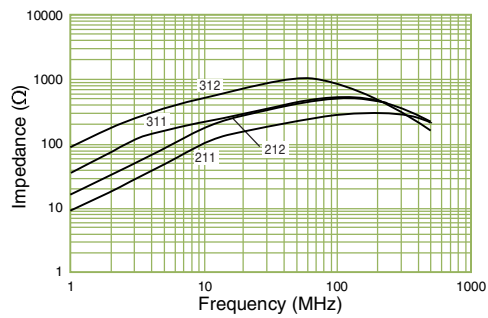
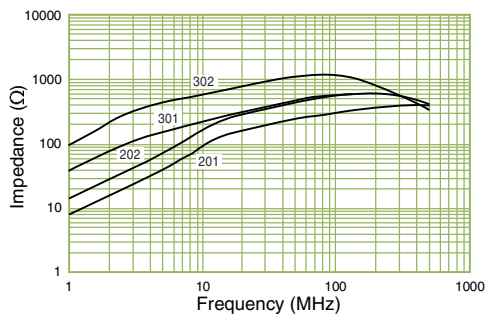

# SHO Series



Model	Rated voltage DC (V)	Rated current (A)	Inductance (μH) min.	DC resistance (mΩ/line) max.	Operating temperature range (°C)
SHO-101	50	4.0	2.0	15.5	-25 to +70
SHO-102	50	4.0	0.6	10.0	-25 to +70
SHO-201	50	4.0	5.0	15.5	-25 to +70
SHO-202	50	4.0	1.6	10.0	-25 to +70
SHO-301	50	4.0	12.0	15.5	-25 to +70
SHO-302	50	4.0	3.9	10.0	-25 to +70

### Shape and Dimensions

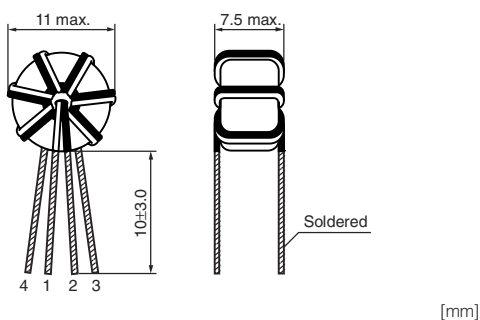

### Circuit Diagram

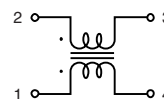

### Impedance vs. Frequency

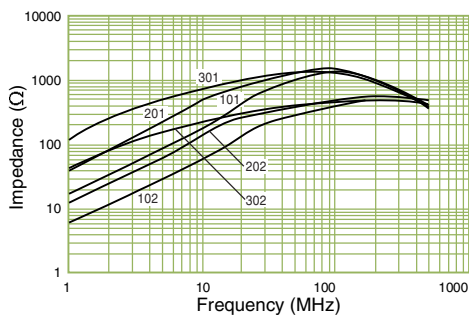

# SBT-03W Series



Model	Rated voltage DC (V)	Rated current (A)	Inductance (100kHz, 1mA) ( $\mu$ H) min.	DC resistance ( $m\Omega$ ) max.	Operating temperature range ( $^{\circ}$ C)	Wire size (mm $\phi$ )	Packaging
<b>SBT-0308W</b>	50	3.0	6.75	20	-25 to +85	0.4	Bulk (100 pcs.)
<b>SBT-0310W</b>	50	2.5	7.7	30	-25 to +80	0.35	
<b>SBT-0315W</b>	50	2.0	11.9	45	-25 to +75	0.3	

- Withstanding voltage: 200VDC (one minute, between lines)
- Insulation resistance: more than 10M $\Omega$  (100VDC, between lines)

### Shape and Dimensions

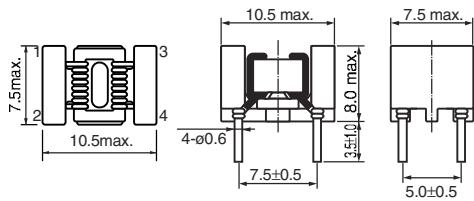

[mm]

### Circuit Diagram

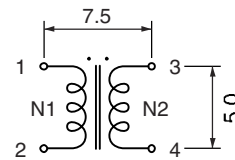

[mm]

### Impedance vs. Frequency

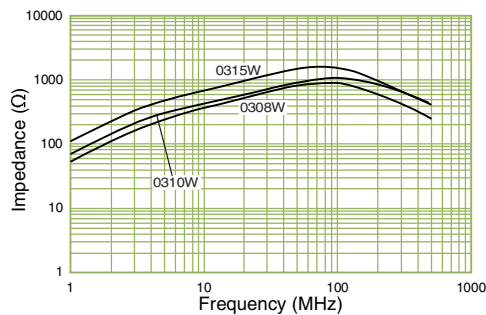

# SBT-01W Series



Model	Rated voltage DC (V)	Rated current (mA)	Inductance (1kHz, 70mA) (μH)	DC resistance (mΩ) max.	Operating temperature range (°C)	Packaging
<b>SBT-0115W</b>	50	500	≧5	30	-25 to +70	Bulk (100pcs.)
<b>SBT-0140W</b>	50	500	40±35%	40	-25 to +70	
<b>SBT-0160W</b>	50	500	60±35%	45	-25 to +70	
<b>SBT-0180W</b>	50	500	80±35%	55	-25 to +70	

• Withstanding voltage: 200VDC (one minute, between lines) • Insulation resistance: more than 10MΩ (100VDC, between lines)

### Shape and Dimensions

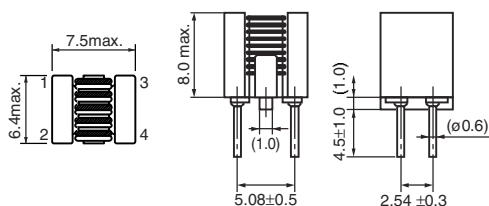

[mm]

### Circuit Diagram

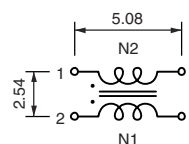

[mm]

### Impedance vs. Frequency

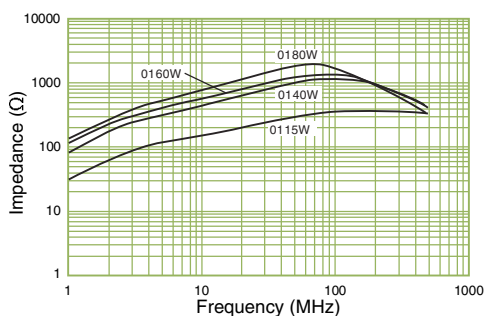

# Troidal Cores with Wound Cables



Model	Core	Dimensions (mm)				No. of turns	Wire	Winding status	Frequency range (MHz)
		A	B	C	D				
<b>ESD-H-12E</b>	ESD-R-12C	16	20	5	25	7	UL1007 AWG26 (ø0.4)	Bi-filar winding	Up to 300
<b>ESD-H-12M</b>	ESD-R-12A	15	18.5	5	15	9	Teflon wire (ø0.4)	Bi-filar winding	Up to 100
<b>ESD-H-14U</b>	ESD-R-14A	17.5	7	5	15	10	UL1609 AWG26 (ø0.4)	Bi-filar winding	Up to 100
<b>ESD-H-14NU</b>	ESD-R-14C2	17.5	7	5	15	10	UL1609 AWG26 (ø0.4)	Bi-filar winding	Up to 300

• Recommended soldering conditions: 350±10°C, 2 to 3 sec.

## Shape and Dimensions

● ESD-H Series

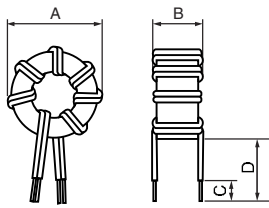

## Circuit Diagram

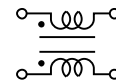

## Impedance vs. Frequency

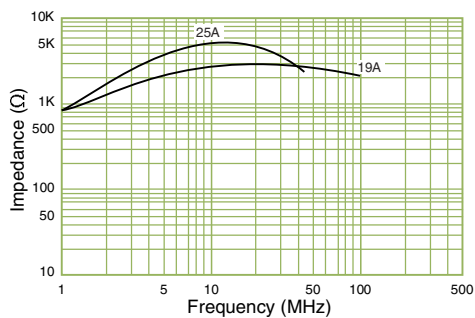
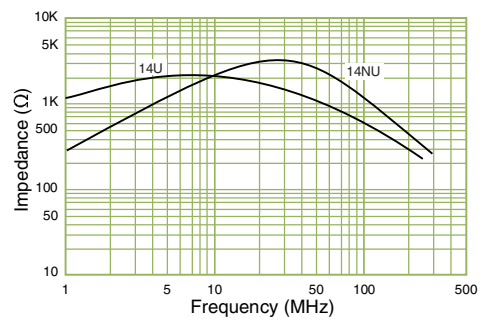
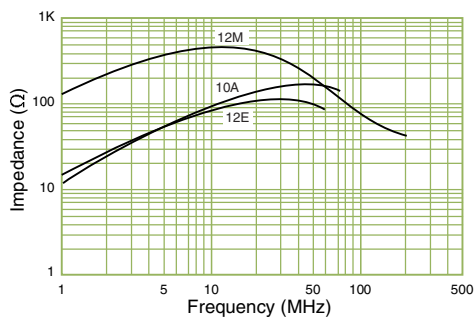

# DIP Noise Filters

## D-03C, 03C1, 05N1, 07C1, 08C2, 08C2A

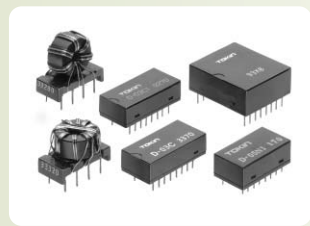

Model	Circuit diagram	Number of terminals/Circuits	Rated voltage DC (V)	Rated current DC (mA/Line)	DC resistance (mΩ/Line) max.	Operating temperature range (°C)
<b>D-03C</b>		4 cores	50	150	75	-20 to +70
<b>D-03C1</b>				100	150	-20 to +70
<b>D-05N1</b>		8 cores	50	100	10	-20 to +70
<b>D-07C1</b>		1 core	50	300	100	-20 to +70
<b>D-08C2</b>		1 core	50	2300	25	-20 to +70
<b>D-08C2A</b>		1 core	50	500	70	-20 to +70

• Withstanding voltage: 200VDC (one minute, between lines) • Insulation resistance: more than 10MΩ (100VDC, between lines)

### Shape and Dimensions

●D-03C, 03C1

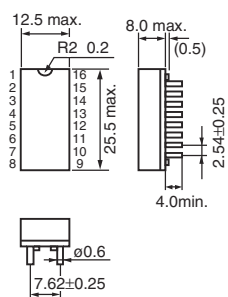

●D-05N1

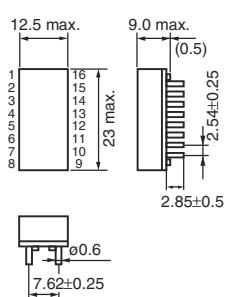

●D-07C1

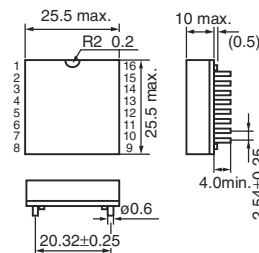

●D-08C2

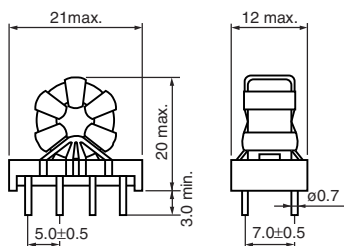

●D-08C2A

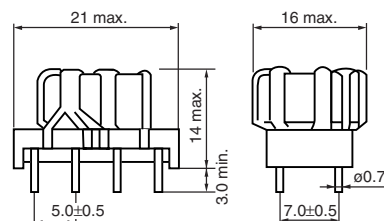

[mm]

Impedance vs. Frequency

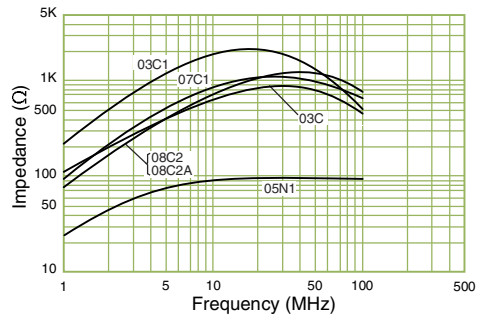

# DIP Noise Filters

## D-16C, 20C, 22C

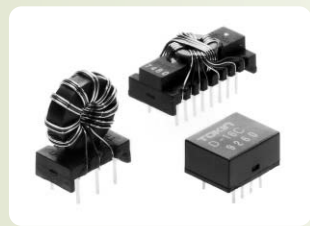

Model	Circuit diagram	Number of terminals/ Circuits	Rated voltage DC (V)	Rated current DC (mA/Line)	DC resistance (mΩ/Line) max.	Operating temperature range (°C)
D-16C		1 core 8P/4 circuits Common mode	50	100	50	-20 to +70
D-20C		1 core 16P/8 circuits Common mode	50	500	40	-20 to +70
D-22C		1 core 6P/3 circuits Common mode	50	1500	40	-20 to +70

• Withstanding voltage: 200VDC (one minute, between lines) • Insulation resistance: more than 10MΩ (100VDC, between lines)

### Shape and Dimensions

●D-16C

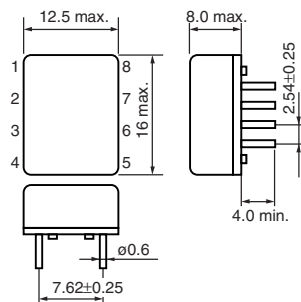

●D-20C

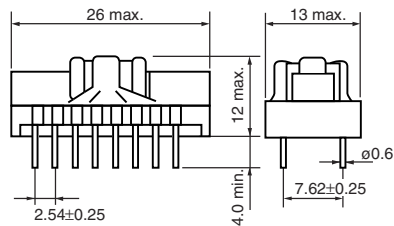

●D-22C

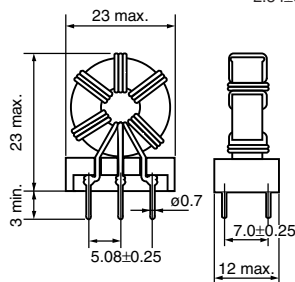

[mm]

### Impedance vs. Frequency

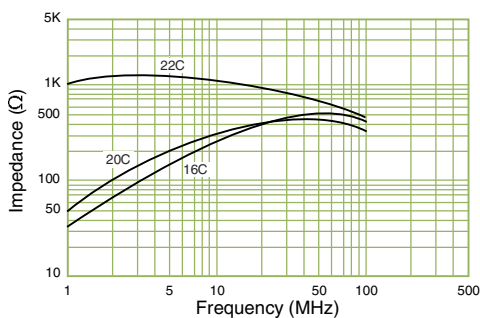



# DIP Noise Filters

## D-37C, 40C, 42C, 45C, 47C

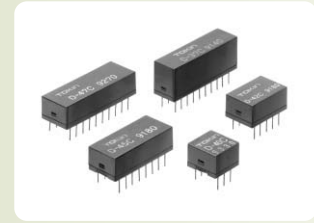

Model	Circuit diagram	Number of terminals/ Circuits	Rated voltage DC (V)	Rated current DC (mA/Line)	DC resistance (mΩ/Line) max.	Operating temperature range (°C)
D-37C		1 core 20P/10 circuits Common mode	50	300	200	-20 to +70
D-40C		1 core 6P/3 circuits Common mode	50	300	200	-20 to +70
D-42C		1 core 10P/5 circuits Common mode	50	300	200	-20 to +70
D-45C		1 core 16P/8 circuits Common mode	50	300	150	-20 to +70
D-47C		1 core 20P/10 circuits Common mode	50	300	200	-20 to +70

• Withstanding voltage: 200VDC (one minute, between lines) • Insulation resistance: more than 10MΩ (100VDC, between lines)

### Shape and Dimensions

●D-37C

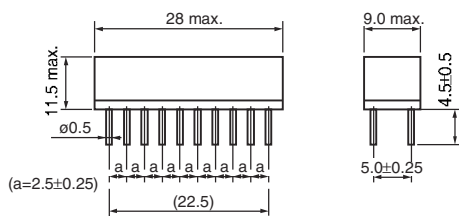

●D-40C, 42C, 45C, 47C

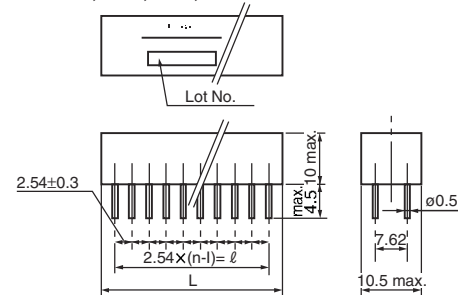

Model	Number of Circuits	ℓ	L
D-40C	3	5.08	12.7 max.
D-42C	5	10.16	18 max.
D-45C	8	17.78	25 max.
D-47C	10	22.86	28 max.

[mm]

Impedance vs. Frequency

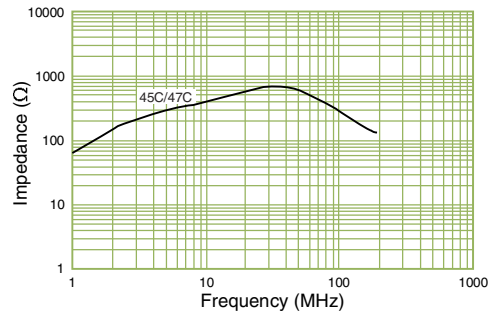
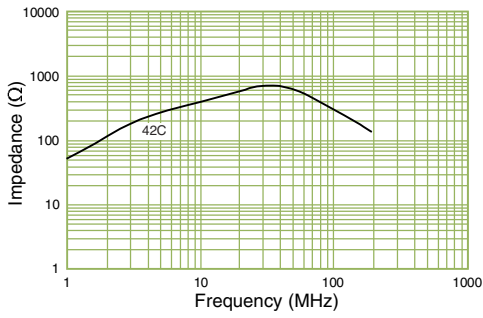
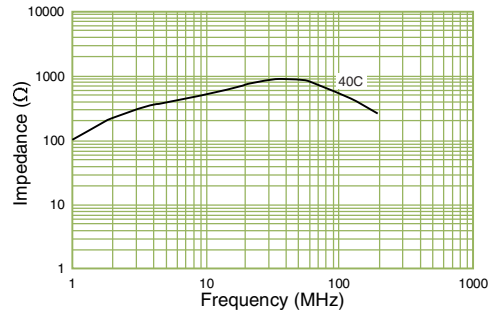
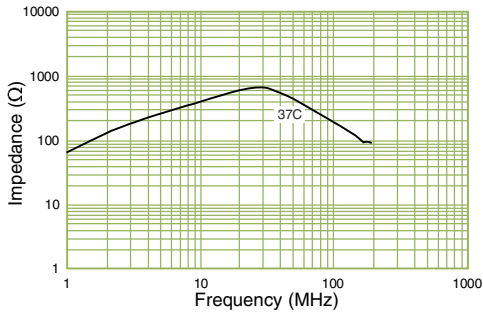

# DIP Noise Filters

## D-55C, 58C

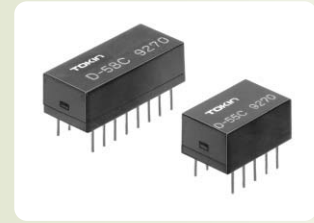

Model	Circuit diagram	Number of terminal/ Circuits	Rated voltage DC (V)	Rated current DC (mA/Line)	DC resistance (mΩ/Line) max.	Operating temperature range (°C)
D-55C		1 core 10P/5 circuits Common mode	50	300	200	-20 to +70
D-58C		1 core 16P/8 circuits Common mode	50	300	200	-20 to +70

- Withstanding voltage: 200VDC (one minute, between lines)
- Insulation resistance: more than 10MΩ (100VDC, between lines)

### Shape and Dimensions

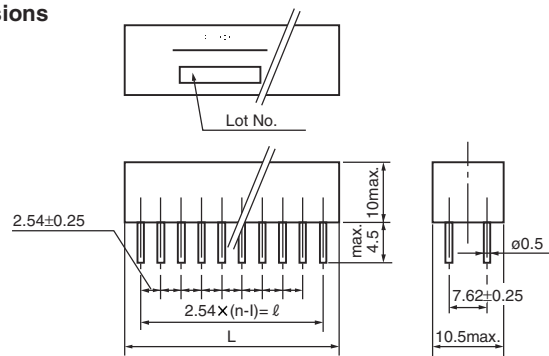

Model	Number of Circuits	ℓ	L
D-55C	5	10.16	18 max.
D-58C	8	17.78	25 max.

[mm]

### Impedance vs. Frequency

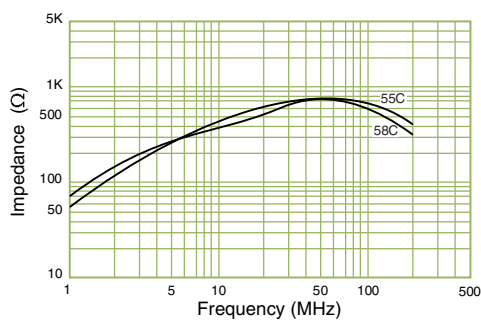

# EMI/EMC Filters for Telephone Sets

## LFT, HFT, SZ-03



Model	Frequency range (MHz)	Impedance or attenuation (kΩ) min.	Rated voltage DC (V)	Rated current (mA)	DC resistance (Ω/line) max.	Operating temperature range (°C)	Remarks
LFT	0.5 to 7	27 (15 dB) (at 0.5 MHz)	50	100	10	-20 to +75	AM band
SZ-03	0.5 to 7	27 (at 0.5 MHz)	50	100	10	-20 to +75	AM band
HFT	7 to 40	2.6 (15 dB) (at 7MHz)	50	100	0.2	-20 to +75	FM band

• Withstanding voltage: 500VDC (one minute, between lines) • Insulation resistance: more than 10MΩ (250VDC, between lines)

### Shape and Dimensions/Circuit Diagram

●LFT

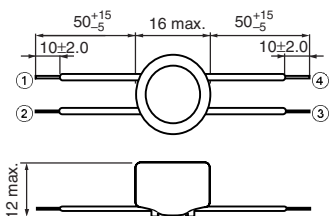

●HFT

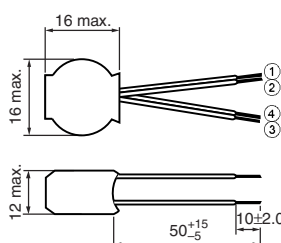

●SZ-03

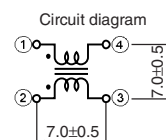
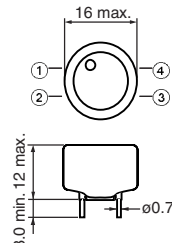

[mm]

### Installation Examples

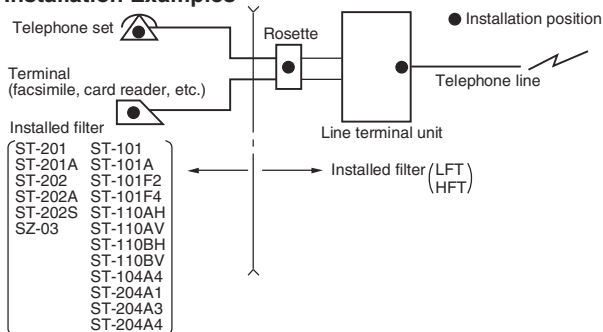

### Design Examples

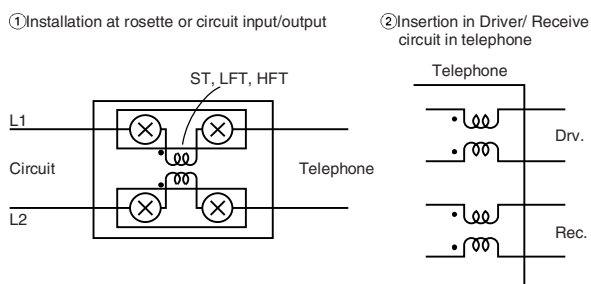

### Impedance vs. Frequency

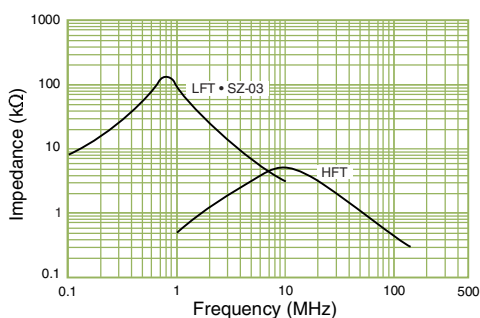

# EMI/EMC Filters for Telephone Sets

## ST-101, 201, 202, 202S



Model	Frequency range (MHz)	Impedance (kΩ) min.	Rated voltage DC (V)	Rated current (mA)	DC resistance (mΩ/Line) max.	Operating temperature range (°C)	Remarks
ST-101	0.5 to 7	3 (at 0.5 MHz)	50	200	180	-20 to +75	AM band
ST-201	7 to 40	1.5 (at 7 MHz)	50	200	100	-20 to +75	FM band
ST-202	7 to 100	0.6 (at 100 MHz)	50	1000	40	-20 to +75	FM band
ST-202S	7 to 100	0.6 (at 100 MHz)	50	1000	35	-20 to +75	FM band

- Withstanding voltage: 500VDC (one minute, between lines)
- Insulation resistance: more than 10MΩ (250VDC, between lines)
- Recommended soldering conditions: 350±10°C, 2 to 3 sec.

### Shape and Dimensions/Circuit Diagram

#### ● ST-101, 201

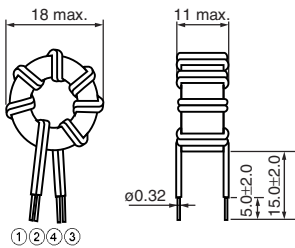

#### ● ST-202

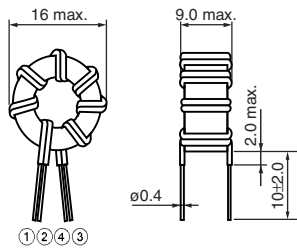

#### ● ST-202S

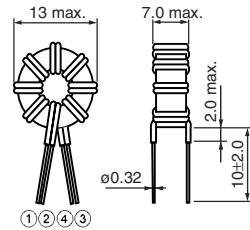

Circuit diagram

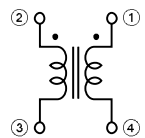

[mm]

### Installation Examples

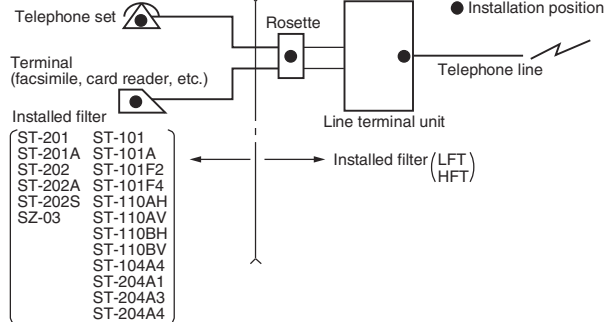

### Design Examples

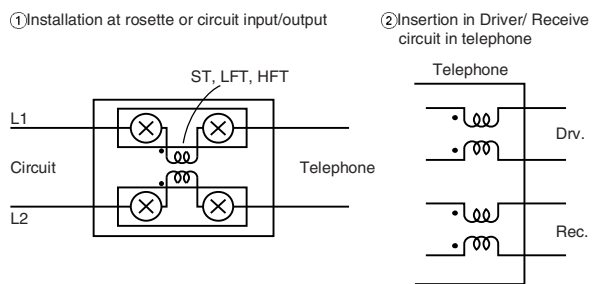

### Impedance vs. Frequency

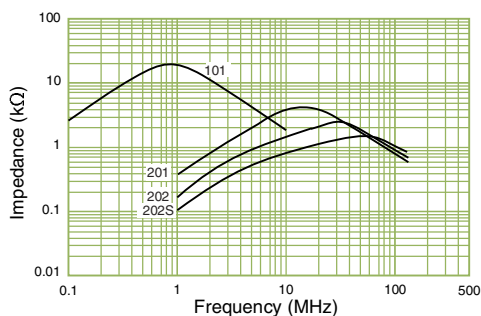

# EMI/EMC Filters for Telephone Sets

## ST-101A, 201A, 202A



Model	Frequency range (MHz)	Impedance (kΩ) min.	Rated voltage DC (V)	Rated current (mA)	DC resistance (mΩ/Line) max.	Operating temperature range (°C)	Remarks
ST-101A	0.5 to 7	3 (at 0.5 MHz)	50	200	250	-20 to +65	AM band
ST-201A	7 to 40	1.5 (at 7 MHz)	50	200	150	-20 to +65	FM band
ST-202A	7 to 100	0.6 (at 100 MHz)	50	1000	50	-20 to +65	FM band

• Withstanding voltage: 500VDC (one minute, between lines) • Insulation resistance: more than 10MΩ (100VDC, between lines)

### Shape and Dimensions/Circuit Diagram

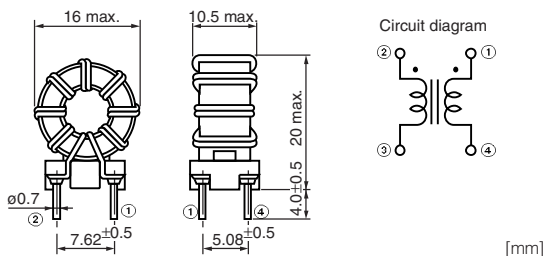

### Installation Examples

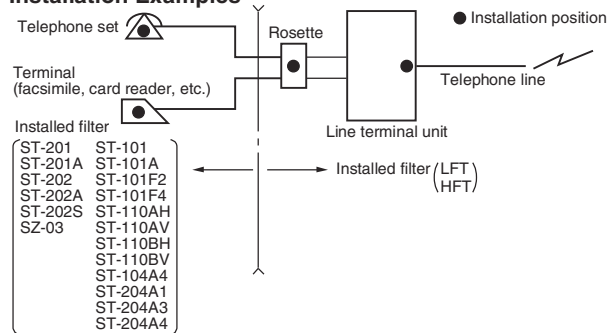

### Design Examples

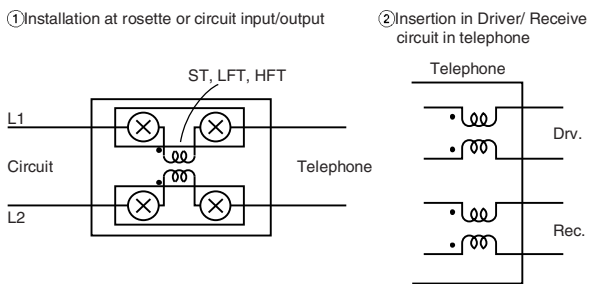

### Impedance vs. Frequency

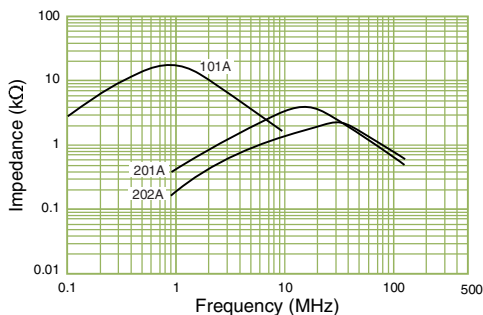

# EMI/EMC Filters for Telephone Sets

## ST-110AV, 110AH, 110BV, 110BH

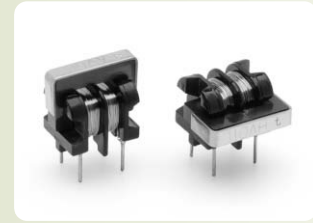

Model	Frequency range (MHz)	Impedance (kΩ) min.	Rated voltage DC (V)	Rated current (mA)	DC resistance (mΩ/Line) max.	Operatings temperature range (°C)	Remarks
ST-110AV	0.5 to 7	27 (at 0.5 MHz)	50	300	3	-20 to +75	AM band
ST-110AH	0.5 to 7	27 (at 0.5 MHz)	50	300	3	-20 to +75	AM band
ST-110BV	0.5 to 7	150 (Resonant)	50	150	7.5	-20 to +75	AM band
ST-110BH	0.5 to 7	150 (Resonant)	50	150	7.5	-20 to +75	AM band

• Withstanding voltage: 500VDC (one minute, between lines) • Insulation resistance: more than 10MΩ (250VDC, between lines)

### Shape and Dimensions/Circuit Diagram

● ST-110AV, ST-110BV

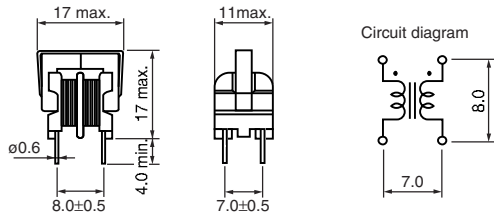

● ST-110AH, ST-110BH

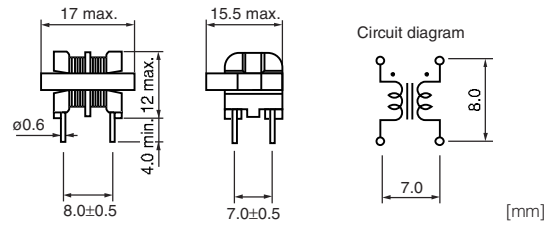

### Installation Examples

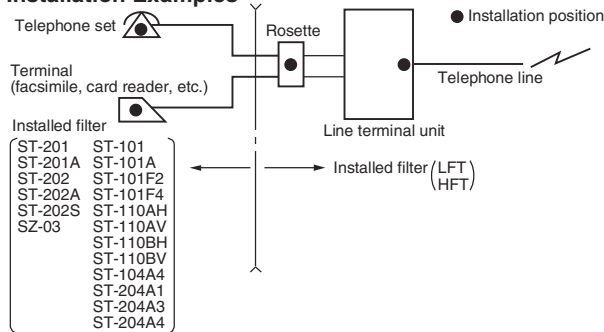

### Design Examples

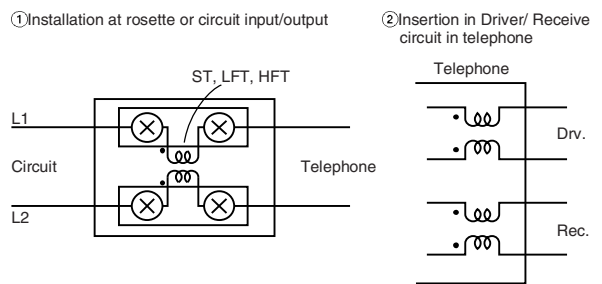

### Impedance vs. Frequency

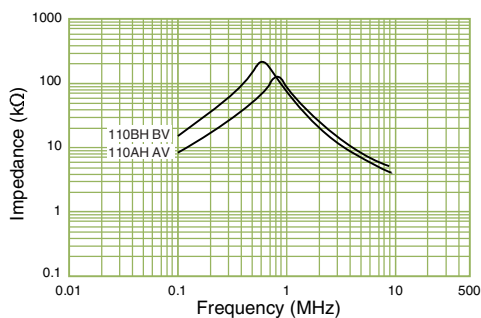

# EMI/EMC Filters for Telephone Sets

## ST-101F2, 101F4



Model	Frequency range (MHz)	Impedance (kΩ) min.	Rated voltage DC (V)	Rated current (mA)	DC resistance (Ω/Line) max.	Operating temperature range (°C)	Remarks
ST-101F2	0.5 to 7	40 (at 600 kHz)	50	200	2.7	-20 to +75	AM band
ST-101F4	0.5 to 7	60 (at 600 kHz)	50	200	3.5	-20 to +75	AM band

• Withstanding voltage: 500VDC (one minute, between lines) • Insulation resistance: more than 10MΩ (250VDC between lines)

### Shape and Dimensions/Circuit Diagram

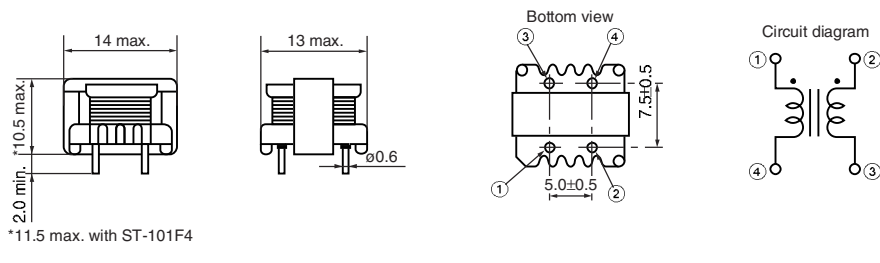

[mm]

### Installation Examples

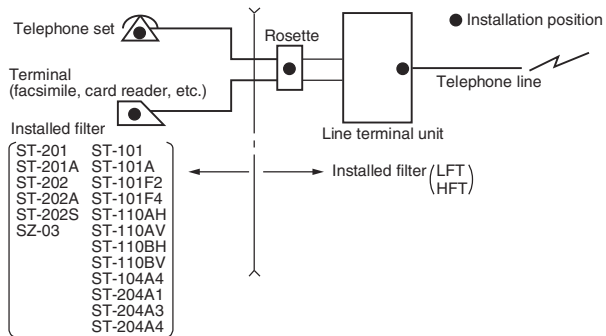

### Design Examples

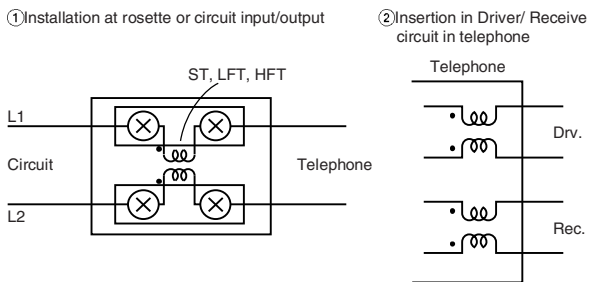

### Impedance vs. Frequency

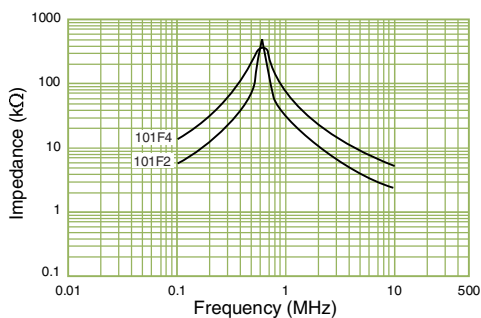



# EMI/EMC Filters for Telephone Sets

## ST-104A4, 204A Series



Model	Frequency range (MHz)	Impedance (kΩ) min.	Rated voltage DC (V)	Rated current (mA)	DC resistance (Ω/Line) max.	Operating temperature range (°C)	Remarks
ST-104A4	0.5 to 7	3.0 (at 0.5 MHz)	50	500	0.36	-20 to +75	AM band
ST-204A1	7 to 100	0.25 (at 10 MHz)	50	500	0.10	-20 to +75	FM band
ST-204A3	7 to 40	1.0 (at 7 MHz)	50	500	0.17	-20 to +75	FM band
ST-204A4	7 to 40	0.6 (at 7 MHz) REF	50	500	0.12	-20 to +75	FM band

- Withstanding voltage: 500VDC (one minute, between lines)
- Insulation resistance: more than 10MΩ (250VDC, between lines)

### Shape and Dimensions/Circuit Diagram

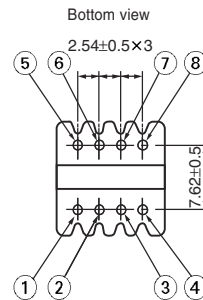
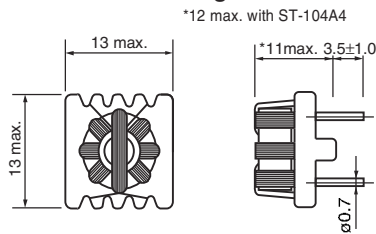

Circuit diagram

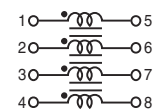

[mm]

### Installation Examples

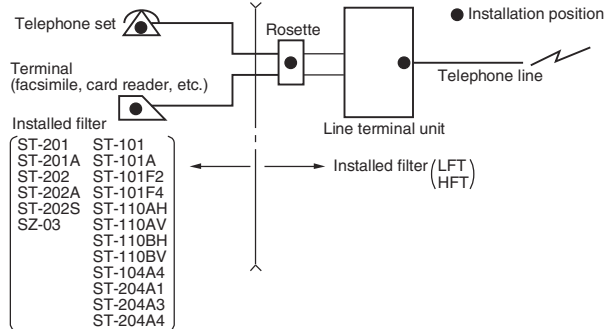

### Design Examples

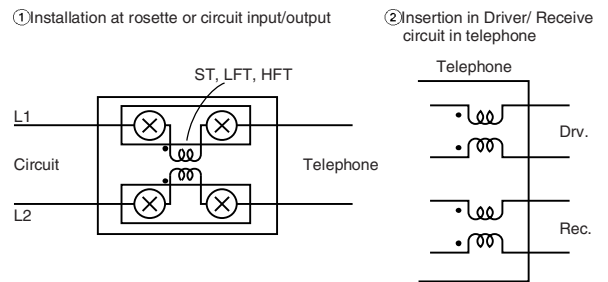

### Impedance vs. Frequency

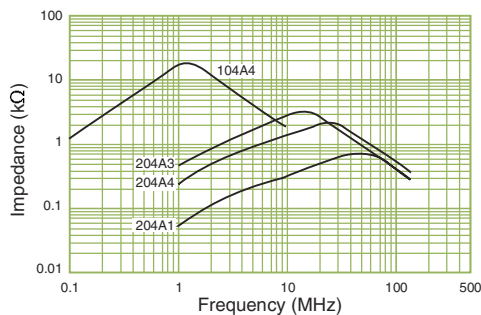

# SBT Series



• Tape and Reel Dimensions (see page 34)

Model	Rated voltage DC (V)	Rated current (mA)	Inductance (1kHz, 70mA) (μH)	DC resistance (mΩ) max.	Operating temperature range (°C)	Packaging
SBT-0208□	50	500	8±50%	20	-25 to +70	Bulk (100pcs.)
SBT-0210□	50	500	10±50%	20	-25 to +70	
SBT-0240□	50	500	40±35%	34	-25 to +70	
SBT-0260□	50	500	60±35%	50	-25 to +70	

• □ Taping (2000 pcs./ reel x 6), ▢ Flat taping (1000pcs./ box x 10)

## Shape and Dimensions

● SBT-02□□

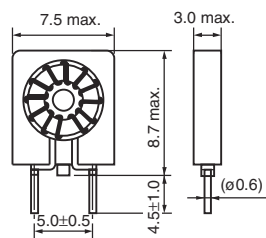

[mm]

## Impedance vs. Frequency

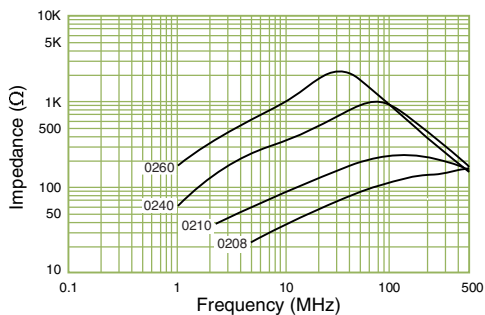

# SNT Series



• Tape and Reel Dimensions (see page 34)

Model	Rated current* (A)	Inductance (μH) min.	DC resistance (mΩ) max.	Operating temperature range (°C)	Packaging
SNT-S10□□	3.0	1.5	25	-20 to +60	Bulk (100 pcs.)
SNT-S20□□	1.5	6	35	-20 to +60	
SNT-S30□□	0.5	13	95	-20 to +60	
SNT-D10□□	3.0	2.5	25	-20 to +60	
SNT-D20□□	1.5	10	45	-20 to +60	
SNT-D30□□	0.5	20	98	-20 to +60	

\*The rated current is for the wire and it is different from the inductance guaranteeing values.

• □□ Taping (1000 pcs./ reel) • □ Flat taping (SNT-S type: 1000 pcs./ reel), (SNT-D type: 500 pcs./ reel)

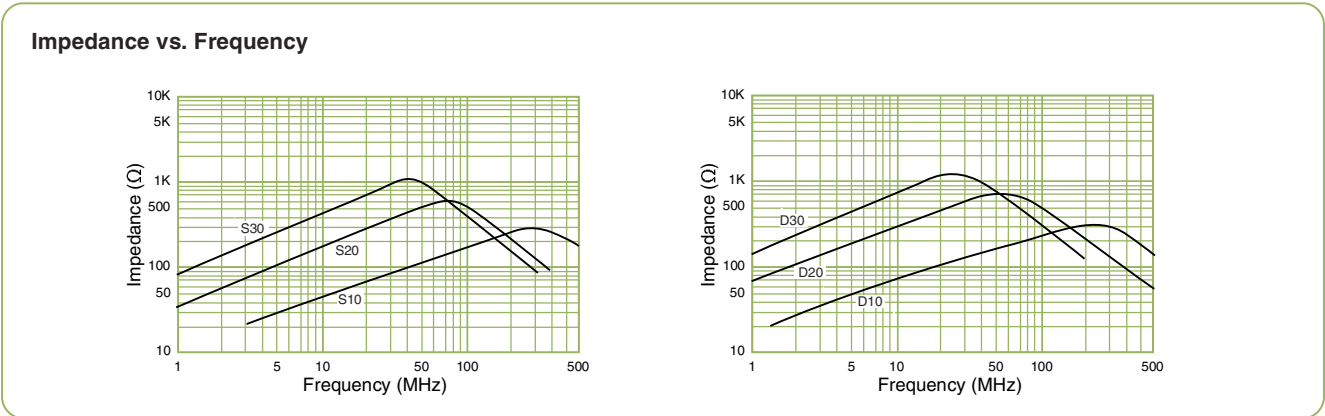
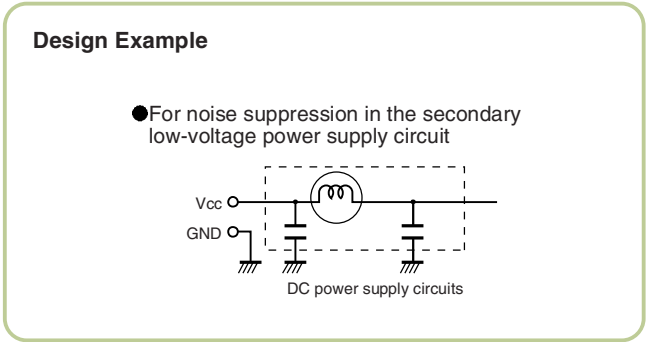
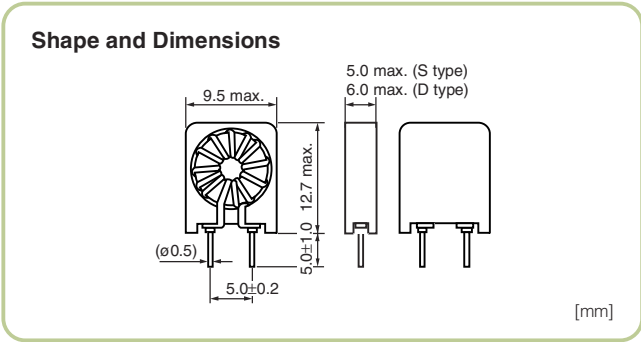

# Distributed Constant Filters

## EK 30, 31, 32

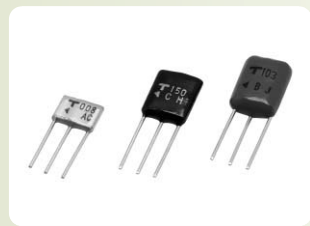

• Tape and Reel Dimensions (see page 34)

	Model	Rated voltage DC (V)	Rated current DC (mA)	DC resistance (mΩ) max.	Dielectric breakdown voltage DC (V)	Insulation resistance (MΩ) min.	Operating temperature range (°C)
Low Frequency Type 30	<b>EK30-1103</b>	50	500	105	125	2×10 <sup>4</sup>	-25 to +85
	<b>EK31-050M</b>	50	500	60	125	2×10 <sup>4</sup>	-25 to +85
	<b>EK31-020M</b>	50	500	60	125	2×10 <sup>4</sup>	-25 to +85
Low Frequency Type 31	<b>EK31-010M</b>	50	500	60	125	2×10 <sup>4</sup>	-25 to +85
	<b>EK31-008M</b>	50	500	60	125	2×10 <sup>4</sup>	-25 to +85
	<b>EK31-004M</b>	50	500	70	125	2×10 <sup>4</sup>	-25 to +85
	<b>EK31-002M</b>	50	500	110	125	2×10 <sup>4</sup>	-25 to +85
	<b>EK31-001M</b>	50	500	150	125	2×10 <sup>4</sup>	-25 to +85
Low Frequency Type 32	<b>EK32-200M</b>	50	500	60	125	2×10 <sup>4</sup>	-25 to +85
	<b>EK32-150M</b>	50	500	60	125	2×10 <sup>4</sup>	-25 to +85
	<b>EK32-100M</b>	50	500	60	125	2×10 <sup>4</sup>	-25 to +85
	<b>EK32-080M</b>	50	500	60	125	2×10 <sup>4</sup>	-25 to +85

• The operating temp. range includes the self-temp. rise.

### Shape and Dimensions

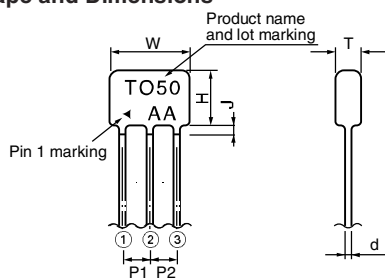

Model	W max.	H max.	T max.	P <sub>1</sub> +0.4 -0.2	P <sub>2</sub> +0.4 -0.2	J max.	d ±0.05	Per Box
<b>30 type</b>	8.0	12.0	5.0	2.5	2.5	1.0	0.5	1000
<b>31 type</b>	7.0	5.0	2.5	2.5	2.5	1.0	0.5	2000
<b>32 type</b>	7.5	9.5	3.5	2.5	2.5	1.0	0.5	1500

[mm]

### Circuit Diagram

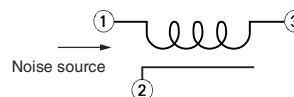

### Numbering System

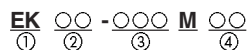

- ① Series
- ② Type
- ③ Nominal cut-off frequency
- ④ TF : Taping (EK 30 type: 1000 pcs./ box, EK 31 type: 2000pcs./box, EK 32 type: 1500 pcs./ box)

**Attenuation Characteristics**

●EK 30, EK 31 Type

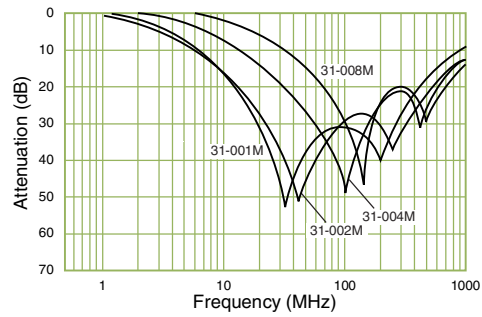
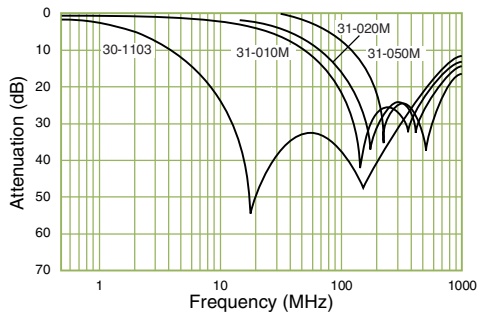

●EK 32 Type

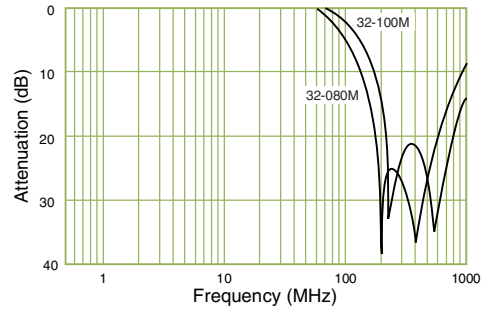
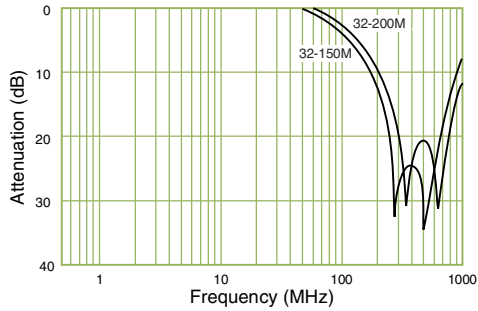

# Distributed Constant Filters

## EK 33



• Tape and Reel Dimensions (see page 35)

Model	Rated voltage DC (V)	Rated current DC (mA)	Dielectric breakdown voltage DC (V)	Insulation resistance (MΩ) min.	DC resistance (MΩ) max.	Capacitance (Reference) C (pF)	Operating temperature range (°C)	Attenuation level (dB) min.
<b>EK33-250NB</b>	50	500	125	3×10 <sup>4</sup>	85	25	-25 to +85	10 (at 260 to 700 MHz)
<b>EK33-500NB</b>	50	500	125	3×10 <sup>4</sup>	140	50	-25 to +85	10 (at 120 to 800 MHz)
<b>EK33-131NB</b>	50	500	125	3×10 <sup>4</sup>	200	130	-25 to +85	10 (at 60 to 800 MHz)

• The operating temperature range includes self-temperature rise.

### Shape and Dimensions

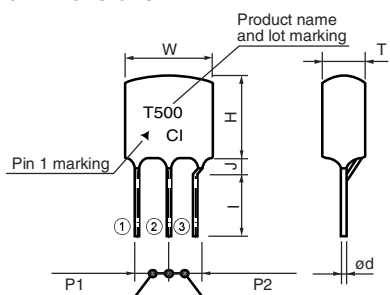

Model	W max.	H max.	T max.	P <sub>1</sub> +0.4 -0.2	P <sub>2</sub> +0.4 -0.2	J max.	d ±0.05	Per Box
<b>EK33-250NB</b>	8.3	10.0	4.5	2.5	2.5	2.0	0.5	1000
<b>EK33-500NB</b>	8.3	10.0	4.5	2.5	2.5	2.0	0.5	1000
<b>EK33-131NB</b>	9.0	7.5	4.5	3.5	2.5	2.0	0.5	1000

[mm]

### Circuit Diagram

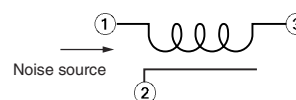

### Numbering System

**EK** - ①② - ③④⑤⑥⑦⑧⑨⑩ - ⑪⑫

- ① Series
- ② Type
- ③ Capacitance
- ④ TF : Flat taping (1000 pcs./box)

### Attenuation Characteristics

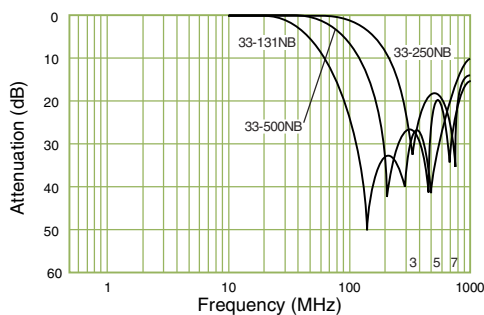

# Feedthrough Capacitor Filters EG Series

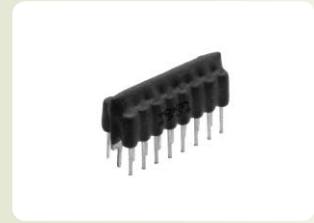

Model	Rated voltage DC (V)	Rated current (A) max.	Operating temperature range (°C)	Storage temperature range (°C)
EG-□□□□□	50	5	-25 to +85	-40 to +100

• Withstanding voltage: 125VDC • Insulation resistance: 1000MΩ

## Shape and Dimensions

### ●EG-8 type

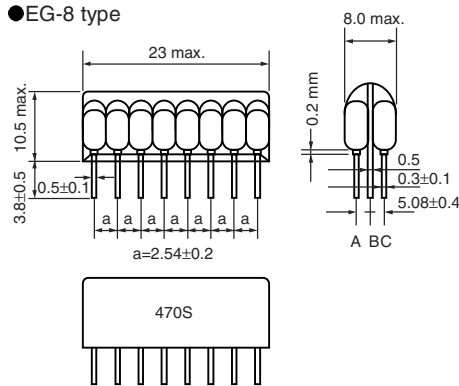

### ●EEG-4 type

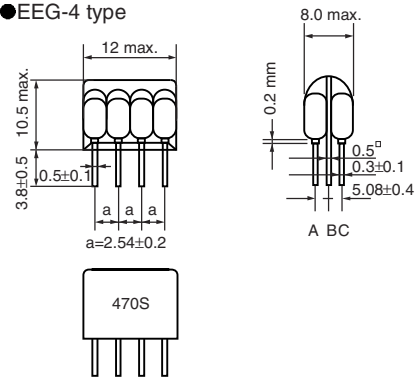

[mm]

## Circuit Diagram

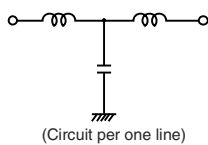

## Numbering System

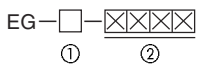

① 3:3 line, 4:4 line, 8:8 line  
② 470S : 47pF, 101S : 100pF, 271S : 270pF, 471P : 470pF, 102P : 1,000pF

## Attenuation Characteristics

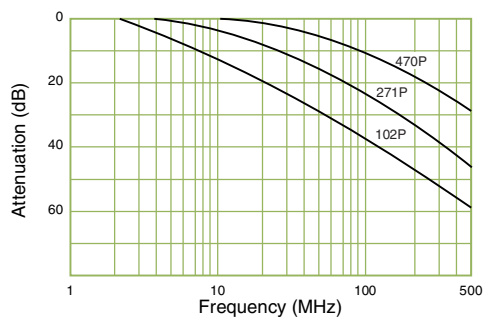

# EJ Series



Model	Rated voltage DC (V)	Rated current (A) max.	Operating temperature range (°C)	Storage temperature range (°C)
EJ-2-332P	50	10	-25 to +85	-40 to +100

- Withstanding voltage: 300VDC, 1 to 5 seconds, between lines (INPUT-OUTPUT-GROUND)
- Insulation resistance: more than 1000MΩ (50VDC, one minute)

## Shape and Dimensions

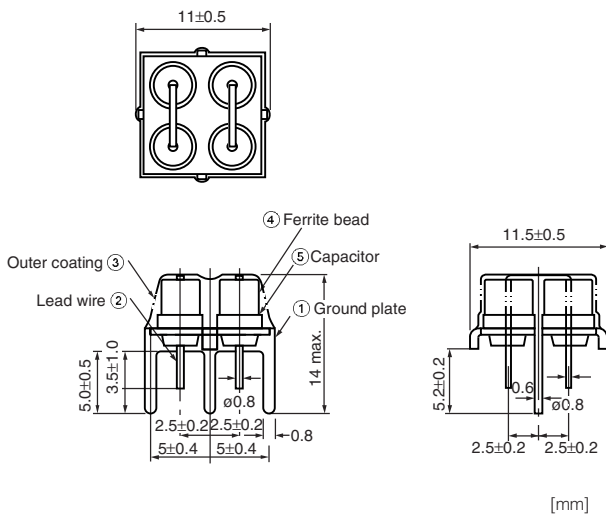

## Circuit Diagram

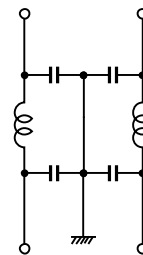

## Attenuation Characteristics

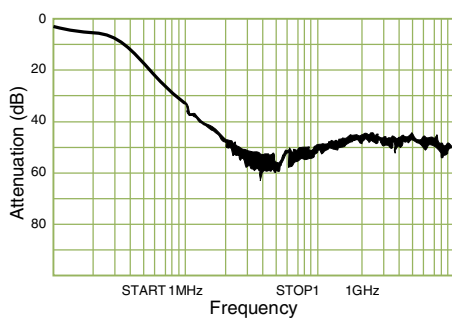



# DFD Series

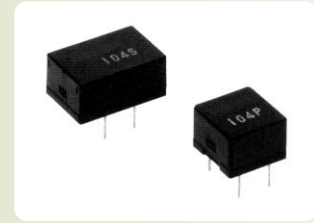

Model	Rated voltage DC (V)	Rated current DC (A)	DC resistance (mΩ) max.	Operating temperature range (°C)
<b>DFD-104P</b>	50	2.0	100	-25 to +85
<b>DFD-104S</b>	50	2.0	100	-25 to +85

• Withstanding voltage: 125VDC, 5 sec. between terminal 1 and 2 • Insulation resistance: more than 500MΩ (100VDC, one minute)

## Shape and Dimensions/Circuit Diagram

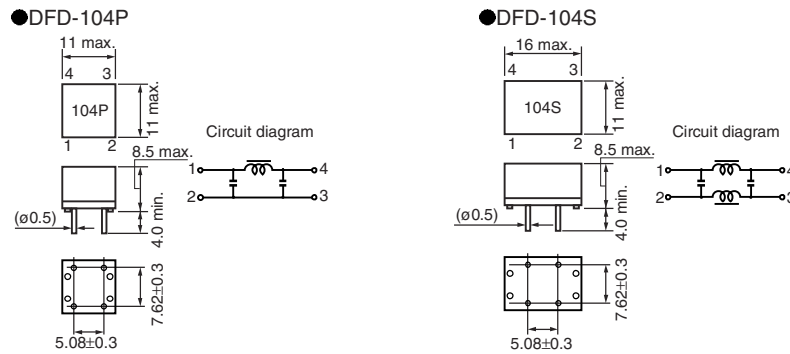

[mm]

## Attenuation Characteristics

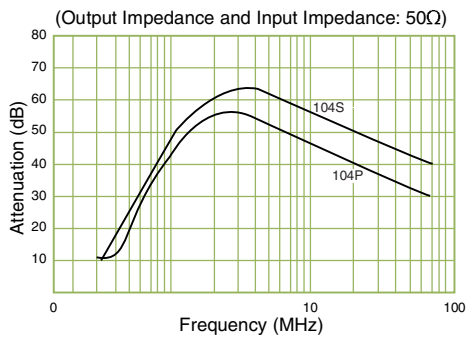

Tape and Reel Dimensions

**SBT Series**

Tape and Reel Dimensions

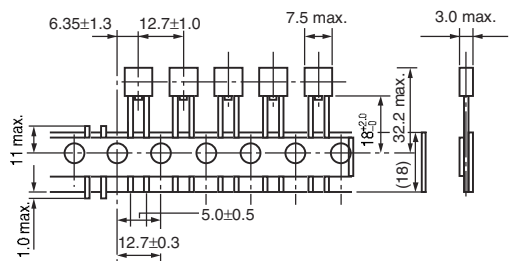

**SNT Series**

Tape and Reel Dimensions

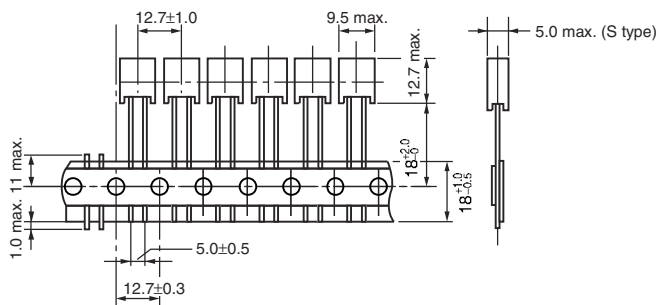

**Distributed Constant Filters EK 30, 31, 32**

Tape and Reel Dimensions

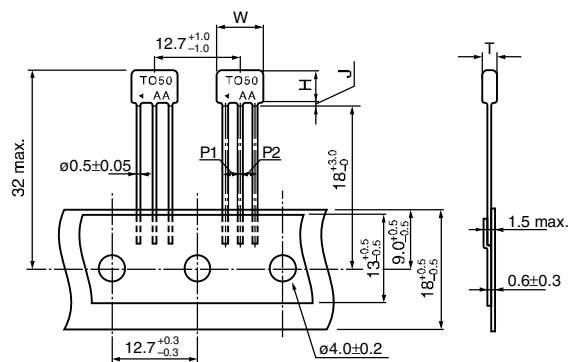

Model	W		H	T	P <sub>1</sub>		P <sub>2</sub>		J	d	Per Box
	max.	max.	max.	max.	+0.4, -0.2	+0.4, -0.2	max.	±0.05			
<b>30 type</b>	8.0	12.0	5.0	2.5	2.5	2.5	1.0	0.5	1000		
<b>31 type</b>	7.0	5.0	2.5	2.5	2.5	2.5	1.0	0.5	2000		
<b>32 type</b>	7.5	9.5	3.5	2.5	2.5	2.5	1.0	0.5	1500		

Distributed Constant Filters EK33

Tape and Reel Dimensions

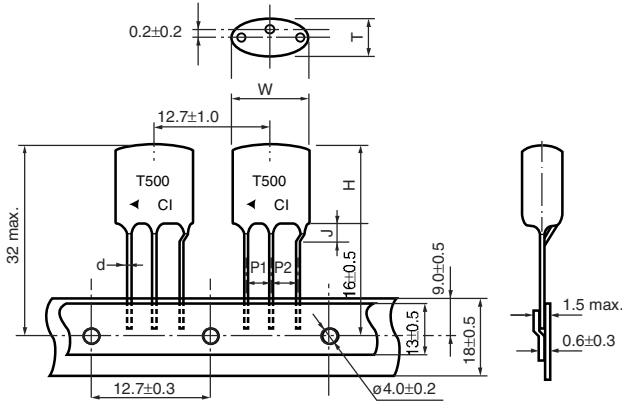

Model	W	H	T	P <sub>1</sub>	P <sub>2</sub>	J	d	Per Box
	max.	max.	max.	+0.4, -0.2	+0.4, -0.2	max.	±0.05	
<b>EK33-250NB</b>	8.3	10.0	4.5	2.5	2.5	2.0	0.5	1000
<b>EK33-500NB</b>	8.3	10.0	4.5	2.5	2.5	2.0	0.5	1000
<b>EK33-131NB</b>	9.0	7.5	4.5	3.5	2.5	2.0	0.5	1000

# SBS-9080 Series



• Tape and Reel Dimensions (see page 45) • Precautions (see page 44)

Model	Rated voltage DC (V)	Rated current DC (A)	Impedance (at 180MHz) (Ω) typ.	DC resistance (mΩ/line) max.	Operating temperature range (°C)
<b>SBS9080-509T</b>	50	5.0	1200	15	-25 to +50

• Withstanding voltage: 125V DC for one minute between lines • Insulation resistance: More than 10MΩ (100V DC, between lines)

## Shape and Dimensions

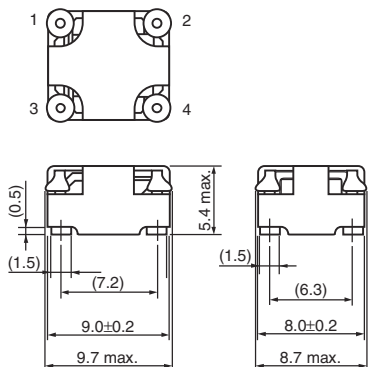

[mm]

## Circuit Diagram

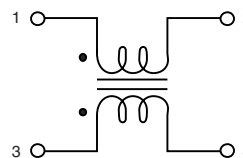

## Recommended Land Pattern

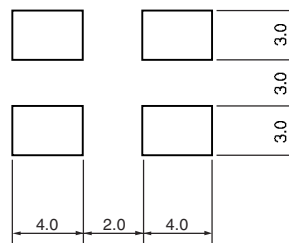

[mm]

## Impedance vs. Frequency

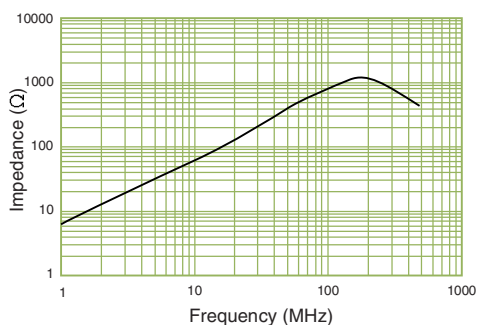

# SBP Series



- Tape and Reel Dimensions (see page 45)
- Precautions (see page 44)

Model	Rated voltage DC (V)	Rated current DC (A)	Impedance (at 100MHz) ( $\Omega$ ) min.	DC resistance (m $\Omega$ /line) max.	Operating temperature range ( $^{\circ}$ C)
<b>SBP-5001T</b>	50	5.0	500	7	-25 to +70

- Withstanding voltage: 200V DC for one minute between lines
- Insulation resistance: More than 10M $\Omega$  (100V DC, between lines)

### Shape and Dimensions

[mm]

### Circuit Diagram

### Recommended Land Pattern

[mm]

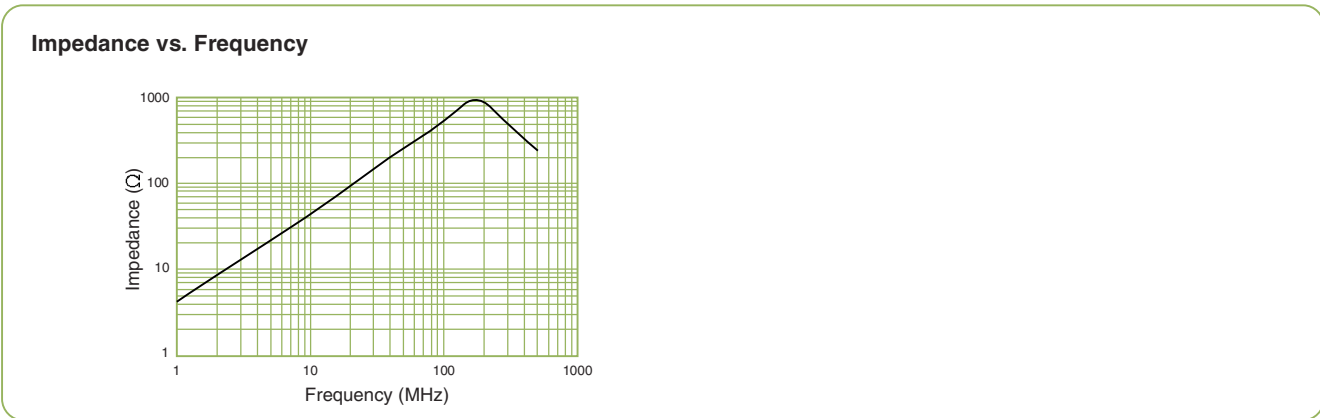

# DCM Series



• Tape and Reel Dimensions (see page 47) • Precautions (see page 44)

Model	Rated voltage (V)	Rated current (A)	L (μH) min	Rdc(mΩ) max	Type
DCM5-01	50	0.2	2540	3180	EE5
DCM5-02	50	0.5	520	510	EE5
DCM5-03	50	1.0	210	180	EE5
DCM5-04	50	2.0	30	30	EE5
DCM11-01	50	0.8	1350	240	ED11.6/5
DCM11-02	50	1.3	630	105	ED11.6/5

● Inductance measurement condition : f = 10KHZ 0.1V ※● Insulation resistance : more than 100MΩ (DC250V, 1min, between lines) ● Operating temperature range(°C) : -20 to 110 (includes the selftemp.rise)  
**Look :** By number-of-turns adjustment, to products other than the above-mentioned characteristic is also possible, please consult.  
 ● Common mode winding with section bobbin. ※● Withstanding voltage : 250V DC for one minute between lines.

## Shape and Dimensions

### ●DCM5 Series

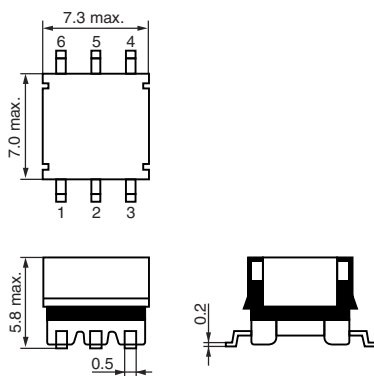

### ●DCM11 Series

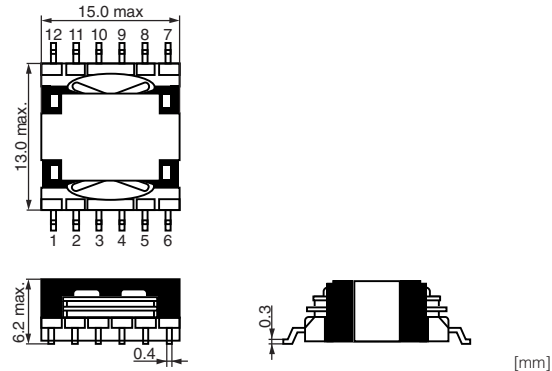

## Recommended Land Pattern

### ●DCM5 Series

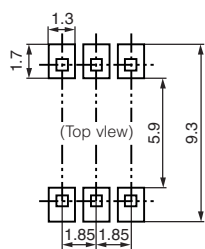

### ●DCM11 Series

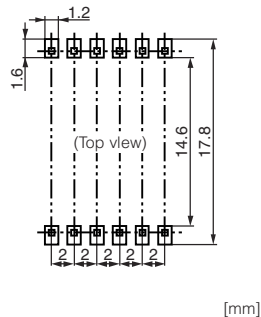

## Circuit Diagram

### ●DCM5 Series

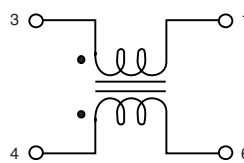

### ●DCM11 Series

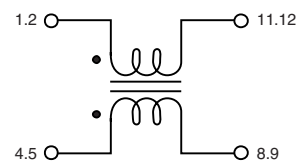

Impedance vs. Frequency

— Common-mode  
 - - - Normal-mode

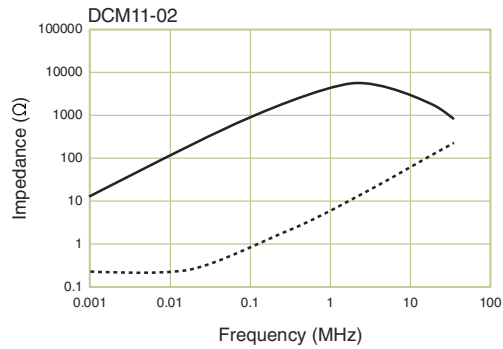
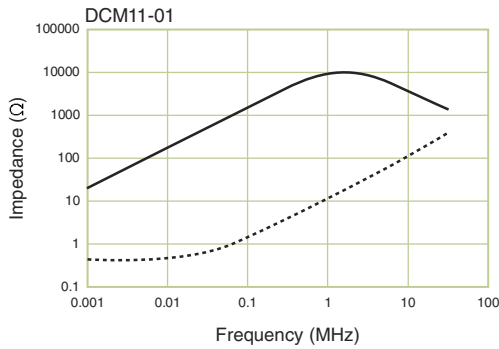
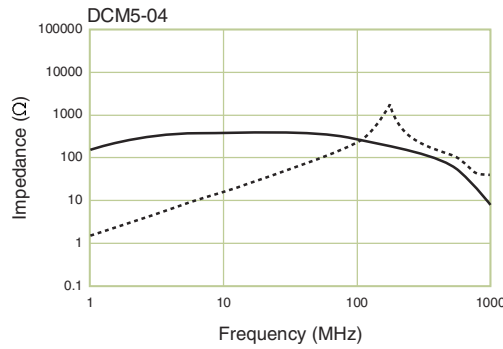
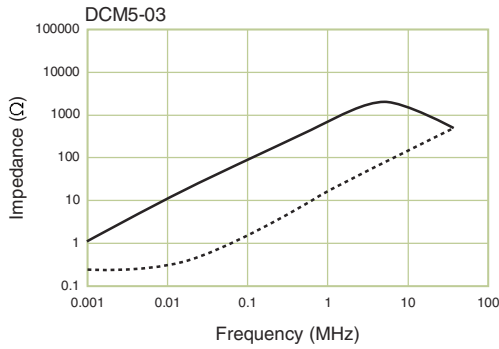
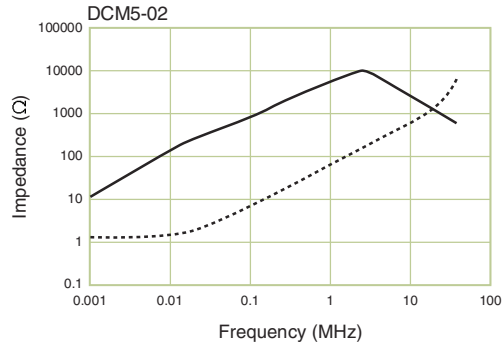
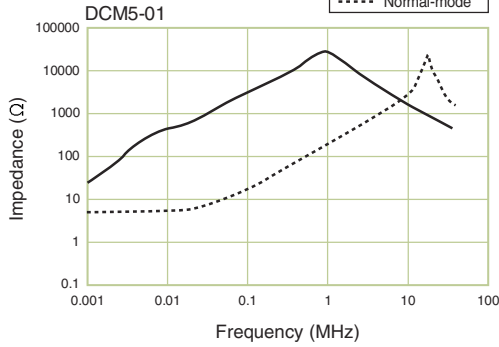

# EMC Chip Filters M-500CT/M-600T Series



• Tape and Reel Dimensions (see page 45-47) • Precautions (see page 44)

## M-500CT Series

Model	Rated voltage DC (V)	Rated current DC (A)	Impedance (Ω) min.	DC resistance (mΩ) max.	Operating temperature range (°C)
M-521CT	50	1.0	700 (at 10 MHz)	100	-25 to +85
M-522CT	50	1.0	200 (at 20 MHz)	100	-25 to +85
M-523CT	50	1.5	200 (at 20 MHz)	65	-25 to +85
M-532CT	50	0.5	450 (at 100 MHz)	90	-25 to +85
M-538CT	50	0.1	800 (at 100 MHz)	220	-25 to +70
M-542CT	50	0.5	200 (at 10 MHz)	120	-20 to +75

## M-600T Series

Model	Rated voltage DC (V)	Rated current DC (A)	Impedance (Ω) min.	DC resistance (mΩ) max.	Operating temperature range (°C)
M-608T	50	0.1	300 (at 100 MHz)	80	-20 to +80
M-614T	50	0.1	1000 (at 50 MHz)	120	-20 to +80
M-620T	50	0.1	1000 (at 30 MHz)	160	-20 to +80

• Insulation resistance: more than 10MΩ (100V DC, between lines)

### Shape and Dimensions

● M-521CT, M-522CT, M-523CT

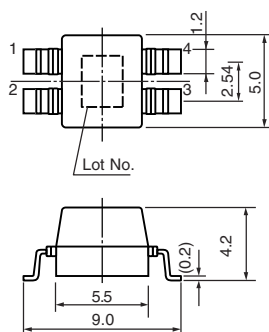

● M-532CT, M-538CT

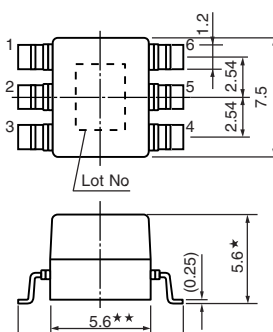

\* M-538CT: 3.5  
\*\* M-538CT: 5.8

● M-542CT

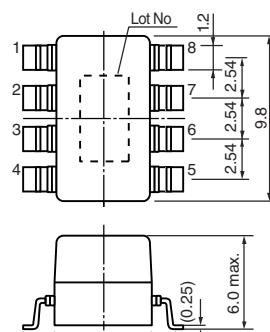

tolerance:±0.2

● M-608T, M-614T, M-620T

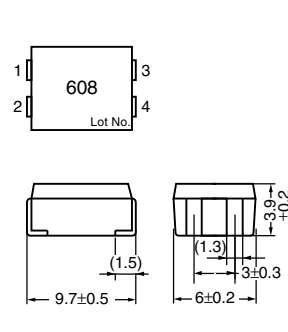

[mm]

### Circuit Diagram

● M-521CT, M-522CT, M-523CT

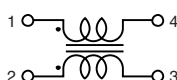

● M-532CT, M-538CT

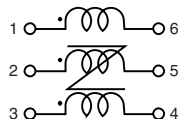

● M-542CT

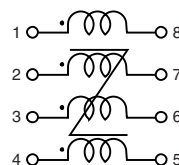

● M-608T, M-614T, M-620T

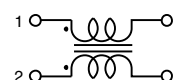



Recommended Land Pattern

●M-521CT, M-522CT, M-523CT

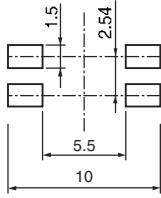

●M-538CT

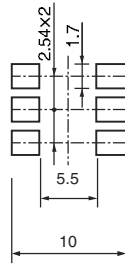

●M-542CT

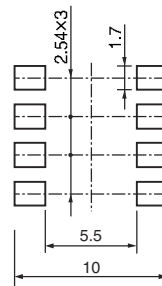

●M-608T, M-614T, M-620T

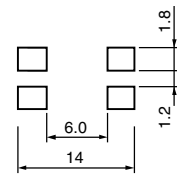

[mm]

Impedance vs. Frequency

M-500CT Series

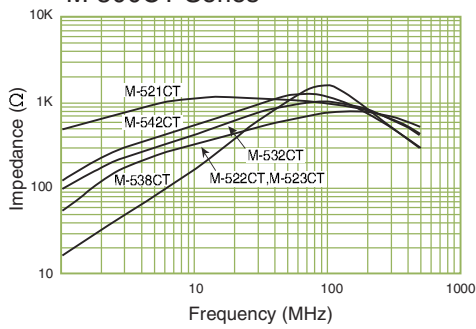

M-600T Series

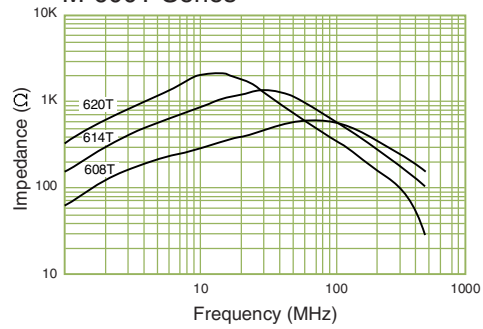

# SCM Series

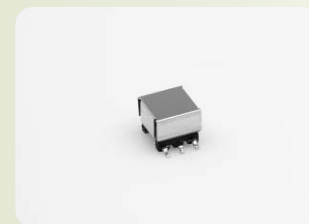

• Tape and Reel Dimensions (see page 47) • Precautions (see page 44)

Model	Rated voltage (V)	Rated current (A)	L (μH) min	Rdc (mΩ) max
SCM5-01	50	0.2	2540	3180
SCM5-02	50	0.5	520	510
SCM5-03	50	1.0	210	180
SCM5-04	50	2.0	30	30

● Inductance measurement condition : f = 10KHZ 0.1V ※● Insulation resistance : more than 100MΩ(DC100V, 1min, between lines) ● Operating temperature range(°C) : -20 to 110(includes the selftemp.rise)  
**Look :** By number-of-turns adjustment, correspondence to products other than the above-mentioned characteristic is also possible, please consult.  
 ● Bitiller winding. ※● Withstanding voltage : 100V DC for one minute between lines.

### Shape and Dimensions

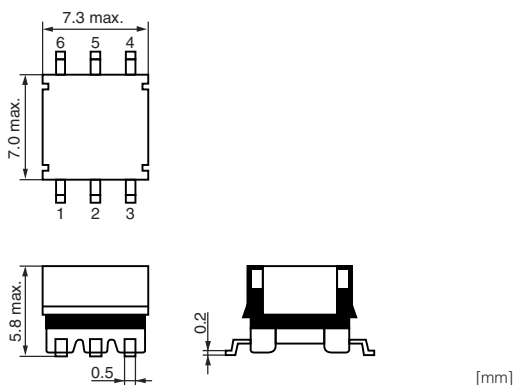

### Recommended Land Pattern

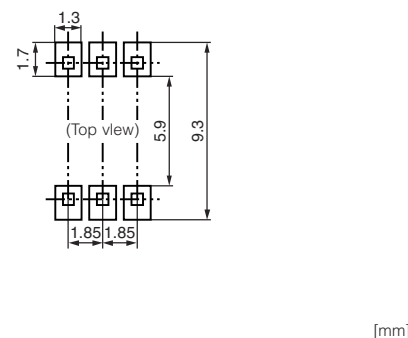

### Circuit Diagram

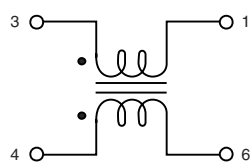

### Impedance vs. Frequency

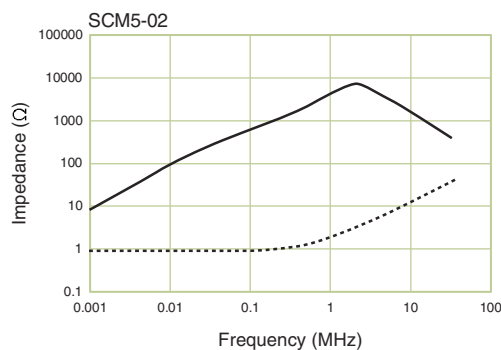
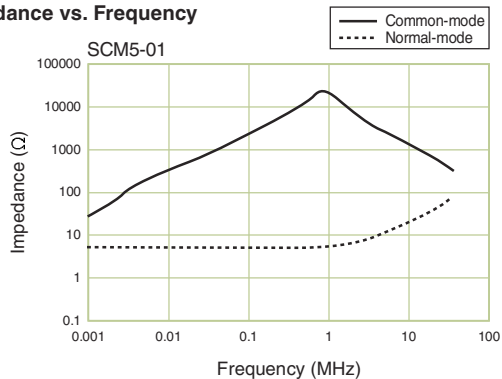

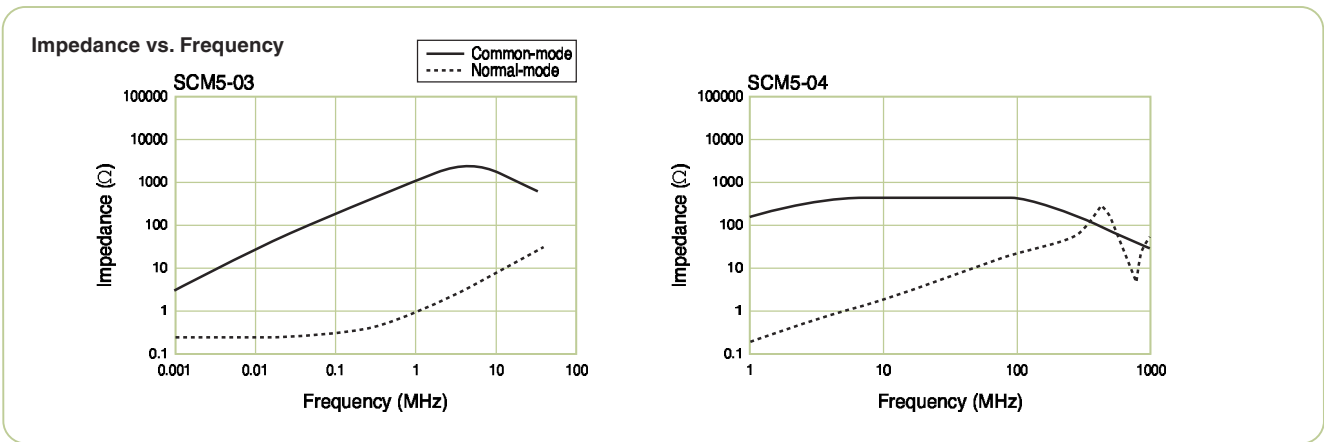

Precautions

Shelf Life

Use within 6 months. If the product is used after a storage period of 6 months or longer, confirm its solderability before use.

Recommended Soldering Conditions

- Soldering irons:  
Tip temperature:  $300 \pm 5^{\circ}\text{C}$   
Duration of heat: approx. 4 seconds
- Flow soldering: not suitable
- Reflow soldering: Refer to the following temperature profile.

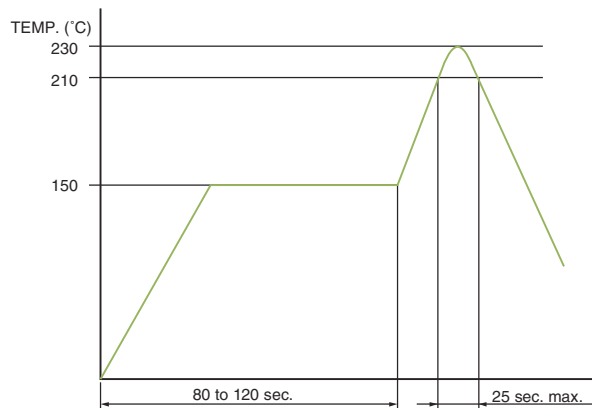

Tape and Reel Dimensions

SBS9080 (1000pcs./reel)

Dimensions of indented square-hole plastic tape

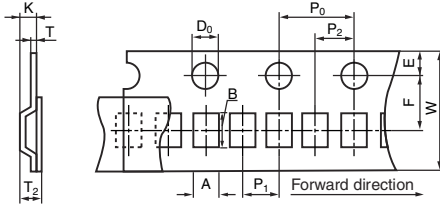

												[mm]
A <sub>0</sub>	B <sub>0</sub>	W	F	E	P <sub>1</sub>	P <sub>2</sub>	P <sub>0</sub>	D <sub>0</sub>	T <sub>1</sub>	T <sub>2</sub>	K	
±0.3	±0.3	±0.3	±0.1	±0.1	±0.1	±0.1	±0.1	+0.1, -0	0.6≥	7.2≥	7.0≥	
9.5	10.3	16	7.5	1.75	12	2.0	4.0	1.5	0.6	7.2	7.0	

Reel dimensions

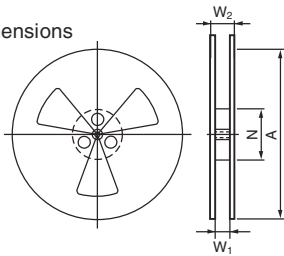

				[mm]
A	N	W <sub>1</sub>	W <sub>2</sub>	
		±0.5	25≥	
330	100	17.5	25	

SBP-5001T (1000pcs./reel)

Dimensions of indented square-hole plastic tape

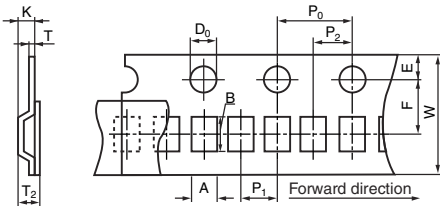

												[mm]
A	B	W	F	E	P <sub>1</sub>	P <sub>2</sub>	P <sub>0</sub>	D <sub>0</sub>	T <sub>1</sub>	T <sub>2</sub>	K	
±0.3	±0.3	±0.3	±0.1	±0.1	±0.1	±0.1	±0.1	+0.1, -0	0.4≥	5.7≥	5.8≥	
9.0	9.0	16	7.5	1.75	12	2.0	4.0	1.5	0.4	5.7	5.8	

Reel dimensions

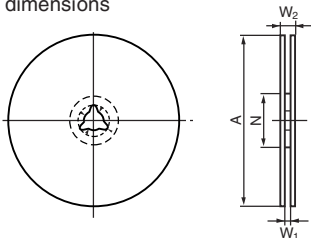

				[mm]
A	N	W <sub>1</sub>	W <sub>2</sub>	
		+6, -0	25≥	
330	79	16	25	

M-521CT/M-522CT/M-523CT (conforms to EIAJ RC-1009) (1500pcs./reel)

Dimensions of indented square-hole plastic tape

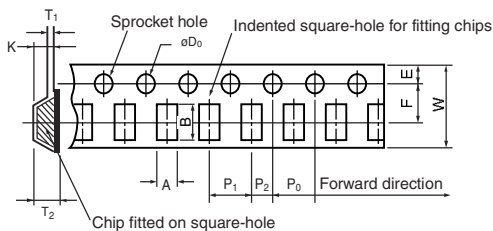

												[mm]
A	B	W	F	E	P <sub>1</sub>	P <sub>2</sub>	P <sub>0</sub>	D <sub>0</sub>	T <sub>1</sub>	T <sub>2</sub>	K	
±0.3	±0.3	±0.3	±0.1	±0.1	±0.1	±0.1	±0.1	+0.1, -0	max.	max.	max.	
5.3	9.5	16	7.5	1.75	8.0	2.0	4.0	1.5	0.6	6.5	6.4	

Reel dimensions

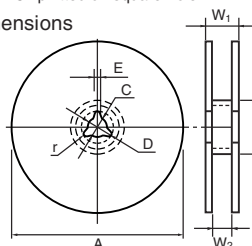

								[mm]
A	B	C	D	E	r	W <sub>1</sub>	W <sub>2</sub>	
±3.0	±2.0	±0.2	±0.8	±0.5	—	max.	+6, -0	
330	79	13	21	2.0	1.0	25	16	

**M-532CT (conforms to EIAJ RC-1009) (1000pcs./reel)**

Dimensions of indented square-hole plastic tape

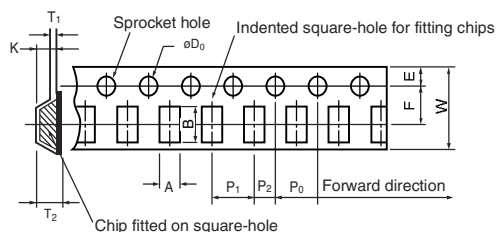

A	B	W	F	E	P <sub>1</sub>	P <sub>2</sub>	P <sub>0</sub>	D <sub>0</sub>	T <sub>1</sub>	T <sub>2</sub>	K
±0.3	±0.3	±0.3	±0.1	±0.1	±0.1	±0.1	±0.1	+0.1, -0	max.	max.	max.
7.9	9.4	16.0	7.5	1.75	12.0	2.0	4.0	1.5	0.6	6.9	6.8

Reel dimensions

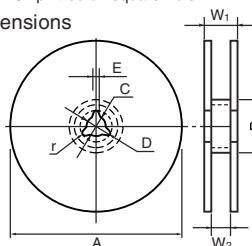

A	B	C	D	E	r	W <sub>1</sub>	W <sub>2</sub>
±3.0	±2.0	±0.2	±0.8	±0.5	—	max.	+6, -0
330	80	13.0	21.0	2.0	1.0	25.0	16.0

**M-538CT (conforms to EIAJ RC-1009) (1500pcs./reel)**

Dimensions of indented square-hole plastic tape

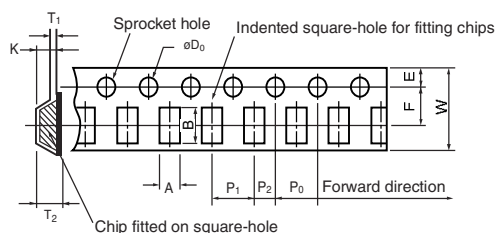

A	B	W	F	E	P <sub>1</sub>	P <sub>2</sub>	P <sub>0</sub>	D <sub>0</sub>	T <sub>1</sub>	T <sub>2</sub>	K
±0.3	±0.3	±0.3	±0.1	±0.1	±0.1	±0.1	±0.1	+0.1, -0	max.	max.	max.
7.9	9.4	16.0	7.5	1.75	12.0	2.0	4.0	1.5	0.6	4.6	4.5

Reel dimensions

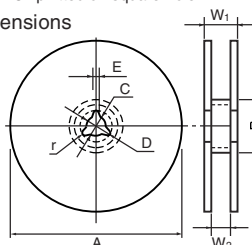

A	B	C	D	E	r	W <sub>1</sub>	W <sub>2</sub>
±3.0	±2.0	±0.2	±0.8	±0.5	—	max.	+6, -0
330	80	13.0	21.0	2.0	1.0	25.0	16.0

**M-542CT (conforms to EIAJ RC-1009) (1000pcs./reel)**

Dimensions of indented square-hole plastic tape

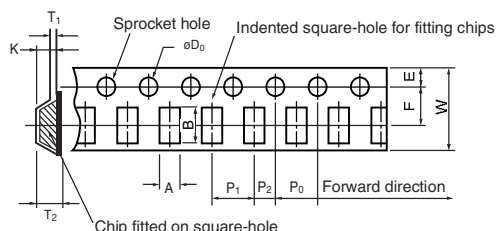

A	B	W	F	E	P <sub>1</sub>	P <sub>2</sub>	P <sub>0</sub>	D <sub>0</sub>	T <sub>1</sub>	T <sub>2</sub>	K
±0.3	±0.3	±0.3	±0.1	±0.1	±0.1	±0.1	±0.1	+0.1, -0	max.	max.	max.
9.5	10.5	16.0	7.5	1.75	12.0	2.0	4.0	1.5	0.6	7.2	7.0

Reel dimensions

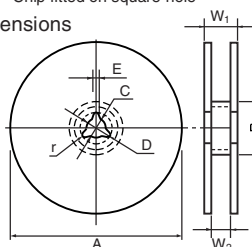

A	B	C	D	E	r	W <sub>1</sub>	W <sub>2</sub>
±3.0	±2.0	±0.2	±0.8	±0.5	—	max.	+6, -0
330	100	13.0	21.0	2.0	1.0	25.0	17.5±0.5

**M-608T/M-614T/M-620T (conforms to EIAJ RC-1009) (1500pcs./reel)**

Dimensions of indented square-hole plastic tape

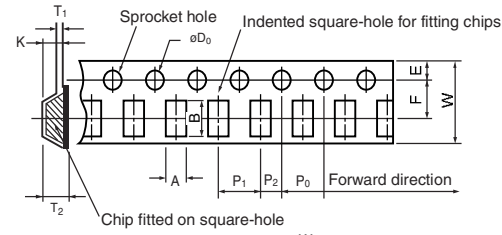

												[mm]
A	B	W	F	E	P <sub>1</sub>	P <sub>2</sub>	P <sub>0</sub>	D <sub>0</sub>	T <sub>1</sub>	T <sub>2</sub>	K	
±0.3	±0.3	±0.3	±0.1	±0.1	±0.1	±0.1	±0.1	+0.1, -0	max.	max.	max.	
6.4	10.2	16.0	7.5	1.75	8.0	2.0	4.0	1.5	0.6	6.5	6.4	

Reel dimensions

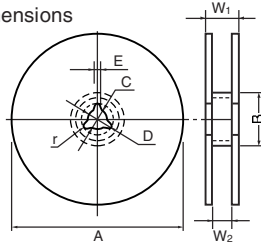

								[mm]
A	B	C	D	E	r	W <sub>1</sub>	W <sub>2</sub>	
±3.0	±2.0	±0.2	±0.8	±0.5	—	max.	+6, -0	
330	79	13.0	21.0	2.0	1.0	25.0	16.0	

**DCM5/SCM5 Series (2000pcs /reel)**

Dimensions of indented square-hole plastic tape

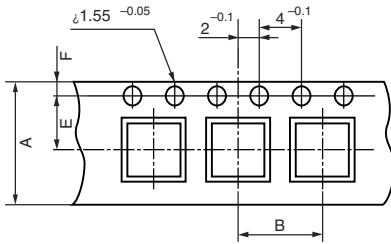

Model	A	B	C	D	E	F	G	H
SCM5 Series	16±0.3	8.0	6.3	8.3	7.5	1.75	5.2	0.38±0.05
DCM5 Series	24±0.3	20	14.5	17.2	11.5	1.75	6.8	0.38±0.05

