

OKI electronic components

KGF1145

Small-Signal Amplifier

GENERAL DESCRIPTION

The KGF1145 is a two-stage small-signal UHF-band amplifier that features low current operation, high output power, and high isolation. The KGF1145 specifications are guaranteed to a fixed matching circuit for 5 V and 850 MHz; external impedance-matching circuits are also required. Because of the high isolation, the KGF1145 is an ideal part for VCO-buffer amplifiers and intermediate stage amplifiers for portable handy phones, such as cellular phones.

FEATURES

- Low current operation: 4 mA (max.)
- High output power: 2 dBm (min.)
- High isolation: -40 dB
- Self-bias circuit configuration with built-in source capacitor
- Package: 4PSOP

PACKAGE DIMENSIONS

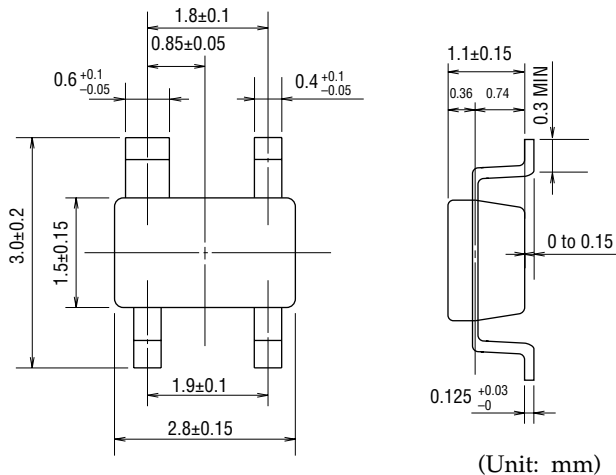

Package material	Epoxy resin
Lead frame material	42 alloy
Pin treatment	Solder plating
Solder plate thickness	5 μ m or more

MARKING

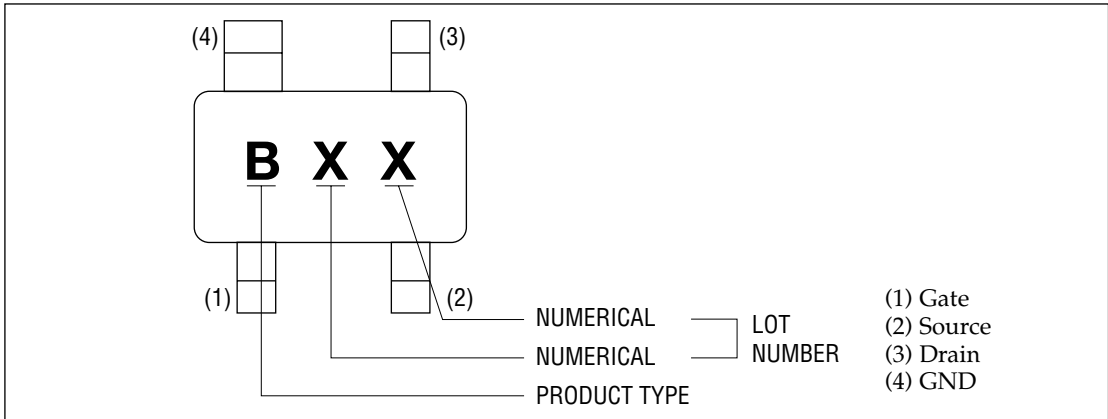

CIRCUIT

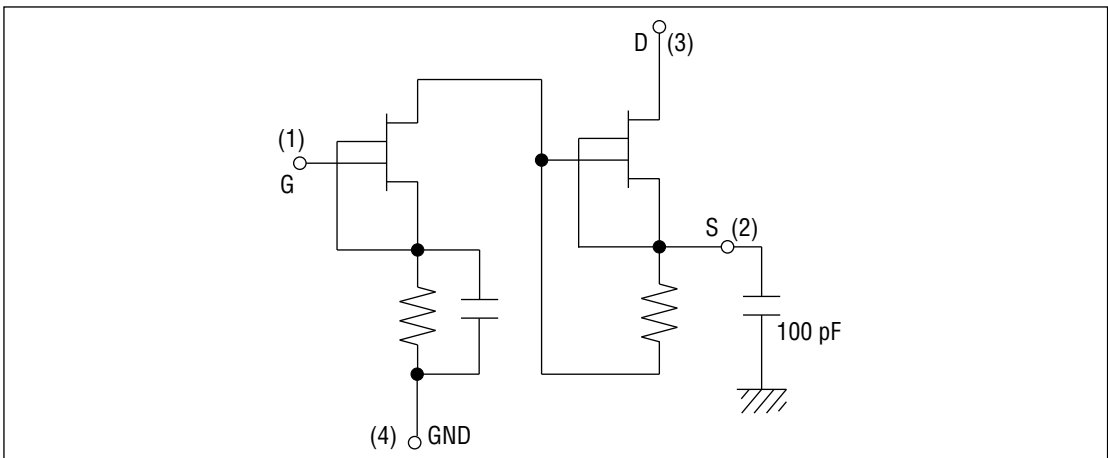

APPLICATION EXAMPLE FOR PORTABLE PHONES

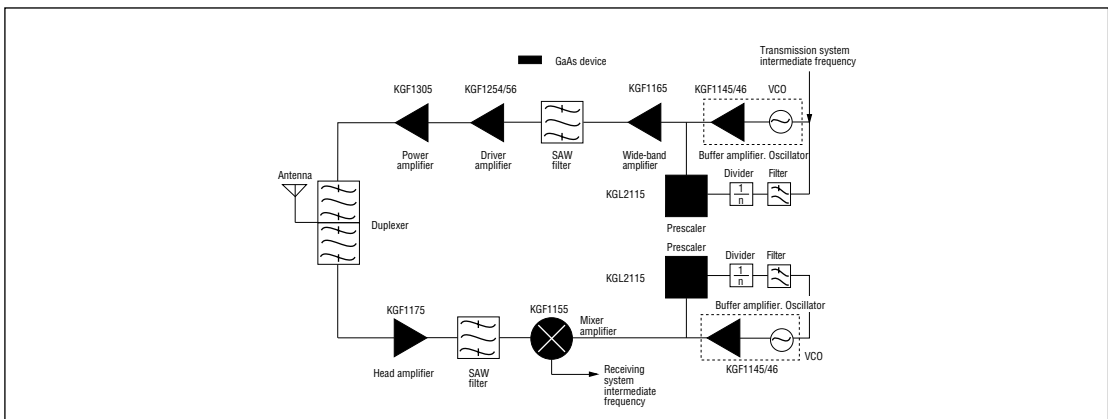

ABSOLUTE MAXIMUM RATINGS

(Ta = 25°C)

Item	Symbol	Unit	Min.	Max.
Drain-source voltage	V _{DS}	V	—	6
Gate-source voltage	V _{GS}	V	-3	0.4
Drain current	I _{DS}	mA	—	60
Total power dissipation	P _{tot}	mW	—	200
Channel temperature	T _{ch}	°C	—	150
Storage temperature	T _{stg}	°C	-45	125

ELECTRICAL CHARACTERISTICS

(Ta = 25°C)

Item	Symbol	Condition	Unit	Min.	Max.
Gate-source leakage current	I _{GSS}	V _{GS} = -3 V	μA	—	12
Gate-drain leakage current	I _{GDO}	V _{GDO} = -6 V	μA	—	60
Drain-source leakage current	I _{DS(off)}	V _{DS} = 3 V, V _{GS} = -2.5 V	μA	—	120
Drain current	I _{DSS}	V _{DS} = 3 V, V _{GS} = 0 V	mA	15	—
Operating current	I _D	(*1), P _{IN} = -10 dBm	mA	—	4
Gate-source cut-off voltage	V _{GS(off)}	V _{DS} = 3 V, I _{DS} = 120 μA	V	-2.0	-1.0
Transconductance	g _m	V _{DS} = 3 V, I _{DS} = 2.5 mA	mS	8	—
Output power	P _O	(*1), P _{IN} = -10 dBm	dBm	2	—
Isolation	ISO	(*1), P _{IN} = -10 dBm	dB	40	—

*1 Self-bias condition: V_{DD} = 5.0 ± 0.25 V, V_G = 0 V, f = 850 MHz

CHARACTERISTICS

P_o vs. P_{IN}

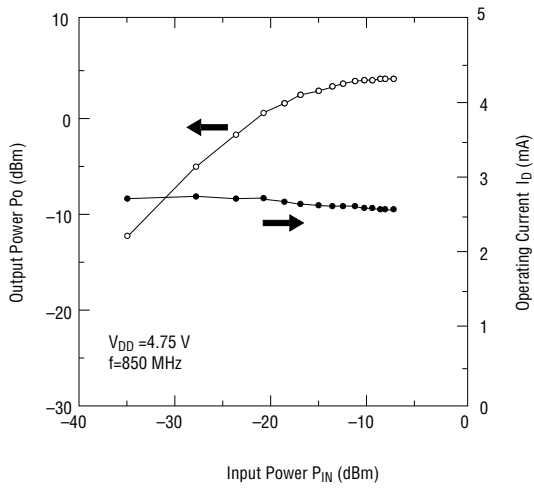

Typical S Parameters

 $V_{DD} = 5\text{ V}$, $I_D = 2.70\text{ mA}$

Freq(MHz)	MAG(S ₁₁)	ANG(S ₁₁)	MAG(S ₂₁)	ANG(S ₂₁)	MAG(S ₁₂)	ANG(S ₁₂)	MAG(S ₂₂)	ANG(S ₂₂)
500.0	1.019	-13.30	4.379	-47.41	0.002	68.37	0.922	-7.57
600.0	1.014	-15.83	4.408	-59.30	0.001	68.30	0.921	-8.97
700.0	1.004	-18.55	4.273	-70.90	0.002	76.00	0.920	-10.50
800.0	0.997	-21.19	4.200	-79.69	0.001	103.87	0.918	-11.77
900.0	0.989	-23.73	4.021	-88.70	0.002	70.31	0.918	-13.39
1000.0	0.979	-26.33	3.914	-96.04	0.001	41.49	0.912	-14.69
1100.0	0.970	-28.86	3.594	-103.81	0.002	39.66	0.913	-16.08
1200.0	0.958	-31.41	3.432	-109.87	0.002	69.82	0.910	-17.60
1300.0	0.949	-33.99	3.195	-115.80	0.003	40.98	0.909	-18.98
1400.0	0.936	-36.74	3.019	-120.72	0.001	91.26	0.901	-20.60
1500.0	0.926	-39.31	2.806	-126.82	0.001	106.35	0.901	-21.77
1600.0	0.914	-42.03	2.627	-131.34	0.001	87.82	0.898	-23.04
1700.0	0.903	-44.77	2.427	-135.76	0.000	36.68	0.895	-24.52
1800.0	0.889	-47.30	2.318	-141.70	0.001	-107.00	0.889	-25.91
1900.0	0.882	-49.93	2.232	-146.80	0.003	-120.41	0.888	-26.97
2000.0	0.867	-52.61	2.170	-151.72	0.003	-119.09	0.881	-28.24
2100.0	0.856	-55.68	2.118	-156.73	0.004	-120.95	0.878	-29.59
2200.0	0.849	-58.49	2.017	-162.05	0.006	-127.04	0.875	-30.86
2300.0	0.840	-61.23	1.954	-167.23	0.006	-118.02	0.870	-32.08
2400.0	0.829	-64.11	1.903	-172.08	0.010	-117.98	0.867	-33.30
2500.0	0.820	-66.28	1.846	-176.86	0.011	-118.51	0.864	-34.57
2600.0	0.807	-69.20	1.781	178.08	0.012	-121.43	0.863	-35.57
2700.0	0.798	-72.04	1.748	172.95	0.015	-125.86	0.856	-36.57
2800.0	0.783	-75.15	1.705	168.29	0.019	-127.35	0.857	-37.71
2900.0	0.779	-78.39	1.670	163.69	0.024	-123.08	0.850	-38.64
3000.0	0.765	-81.35	1.609	158.74	0.029	-127.91	0.852	-39.54

Typical S Parameters

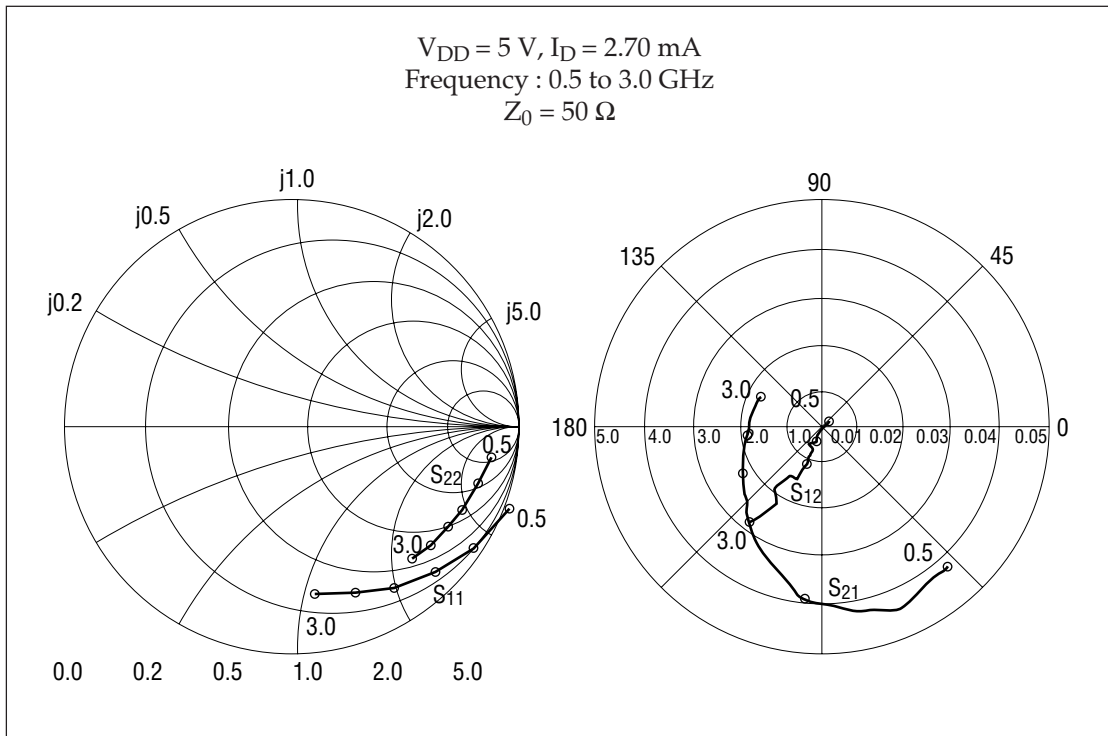

Test Circuit for KGF1145

