

## 3-TERMINAL POSITIVE VOLTAGE REGULATOR

### ■ GENERAL DESCRIPTION

NJM78L00 is 3-terminal positive voltage regulator.  
 NJM78L00 series is mounted in EMP8 package of the surface mount package.  
 The EMP8 package possible flow soldering.

### ■ PACKAGE OUTLINE

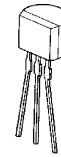

NJM78L00A

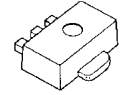

NJM78L00UA

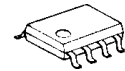

NJM78L00EA  
(5V,9V,12V)

### ■ FEATURES

- Internal Short Circuit Current Limit
- Internal Thermal Overload Protection
- Excellent Ripple Rejection
- Guaranteed 100mA Output Current
- Bipolar Technology
- Package Outline      T0-92,SOT-89,EMP8

### ■ PIN CONFIGURATION

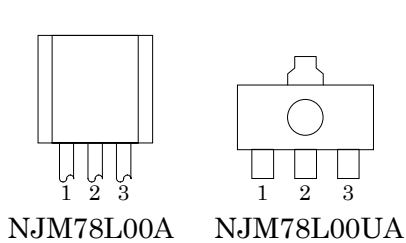

#### PIN FUNCTION

- 1.OUT
- 2.GND
- 3.IN

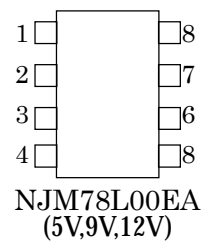

#### PIN FUNCTION

- 1.OUT
- 2.GND
- 3.GND
- 4.NC
- 5.NC
- 6.GND
- 7.GND
- 8.IN

### ■ EQUIVALENT CIRCUIT

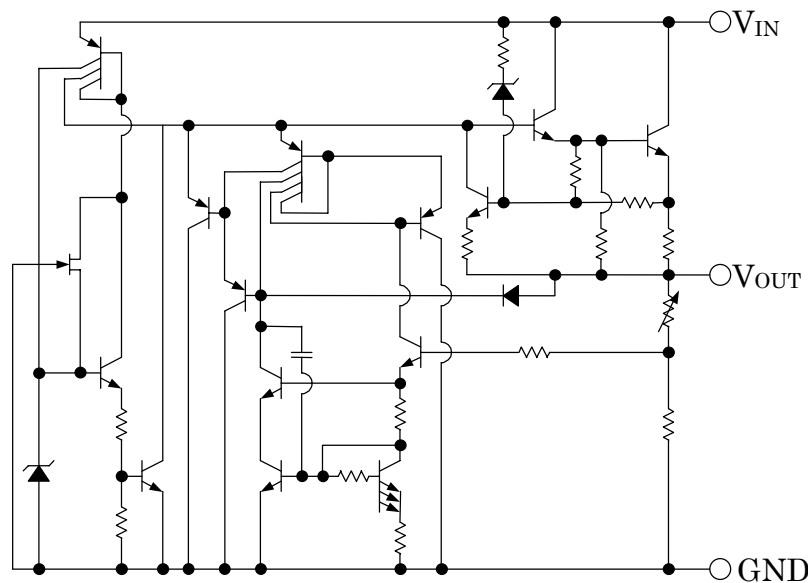

## ■ ABSOLUTE MAXIMUM RATINGS (Ta=25°C)

PARAMETER	SYMBOL	MAXIMUM RATINGS	UNIT
Input Voltage	V <sub>IN</sub>	(78L02A ~ 78L09A) 30	V
		(78L12A ~ 78L15A) 35	
		(78L18A ~ 78L24A) 40	
Power Dissipation	P <sub>D</sub>	(TO-92) 500	mW
		(EMP8) 350	
		(SOT-89) 300	
Operating Temperature Range	Topr	-40 ~ +85	°C
Storage Temperature Range	Tstg	-40 ~ +150	°C

## ■ ELECTRICAL CHARACTERISTICS(C<sub>IN</sub>=0.33μF,Co=0.1μF,Tj=25°C)

Measurement is to be conducted is pulse testing.

PARAMETER	SYMBOL	TEST CONDITION	MIN.	TYP.	MAX.	UNIT
<b>NJM78L02A</b>						
Output Voltage	V <sub>O</sub>	V <sub>IN</sub> =9V, I <sub>O</sub> =40mA	2.47	2.6	2.73	V
Line Regulation1	ΔV <sub>O</sub> -V <sub>IN</sub> 1	V <sub>IN</sub> =4.75V ~ 20V, I <sub>O</sub> =40mA	-	-	125	mV
Line Regulation2	ΔV <sub>O</sub> -V <sub>IN</sub> 2	V <sub>IN</sub> =5V ~ 20V, I <sub>O</sub> =40mA	-	-	100	mV
Load Regulation1	ΔV <sub>O</sub> -I <sub>O</sub> 1	V <sub>IN</sub> =9V, I <sub>O</sub> =1 ~ 40mA	-	-	25	mV
Load Regulation2	ΔV <sub>O</sub> -I <sub>O</sub> 2	V <sub>IN</sub> =9V, I <sub>O</sub> =1 ~ 100mA	-	-	50	mV
Quiescent Current	I <sub>Q</sub>	V <sub>IN</sub> =9V, I <sub>O</sub> =0mA	-	2.0	6	mA
Average Temperature Coefficient of Output Voltage	ΔV <sub>O</sub> /ΔT	V <sub>IN</sub> =9V, I <sub>O</sub> =1mA	-	0.2	-	mV/°C
Ripple Rejection	RR	6V < V <sub>IN</sub> < 16V, I <sub>O</sub> =40mA e <sub>in</sub> =1Vp-p, f=120Hz	43	73	-	dB
Output Noise Voltage	V <sub>NO</sub>	V <sub>IN</sub> =9V, BW=10Hz ~ 100kHz I <sub>O</sub> =40mA	-	35	-	μV
<b>NJM78L03A(*1)</b>						
Output Voltage	V <sub>O</sub>	V <sub>IN</sub> =9V, I <sub>O</sub> =40mA	2.85	3.0	3.15	V
Line Regulation1	ΔV <sub>O</sub> -V <sub>IN</sub> 1	V <sub>IN</sub> =5V ~ 20V, I <sub>O</sub> =40mA	-	-	125	mV
Line Regulation2	ΔV <sub>O</sub> -V <sub>IN</sub> 2	V <sub>IN</sub> =6V ~ 20V, I <sub>O</sub> =40mA	-	-	100	mV
Load Regulation1	ΔV <sub>O</sub> -I <sub>O</sub> 1	V <sub>IN</sub> =9V, I <sub>O</sub> =1 ~ 40mA	-	-	25	mV
Load Regulation2	ΔV <sub>O</sub> -I <sub>O</sub> 2	V <sub>IN</sub> =9V, I <sub>O</sub> =1 ~ 100mA	-	-	50	mV
Quiescent Current	I <sub>Q</sub>	V <sub>IN</sub> =9V, I <sub>O</sub> =0mA	-	2.0	6	mA
Average Temperature Coefficient of Output Voltage	ΔV <sub>O</sub> /ΔT	V <sub>IN</sub> =9V, I <sub>O</sub> =1mA	-	0.2	-	mV/°C
Ripple Rejection	RR	6V < V <sub>IN</sub> < 16V, I <sub>O</sub> =40mA e <sub>in</sub> =1Vp-p, f=120Hz	43	72	-	dB
Output Noise Voltage	V <sub>NO</sub>	V <sub>IN</sub> =9V, BW=10Hz ~ 100kHz, I <sub>O</sub> =40mA	-	40	-	μV
<b>NJM78L05A(*3)</b>						
Output Voltage	V <sub>O</sub>	V <sub>IN</sub> =10V, I <sub>O</sub> =40mA	4.75	5.0	5.25	V
Line Regulation1	ΔV <sub>O</sub> -V <sub>IN</sub> 1	V <sub>IN</sub> =7V ~ 20V, I <sub>O</sub> =40mA	-	-	200	mV
Line Regulation2	ΔV <sub>O</sub> -V <sub>IN</sub> 2	V <sub>IN</sub> =8V ~ 20V, I <sub>O</sub> =40mA	-	-	150	mV
Load Regulation1	ΔV <sub>O</sub> -I <sub>O</sub> 1	V <sub>IN</sub> =10V, I <sub>O</sub> =1 ~ 40mA	-	-	30	mV
Load Regulation2	ΔV <sub>O</sub> -I <sub>O</sub> 2	V <sub>IN</sub> =10V, I <sub>O</sub> =1 ~ 100mA	-	-	60	mV
Quiescent Current	I <sub>Q</sub>	V <sub>IN</sub> =10V, I <sub>O</sub> =0mA	-	2.0	6	mA
Average Temperature Coefficient of Output Voltage	ΔV <sub>O</sub> /ΔT	V <sub>IN</sub> =10V, I <sub>O</sub> =1mA	-	0.4	-	mV/°C
Ripple Rejection	RR	8V < V <sub>IN</sub> < 18V, I <sub>O</sub> =40mA e <sub>in</sub> =1Vp-p, f=120Hz	40	69	-	dB
Output Noise Voltage	V <sub>NO</sub>	V <sub>IN</sub> =10V, BW=10Hz ~ 100kHz I <sub>O</sub> =40mA	-	70	-	μV

(\*1):SOT-89 package only.

(\*2):TO-92 package only.

(\*3):SOT-89,TO-92, EMP8

**■ ELECTRICAL CHARACTERISTICS**( $C_{IN}=0.33\mu F, C_o=0.1\mu F, T_j=25^\circ C$ )  
 Measurement is to be conducted is pulse testing.

PARAMETER	SYMBOL	TEST CONDITION	MIN.	TYP.	MAX.	UNIT
<b>NJM78L06A</b>						
Output Voltage	$V_o$	$V_{IN}=12V, I_o=40mA$	5.7	6.0	6.3	V
Line Regulation1	$\Delta V_o-V_{IN1}$	$V_{IN}=8.5V \sim 20V, I_o=40mA$	-	-	200	mV
Line Regulation2	$\Delta V_o-V_{IN2}$	$V_{IN}=9V \sim 20V, I_o=40mA$	-	-	150	mV
Load Regulation1	$\Delta V_o-I_o1$	$V_{IN}=12V, I_o=1 \sim 40mA$	-	-	40	mV
Load Regulation2	$\Delta V_o-I_o2$	$V_{IN}=12V, I_o=1 \sim 100mA$	-	-	80	mV
Quiescent Current	$I_Q$	$V_{IN}=12V, I_o=0mA$	-	2.0	6	mA
Average Temperature	$\Delta V_o/\Delta T$	$V_{IN}=12V, I_o=1mA$	-	0.5	-	mV/°C
Coefficient of Output Voltage						
Ripple Rejection	RR	$9V < V_{IN} < 20V, I_o=40mA$ $e_{in}=1V_{p-p}, f=120Hz$	40	67	-	dB
Output Noise Voltage	$V_{NO}$	$V_{IN}=12V, BW=10Hz \sim 100kHz$ $I_o=40mA$	-	80	-	$\mu V$
<b>NJM78L62A(*2)</b>						
Output Voltage	$V_o$	$V_{IN}=12.2V, I_o=40mA$	5.89	6.2	6.51	V
Line Regulation1	$\Delta V_o-V_{IN1}$	$V_{IN}=8.7V \sim 20.2V, I_o=40mA$	-	-	200	mV
Line Regulation2	$\Delta V_o-V_{IN2}$	$V_{IN}=9.2V \sim 20.2V, I_o=40mA$	-	-	150	mV
Load Regulation1	$\Delta V_o-I_o1$	$V_{IN}=12.2V, I_o=1 \sim 40mA$	-	-	40	mV
Load Regulation2	$\Delta V_o-I_o2$	$V_{IN}=12.2V, I_o=1 \sim 100mA$	-	-	85	mV
Quiescent Current	$I_Q$	$V_{IN}=12.2V, I_o=0mA$	-	2.0	6	mA
Average Temperature	$\Delta V_o/\Delta T$	$V_{IN}=12.2V, I_o=1mA$	-	0.5	-	mV/°C
Coefficient of Output Voltage						
Ripple Rejection	RR	$9.2V < V_{IN} < 20.2V, I_o=40mA$ $e_{in}=1V_{p-p}, f=120Hz$	40	67	-	dB
Output Noise Voltage	$V_{NO}$	$V_{IN}=12.2V, BW=10Hz \sim 100kHz$ $I_o=40mA$	-	85	-	$\mu V$
<b>NJM78L07A</b>						
Output Voltage	$V_o$	$V_{IN}=13V, I_o=40mA$	6.65	7.0	7.35	V
Line Regulation1	$\Delta V_o-V_{IN1}$	$V_{IN}=9.5V \sim 22V, I_o=40mA$	-	-	210	mV
Line Regulation2	$\Delta V_o-V_{IN2}$	$V_{IN}=10V \sim 22V, I_o=40mA$	-	-	160	mV
Load Regulation1	$\Delta V_o-I_o1$	$V_{IN}=13V, I_o=1 \sim 40mA$	-	-	45	mV
Load Regulation2	$\Delta V_o-I_o2$	$V_{IN}=13V, I_o=1 \sim 100mA$	-	-	90	mV
Quiescent Current	$I_Q$	$V_{IN}=13V, I_o=0mA$	-	2.1	6	mA
Average Temperature	$\Delta V_o/\Delta T$	$V_{IN}=13V, I_o=1mA$	-	0.55	-	mV/°C
Coefficient of Output Voltage						
Ripple Rejection	RR	$10V < V_{IN} < 20V, I_o=40mA$ $e_{in}=1V_{p-p}, f=120Hz$	39	66	-	dB
Output Noise Voltage	$V_{NO}$	$V_{IN}=13V, BW=10Hz \sim 100kHz$ $I_o=40mA$	-	100	-	$\mu V$
<b>NJM78L08A</b>						
Output Voltage	$V_o$	$V_{IN}=14V, I_o=40mA$	7.6	8.0	8.4	V
Line Regulation1	$\Delta V_o-V_{IN1}$	$V_{IN}=10.5V \sim 23V, I_o=40mA$	-	-	225	mV
Line Regulation2	$\Delta V_o-V_{IN2}$	$V_{IN}=11V \sim 23V, I_o=40mA$	-	-	175	mV
Load Regulation1	$\Delta V_o-I_o1$	$V_{IN}=14V, I_o=1 \sim 40mA$	-	-	50	mV
Load Regulation2	$\Delta V_o-I_o2$	$V_{IN}=14V, I_o=1 \sim 100mA$	-	-	100	mV
Quiescent Current	$I_Q$	$V_{IN}=14V, I_o=0mA$	-	2.1	6	mA
Average Temperature	$\Delta V_o/\Delta T$	$V_{IN}=14V, I_o=1mA$	-	0.6	-	mV/°C
Coefficient of Output Voltage						
Ripple Rejection	RR	$11V < V_{IN} < 20V, I_o=40mA$ $e_{in}=1V_{p-p}, f=120Hz$	39	66	-	dB
Output Noise Voltage	$V_{NO}$	$V_{IN}=14V, BW=10Hz \sim 100kHz$ $I_o=40mA$	-	115	-	$\mu V$

(\*1):SOT-89 package only.

(\*2):TO-92 package only.

(\*3):SOT-89,TO-92, EMP8

■ ELECTRICAL CHARACTERISTICS( $C_{IN}=0.33\mu F, C_o=0.1\mu F, T_j=25^\circ C$ )  
 Measurement is to be conducted is pulse testing.

PARAMETER	SYMBOL	TEST CONDITION	MIN.	TYP.	MAX.	UNIT
<b>NJM78L09A(*3)</b>						
Output Voltage	$V_o$	$V_{IN}=15V, I_o=40mA$	8.55	9.0	9.45	V
Line Regulation1	$\Delta V_o-V_{IN1}$	$V_{IN}=11.5V \sim 23V, I_o=40mA$	-	-	250	mV
Line Regulation2	$\Delta V_o-V_{IN2}$	$V_{IN}=12V \sim 23V, I_o=40mA$	-	-	200	mV
Load Regulation1	$\Delta V_o-I_o1$	$V_{IN}=15V, I_o=1 \sim 40mA$	-	-	50	mV
Load Regulation2	$\Delta V_o-I_o2$	$V_{IN}=15V, I_o=1 \sim 100mA$	-	-	100	mV
Quiescent Current	$I_Q$	$V_{IN}=15V, I_o=0mA$	-	2.1	6	mA
Average Temperature	$\Delta V_o/\Delta T$	$V_{IN}=15V, I_o=1mA$	-	0.65	-	mV/°C
Coefficient of Output Voltage						
Ripple Rejection	RR	$12V < V_{IN} < 21V, I_o=40mA$ $e_{in}=1Vp-p, f=120Hz$	38	65	-	dB
Output Noise Voltage	$V_{NO}$	$V_{IN}=15V, BW=10Hz \sim 100kHz$ $I_o=40mA$	-	125	-	$\mu V$
<b>NJM78L10A</b>						
Output Voltage	$V_o$	$V_{IN}=16V, I_o=40mA$	9.5	10.0	10.5	V
Line Regulation1	$\Delta V_o-V_{IN1}$	$V_{IN}=13V \sim 25V, I_o=40mA$	-	-	250	mV
Line Regulation2	$\Delta V_o-V_{IN2}$	$V_{IN}=14V \sim 25V, I_o=40mA$	-	-	200	mV
Load Regulation1	$\Delta V_o-I_o1$	$V_{IN}=16V, I_o=1 \sim 40mA$	-	-	50	mV
Load Regulation2	$\Delta V_o-I_o2$	$V_{IN}=16V, I_o=1 \sim 100mA$	-	-	100	mV
Quiescent Current	$I_Q$	$V_{IN}=16V, I_o=0mA$	-	2.1	6	mA
Average Temperature	$\Delta V_o/\Delta T$	$V_{IN}=16V, I_o=1mA$	-	0.7	-	mV/°C
Coefficient of Output Voltage						
Ripple Rejection	RR	$13V < V_{IN} < 22V, I_o=40mA$ $e_{in}=1Vp-p, f=120Hz$	37	64	-	dB
Output Noise Voltage	$V_{NO}$	$V_{IN}=16V, BW=10Hz \sim 100kHz$ $I_o=40mA$	-	135	-	$\mu V$
<b>NJM78L12A(*3)</b>						
Output Voltage	$V_o$	$V_{IN}=19V, I_o=40mA$	11.4	12.0	12.6	V
Line Regulation1	$\Delta V_o-V_{IN1}$	$V_{IN}=14.5V \sim 27V, I_o=40mA$	-	-	250	mV
Line Regulation2	$\Delta V_o-V_{IN2}$	$V_{IN}=16V \sim 27V, I_o=40mA$	-	-	200	mV
Load Regulation1	$\Delta V_o-I_o1$	$V_{IN}=19V, I_o=1 \sim 40mA$	-	-	50	mV
Load Regulation2	$\Delta V_o-I_o2$	$V_{IN}=19V, I_o=1 \sim 100mA$	-	-	100	mV
Quiescent Current	$I_Q$	$V_{IN}=19V, I_o=0mA$	-	2.1	6.5	mA
Average Temperature	$\Delta V_o/\Delta T$	$V_{IN}=19V, I_o=1mA$	-	0.9	-	mV/°C
Coefficient of Output Voltage						
Ripple Rejection	RR	$15V < V_{IN} < 25V, I_o=40mA$ $e_{in}=1Vp-p, f=120Hz$	37	62	-	dB
Output Noise Voltage	$V_{NO}$	$V_{IN}=19V, BW=10Hz \sim 100kHz$ $I_o=40mA$	-	160	-	$\mu V$
<b>NJM78L15A</b>						
Output Voltage	$V_o$	$V_{IN}=23V, I_o=40mA$	14.3	15.0	15.7	V
Line Regulation1	$\Delta V_o-V_{IN1}$	$V_{IN}=17.5V \sim 30V, I_o=40mA$	-	-	300	mV
Line Regulation2	$\Delta V_o-V_{IN2}$	$V_{IN}=20V \sim 30V, I_o=40mA$	-	-	250	mV
Load Regulation1	$\Delta V_o-I_o1$	$V_{IN}=23V, I_o=1 \sim 40mA$	-	-	75	mV
Load Regulation2	$\Delta V_o-I_o2$	$V_{IN}=23V, I_o=1 \sim 100mA$	-	-	150	mV
Quiescent Current	$I_Q$	$V_{IN}=23V, I_o=0mA$	-	2.2	6.5	mA
Average Temperature	$\Delta V_o/\Delta T$	$V_{IN}=23V, I_o=1mA$	-	1.0	-	mV/°C
Coefficient of Output Voltage						
Ripple Rejection	RR	$18.5V < V_{IN} < 28.5V, I_o=40mA$ $e_{in}=1Vp-p, f=120Hz$	34	60	-	dB
Output Noise Voltage	$V_{NO}$	$V_{IN}=23V, BW=10Hz \sim 100kHz$ $I_o=40mA$	-	190	-	$\mu V$

(\*1):SOT-89 package only.

(\*2):TO-92 package only.

(\*3):SOT-89,TO-92, EMP8

■ ELECTRICAL CHARACTERISTICS( $C_{IN}=0.33\mu F, C_o=0.1\mu F, T_j=25^\circ C$ )  
 Measurement is to be conducted is pulse testing.

PARAMETER	SYMBOL	TEST CONDITION	MIN.	TYP.	MAX.	UNIT
<b>NJM78L18A</b>						
Output Voltage	$V_o$	$V_{IN}=27V, I_o=40mA$	17.1	18.0	18.9	V
Line Regulation1	$\Delta V_o-V_{IN1}$	$V_{IN}=22V \sim 33V, I_o=40mA$	-	-	320	mV
Line Regulation2	$\Delta V_o-V_{IN2}$	$V_{IN}=23V \sim 33V, I_o=40mA$	-	-	270	mV
Load Regulation1	$\Delta V_o-I_o1$	$V_{IN}=27V, I_o=1 \sim 40mA$	-	-	80	mV
Load Regulation2	$\Delta V_o-I_o2$	$V_{IN}=27V, I_o=1 \sim 100mA$	-	-	160	mV
Quiescent Current	$I_Q$	$V_{IN}=27V, I_o=0mA$	-	2.2	6.5	mA
Average Temperature	$\Delta V_o/\Delta T$	$V_{IN}=27V, I_o=1mA$	-	1.1	-	mV/°C
Coefficient of Output Voltage						
Ripple Rejection	RR	$23V < V_{IN} < 33V, I_o=40mA$ $e_{in}=1Vp-p, f=120Hz$	33	59	-	dB
Output Noise Voltage	$V_{NO}$	$V_{IN}=27V, BW=10Hz \sim 100kHz$ $I_o=40mA$	-	230	-	$\mu V$
<b>NJM78L20A</b>						
Output Voltage	$V_o$	$V_{IN}=29V, I_o=40mA$	19.0	20.0	21.0	V
Line Regulation1	$\Delta V_o-V_{IN1}$	$V_{IN}=23V \sim 34V, I_o=40mA$	-	-	330	mV
Line Regulation2	$\Delta V_o-V_{IN2}$	$V_{IN}=24V \sim 34V, I_o=40mA$	-	-	280	mV
Load Regulation1	$\Delta V_o-I_o1$	$V_{IN}=29V, I_o=1 \sim 40mA$	-	-	90	mV
Load Regulation2	$\Delta V_o-I_o2$	$V_{IN}=29V, I_o=1 \sim 100mA$	-	-	180	mV
Quiescent Current	$I_Q$	$V_{IN}=29V, I_o=0mA$	-	2.3	7	mA
Average Temperature	$\Delta V_o/\Delta T$	$V_{IN}=29V, I_o=1mA$	-	1.2	-	mV/°C
Coefficient of Output Voltage						
Ripple Rejection	RR	$24V < V_{IN} < 34V, I_o=40mA$ $e_{in}=1Vp-p, f=120Hz$	32	58	-	dB
Output Noise Voltage	$V_{NO}$	$V_{IN}=29V, BW=10Hz \sim 100kHz$ $I_o=40mA$	-	250	-	$\mu V$
<b>NJM78L24A</b>						
Output Voltage	$V_o$	$V_{IN}=33V, I_o=40mA$	22.8	24	25.2	V
Line Regulation1	$\Delta V_o-V_{IN1}$	$V_{IN}=27V \sim 38V, I_o=40mA$	-	-	350	mV
Line Regulation2	$\Delta V_o-V_{IN2}$	$V_{IN}=28V \sim 38V, I_o=40mA$	-	-	300	mV
Load Regulation1	$\Delta V_o-I_o1$	$V_{IN}=33V, I_o=1 \sim 40mA$	-	-	100	mV
Load Regulation2	$\Delta V_o-I_o2$	$V_{IN}=33V, I_o=1 \sim 100mA$	-	-	200	mV
Quiescent Current	$I_Q$	$V_{IN}=33V, I_o=0mA$	-	2.3	7	mA
Average Temperature	$\Delta V_o/\Delta T$	$V_{IN}=33V, I_o=1mA$	-	1.4	-	mV/°C
Coefficient of Output Voltage						
Ripple Rejection	RR	$27.5V < V_{IN} < 37.5V, I_o=40mA$ $e_{in}=1Vp-p, f=120Hz$	32	57	-	dB
Output Noise Voltage	$V_{NO}$	$V_{IN}=33V, BW=10Hz \sim 100kHz$ $I_o=40mA$	-	280	-	$\mu V$

(\*1):SOT-89 package only.  
 (\*2):TO-92 package only.  
 (\*3):SOT-89,TO-92, EMP8

■ SOT-89 MARK

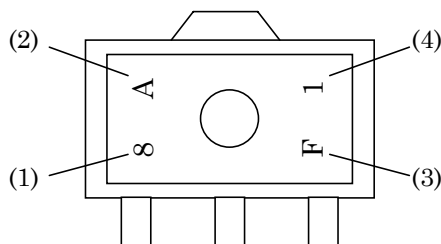

- (1) 8 : Positive Output
  - (2) Vo Rank
  - (3) The end of A.D.
  - (4) Production Mouth
- Oct. ... X  
 Nov. ... Y  
 Dec. ... Z

NJM78L02A	8	A
NJM78L03A	8	B
NJM78L05A	8	C
NJM78L06A	8	E
NJM78L62A	8	Z
NJM78L07A	8	F
NJM78L08A	8	G
NJM78L09A	8	H
NJM78L10A	8	J
NJM78L12A	8	K
NJM78L15A	8	L
NJM78L18A	8	M
NJM78L20A	8	N
NJM78L24A	8	P

# NJM78L00

## ■ TEST CIRCUIT

1. Output Voltage, Line Regulation, Load Regulation, Quiescent Current, Average Temperature Coefficient of Output Voltage, Output Noise Voltage, Peak Output/Short-Circuit Current
2. Ripple Rejection

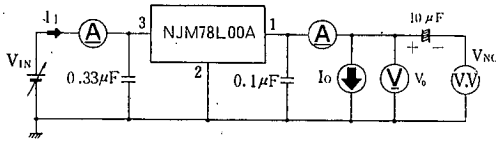

○ Measurement is to be conducted in pulse testing.  
 ○  $I_Q = I_1 - I_o$

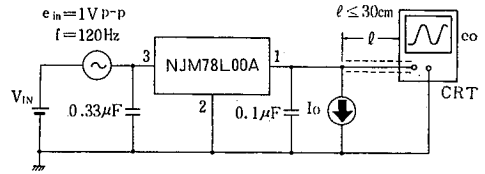

$$RR = 20 \log_{10} \left( \frac{e_{in}}{e_o} \right) \text{ (dB)}$$

## ■ AMBIENT TEMPERATURE VS. POWER DISSIPATION

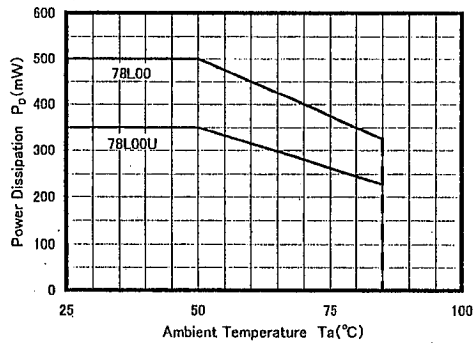

## ■ TYPICAL CHARACTERISTICS

**NJM78L05/L12/L24  
Output Characteristics**  
( $I_O = 0 \text{ mA}$ ,  $T_j = 25^\circ\text{C}$ )

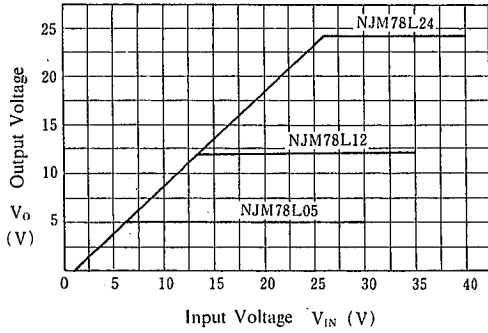

**NJM78L05 Dropout Characteristics**  
( $T_j = 25^\circ\text{C}$ )

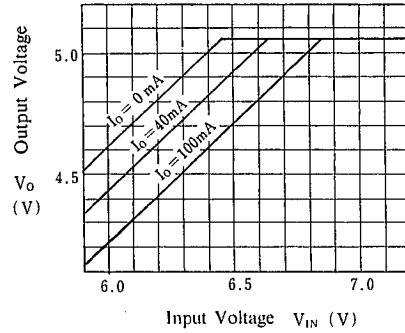

**NJM78L00 Series Short Circuit  
Output Current**  
( $T_j = 25^\circ\text{C}$ )

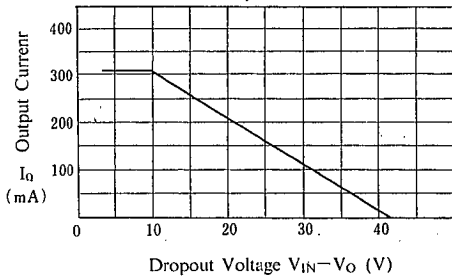

**NJM78L02/L24 Quiescent Current  
vs. Output Current**  
( $T_j = 25^\circ\text{C}$ )

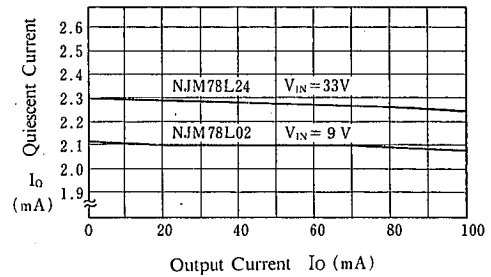

**NJM78L05 Quiescent Current  
vs. Input Voltage**  
( $I_O = 0 \text{ mA}$ ,  $T_j = 25^\circ\text{C}$ )

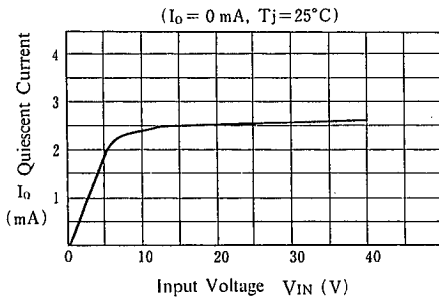

## ■ TYPICAL CHARACTERISTICS

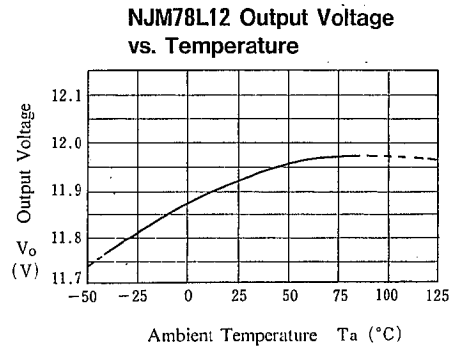
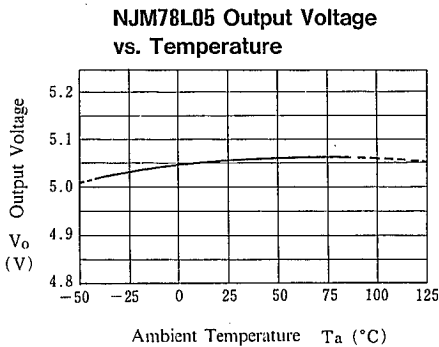
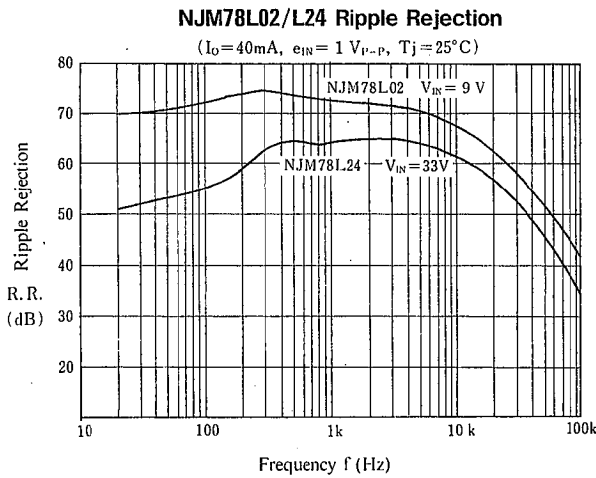
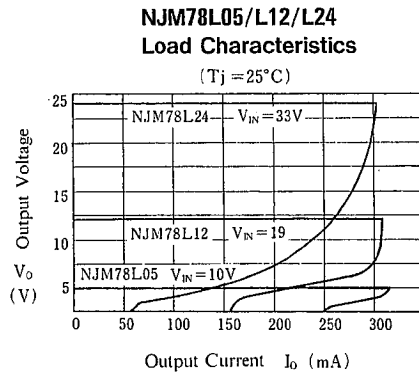
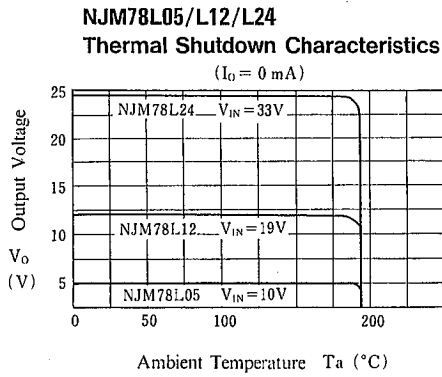

6



---

# MEMO

**[CAUTION]**

The specifications on this databook are only given for information, without any guarantee as regards either mistakes or omissions. The application circuits in this databook are described only to show representative usages of the product and not intended for the guarantee or permission of any right including the industrial rights.