

features

- RuO₂ thick film resistor element
- Anti-leaching nickel barrier terminations
- Meets or exceeds EIA 575, EIA PDP-100, MIL-R-55342F
- Marking: Three or four digits on indigo protective coat, 1E size: no marking, 1H: no marking, black protective coat
- Products with lead-free terminations meet EU RoHS requirements. Pb located in glass material, electrode and resistor element is exempt per Annex 1, exemption 5 of EU directive 2005/95/EC

dimensions and construction

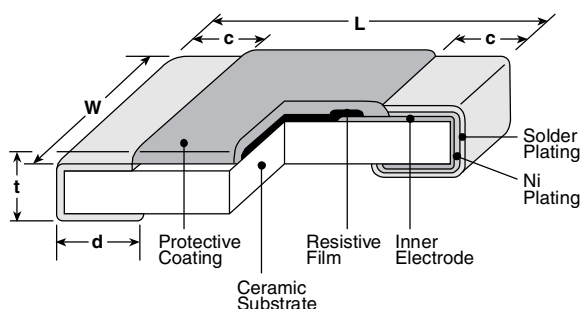

Type (Inch Size Code)	Dimensions inches (mm)				
	L	W	c	d	t
1H (0201)	.024±.001 (0.6±0.03)	.012±.001 (0.3±0.03)	.004±.002 (0.1±0.05)	.006±.002 (0.15±0.05)	.009±.001 (0.23±0.03)
1E (0402)	.039 ^{+0.04} _{-.002} (1.0 ^{+0.1} _{-.05})	.02 ^{+0.04} _{-.002} (0.5 ^{+0.1} _{-.05})	.01±.004 (0.25±0.1)	.01±.004 (0.25±0.1)	.014±.002 (0.35±0.05)
1J (0603)	.063±.008 (1.6±0.2)	.031 ^{+0.006} _{-.004} (0.8 ^{+0.15} _{-.01})	.014±.004 (0.35±0.1)	.014±.004 (0.35±0.1)	.018±.004 (0.45±0.1)
2A (0805)	.079±.008 (2.0±0.2)	.049±.004 (1.25±0.1)	.016±.008 (0.4±0.2)	.012 ^{+0.008} _{-.004} (0.3 ^{+0.2} _{-.01})	.02±.004 (0.5±0.1)
2B (1206)	.126±.008 (3.2±0.2)	.063±.008 (1.6±0.2)	.02±.012 (0.5±0.3)	.016 ^{+0.008} _{-.004} (0.4 ^{+0.2} _{-.01})	.024±.004 (0.6±0.1)
2E (1210)		.102±.008 (2.6±0.2)			
2H (2010)		.098±.008 (2.5±0.2)			
W2H (2010)	.197±.008 (5.0±0.2)			.026±.006 (0.65±0.15)	
3A (2512)	.248±.008 (6.3±0.2)	.122±.008 (3.1±0.2)		.016 ^{+0.008} _{-.004} (0.4 ^{+0.2} _{-.01})	
W3A (2512)					

ordering information

New Part #	SR73	2B	T	TD	1R00	F
Type		Size	Termination Material	Packaging	Nominal Resistance	Tolerance
		1H 1E 1J 2A 2B 2E 2H 3A W2H W3A	T: Sn (Other termination styles may be available, please contact factory for options) G: Au (2A: 0.1Ω - 10Ω - contact factory)	TCM: 0201 only: 7" 2mm pitch pressed paper TPL: 0402 only: 2mm pitch punch paper TP: 0402, 0603, 0805: 7" 2mm pitch punch paper TD: 0603, 0805, 1206, 1210: 7" 2mm pitch punched paper TDD: 0603, 0805, 1206, 1210: 10" paper tape TE: 0805, 1206, 1210, 2010 & 2512: 7" punched plastic TED: 0805, 1206, 1210, 2010 & 2512: 10" punched plastic For further information on packaging, please refer to Appendix A	±2%, ±5%: 2 significant figures + 1 multiplier "R" indicates decimal on value <10Ω ±1%: 3 significant figures + 1 multiplier "R" indicates decimal on value <100Ω All values less than 0.1Ω (100mΩ) are expressed in mΩ with "L" as decimal Example: 20mΩ = 20L0	D: ±0.5% F: ±1% G: ±2% J: ±5%

Specifications given herein may be changed at any time without prior notice. Please confirm technical specifications before you order and/or use.

12/01/08

applications and ratings

NEW	Part Designation*	Power Rating @ 70°C	T.C.R. (ppm/°C) Max.	Resistance Range**				Absolute Maximum Working Voltage	Maximum Overload Voltage (5 Secs. Max.)	Operating Temperature Range
				E-24, E-96 (D±0.5%)	E-24, E-96 (F±1%)	E-24 (G±2%)	E-24 (J±5%)			
	SR731H (0201)	0.1W	0~±400	—	1Ω - 10Ω	—	0.47Ω - 10Ω	1.0V	2.5V	-55°C to +125°C
	SR731E (0402)	1/8W (.125W) 1/6W (.166W')	±200	—	0.51Ω - 10Ω***	0.51Ω - 10Ω	0.51Ω - 10Ω	1.11V	2.79V	-55°C to +150°C
±300			—	0.2Ω - 0.47Ω***	0.2Ω - 0.47Ω	0.2Ω - 0.47Ω				
±500			—	0.1Ω - 0.18Ω***	0.1Ω - 0.18Ω	0.1Ω - 0.18Ω				
	SR731J (0603)	1/5W (.2W)	±200	—	0.1Ω - 10Ω	0.1Ω - 10Ω	0.1Ω - 10Ω	1.41V	3.53V	
	SR732A (0805)	1/4W (.25W) 1/3W (.33W')	±100	0.15Ω - 10Ω	0.1Ω - 10Ω	—	—	1.58V	3.95V	
±200			—	—	0.1Ω - 10Ω	—				
±500			—	—	—	0.051Ω - 0.091Ω				
±800			—	—	—	0.030Ω - 0.047Ω				
	SR732B (1206)	1/3W (.33W) 1/2W (.5W')	±100	0.15Ω - 10Ω	0.1Ω - 10Ω	—	—	1.81V	4.54V	
±200			—	—	0.1Ω - 10Ω	0.1Ω - 10Ω				
±500			—	—	—	0.056Ω - 0.091Ω				
±800			—	—	—	0.030Ω - 0.051Ω				
	SR732E (1210)	1/2W (.5W) 2/3W (.66W')	±100	—	0.1Ω - 10Ω	—	—	2.23V	5.59V	
±200			—	—	0.1Ω - 10Ω	0.047Ω - 10Ω				
±500			—	—	—	0.036Ω - 0.043Ω				
±1000			—	—	—	0.024Ω - 0.033Ω				
	SR732H/W2H (2010)	3/4W (.75W)	±100	—	0.1Ω - 10Ω	—	—	2.73V	6.84V	
±200			—	—	0.1Ω - 10Ω	0.1Ω - 10Ω				
±500			—	—	—	0.056Ω - 0.091Ω				
±800			—	—	—	0.033Ω - 0.051Ω				
	SR733A/W3A (2512)	1W	±100	—	0.1Ω - 10Ω	—	—	3.16V	7.90V	
±200			—	—	0.1Ω - 10Ω	0.1Ω - 10Ω				
±500			—	—	—	0.056Ω - 0.091Ω				
±800			—	—	—	0.039Ω - 0.051Ω				

* Parenthesis indicate EIA package size codes. ** See Appendix D for available decade values. *** 1H, 1E (F: ±1%) E-24 values only.

† Please contact factory for limitation of Surface Mount Temp. Rise

environmental applications

Derating Curve

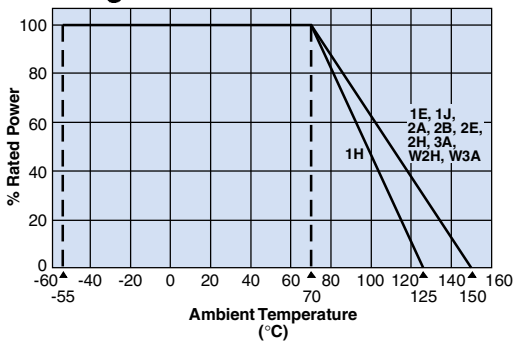

Surface Temperature Rise

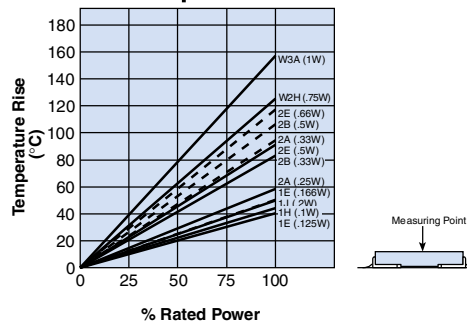

Performance Characteristics

Parameter	Requirement Δ R		Test Method
	Limit	Typical	
Resistance	Within specified tolerance	—	25°C
T.C.R.	Within specified T.C.R.	—	+25°C/-55°C and +25°C/+125°C
Overload (Short time)	±2%	±0.5%	Rated Voltage x 2.5 for 5 seconds
Resistance to Solder Heat	±3%*, ±1%**	±0.75%*, ±0.3%**	260°C ± 5°C, 10 seconds ± 1 second
Rapid Change of Temperature	±1%	±0.3%	-40°C (30 minutes), +125°C (30 minutes), 100 cycles
Moisture Resistance	±3%*, ±2%**	±1%	40°C ± 2°C, 90%-95% RH, 1000 hours, 1.5 hr ON, 0.5 hr OFF cycle
Endurance at 70°C	±3%*, ±2%**	±1%	70°C ± 2°C, 1000 hours, 1.5 hr ON, 0.5 hr OFF cycle
High Temperature Exposure	±1%	±0.3%	1H: +125°C, 1000 hours; 1E, 1J, 2A, 2B, 2E, W2H, W3A: +155°C, 1000 hours

* 1H

** 1E-W3A

Specifications given herein may be changed at any time without prior notice. Please confirm technical specifications before you order and/or use.

12/16/08