

DATA SHEET

LOW OHMIC CHIP RESISTORS

RL series

5%, 2%, 1%

sizes 0402/0603/0805/1206/

1210/1218/2010/2512

RoHS compliant



SCOPE

This specification describes RL0402 to RL2512 low ohmic chip resistors with lead-free terminations made by thick film process.

APPLICATIONS

- Converters
- Printer equipment
- Server board
- Telecom
- Consumer

FEATURES

- RoHS compliant
 - Products with lead free terminations meet RoHS requirements
 - Pb-glass contained in electrodes
 - Resistor element and glass are exempted by RoHS
- Reducing environmentally hazardous wastes
- High component and equipment reliability
- Saving of PCB space
- None forbidden-materials used in products/production
- Low resistances applied to current sensing
- Halogen Free Epoxy

ORDERING INFORMATION - GLOBAL PART NUMBER & I2NC

Both part numbers are identified by the series, size, tolerance, packing type, temperature coefficient, taping reel and resistance value.

YAGEO BRAND ordering code

GLOBAL PART NUMBER (PREFERRED)

RL XXXX X X X XX XXXX L
 (1) (2) (3) (4) (5) (6) (7)

(1) SIZE

0402 / 0603 / 0805 / 1206 / 1210 / 1218 / 2010 / 2512

(2) TOLERANCE

F = ±1%
 G = ±2%
 J = ±5%

(3) PACKAGING TYPE

R = Paper taping reel K = Embossed taping reel

(4) TEMPERATURE COEFFICIENT OF RESISTANCE

-- = Base on spec

(5) TAPING REEL

07 = 7 inch dia. Reel 10 = 10 inch dia. Reel 13 = 13 inch dia. Reel

(6) RESISTANCE VALUE

There are 2~4 digits indicated the resistor value. Letter R/K/M is decimal point, no need to mention the last zero after R/K/M, e.g.1K2, not 1K20.
 Detailed resistance rules show in table of "Resistance rule of global part number".

(7) OPTIONAL CODE

L = optional symbol (Note) H = Halogen / Lead free (special code on request)

| Resistance rule of global part number | |
|---------------------------------------|---|
| Resistance code rule | Example |
| 0RXXX (1 to 976 mΩ) | 0R1 = 0.1 Ω 0R12 = 0.12 Ω 0R105 = 0.105 Ω |
| XRXX (1 to 9.76 Ω) | 1R = 1 Ω 1R5 = 1.5 Ω 9R76 = 9.76 Ω |
| XXRX (10 to 97.6 Ω) | 10R = 10 Ω 97R6 = 97.6 Ω |
| XXXR (100 to 976 Ω) | 100R = 100 Ω |
| XKXX (1 to 9.76 KΩ) | 1K = 1,000 Ω 9K76 = 9760 Ω |
| XMXX (1 to 9.76 MΩ) | 1M = 1,000,000 Ω 9M76 = 9,760,000 Ω |

ORDERING EXAMPLE

The ordering code of a RL0603 chip resistor, value 0.56 Ω with ±1% tolerance, supplied in 7-inch tape reel is: RL0603FR-070R56 (L).

NOTE

1. All our RSMD products meet RoHS compliant. "LFP" of the internal 2D reel label mentions "Lead Free Process"
2. On customized label, "LFP" or specific symbol printed and the optional "L" at the end of GLOBAL PART NUMBER / I2NC can be added (both are on customer request)
3. Comply Halogen Free Epoxy

PHYCOMP BRAND ordering codes

Both GLOBAL PART NUMBER (preferred) and I2NC (traditional) codes are acceptable to order Phycomp brand products.

GLOBAL PART NUMBER (PREFERRED)

For detailed information of GLOBAL PART NUMBER and ordering example, please refer to page 2.

I2NC CODE

2350 / 2390 / 2322 XXX XXXXX **L**
 (1) (2) (3) (4)

| SIZE | TYPE | START IN ⁽¹⁾ | TOL. (%) | RESISTANCE RANGE | EMBOSSED ⁽²⁾ TAPE ON REEL | | PAPER/PE ⁽²⁾ TAPE ON REEL (units) |
|------|---------|-------------------------|----------|------------------|--------------------------------------|-------|--|
| | | | | | 4,000 | 5,000 | |
| 0402 | LRC31 | 2350 | ±5% | 0.05 to 1 Ω | - | - | 513 20xxx |
| | LRC32 | 2350 | ±1% | 0.05 to 1 Ω | - | - | 513 22xxx |
| 0603 | LRC21 | 2350 | ±5% | 0.01 to 1 Ω | - | - | 512 10xxx |
| | LRC22 | 2350 | ±1% | 0.01 to 1 Ω | - | - | 512 12xxx |
| 0805 | LRC11 | 2350 | ±5% | 0.01 to 1 Ω | - | - | 511 10xxx |
| | LRC12 | 2350 | ±1% | 0.01 to 1 Ω | - | - | 511 12xxx |
| 1206 | LRC01 | 2350 | ±5% | 0.01 to 1 Ω | - | - | 510 10xxx |
| | LRC02 | 2350 | ±1% | 0.01 to 1 Ω | - | - | 510 12xxx |
| 1210 | LPRC101 | 2390 | ±5% | 0.01 to 0.0976 Ω | - | - | 735 90xxx |
| | LPRC101 | 2390 | ±5% | 0.1 to 1 Ω | - | - | 735 60xxx |
| | LPRC102 | 2390 | ±1% | 0.01 to 1 Ω | - | - | 735 3xxxx |
| 1218 | LPRC201 | 2322 | ±5% | 0.01 to 1 Ω | 735 | 64xxx | - |
| | LPRC201 | 2322 | ±1% | 0.01 to 1 Ω | 735 | 7xxxx | - |
| 2010 | LPRC111 | 2322 | ±5% | 0.01 to 0.0976 Ω | 760 | 90xxx | - |
| | LPRC111 | 2322 | ±5% | 0.1 to 1 Ω | 760 | 60xxx | - |
| | LPRC111 | 2322 | ±1% | 0.01 to 0.0976 Ω | 761 | 90xxx | - |
| | LPRC111 | 2322 | ±1% | 0.1 to 1 Ω | 761 | 6xxxx | - |
| 2512 | LPRC221 | 2322 | ±5% | 0.01 to 0.0976 Ω | 762 | 90xxx | - |
| | LPRC221 | 2322 | ±5% | 0.1 to 1 Ω | 762 | 60xxx | - |
| | LPRC221 | 2322 | ±1% | 0.01 to 0.0976 Ω | 763 | 90xxx | - |
| | LPRC221 | 2322 | ±1% | 0.1 to 1 Ω | 763 | 6xxxx | - |

| Resistance decade ⁽³⁾ | Last digit |
|----------------------------------|------------|
| 0.01 to 0.0976 Ω | 0 |
| 0.1 to 0.976 Ω | 7 |
| 1 to 9.76 Ω | 8 |
| 10 to 97.6 Ω | 9 |
| 100 to 976 Ω | 1 |
| 1 to 9.76 kΩ | 2 |
| 10 to 97.6 kΩ | 3 |
| 100 to 976 kΩ | 4 |
| 1 to 9.76 MΩ | 5 |
| 10 to 97.6 MΩ | 6 |

Example: 0.02 Ω = 0200 or 200
 0.3 Ω = 3007 or 307
 1 Ω = 1008 or 108
 33 kΩ = 3303 or 333
 10 MΩ = 1006 or 106

ORDERING EXAMPLE

The ordering code of a RL0603 chip resistor, value 0.56 Ω with ±1% tolerance, supplied in tape of 5,000 units per reel is: 2350512125609(L) or RL0603FR-070R56(L).

NOTE

- All our RSMD products are RoHS compliant. "LFP" of the internal 2D reel label mentions "Lead Free Process"
- On customized label, "LFP" or specific symbol printed and the optional "L" at the end of GLOBAL PART NUMBER / I2NC can be added (both are on customer request)
- Comply Halogen Free Epoxy

- The resistors have a 12-digit ordering code starting with 2350/2390/2322.
- The subsequent 4 or 5 digits indicate the resistor tolerance and packaging. (In I2NC code, only 07" tape reel code is supplied. Supply of 10"/13" tape reel is requested in Global part number ordering code.)
- The remaining 4 or 3 digits represent the resistance value with the last digit indicating the multiplier as shown in the table of "Last digit of I2NC".
- "L" is optional symbol ^(Note).
 "H" is Halogen / Lead free (special code on request).

MARKING

RL0805 / RL1206 / RL1210 / RL1218 / RL2010 / RL2512



E-24 series / Non-series (R= 25/40/50/60/250/400/500 mΩ): 4 digits
The “R” is used as a decimal point; the other 3 digits are significant.

RL0603: R≥100 mΩ IN E-24 SERIES, R = 10/20/30/40/50/60 mΩ

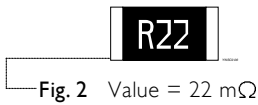

3 digits
The “R” is used as a decimal point; the other 2 digits are significant.

RL0402 / RL0603: R<100 mΩ EXCEPT 10/20/30/40/50/60 mΩ



No marking

For further marking information, please see special data sheet “Chip resistors marking”.

CONSTRUCTION

The resistors are constructed out of a high-grade ceramic body. Internal metal electrodes are added at each end and connected by a resistive paste. The composition of the paste is adjusted to give the approximate required resistance and laser cutting of this resistive layer that achieves tolerance trims the value. The resistive layer is covered with a protective coat and printed with the resistance value. Finally, the two external terminations (matte tin) are added. See fig. 4.

DIMENSIONS

Table I For outlines see fig. 4

| TYPE | L (mm) | W (mm) | H (mm) | l ₁ (mm) | l ₂ (mm) |
|--------|------------|------------|------------|---------------------|---------------------|
| RL0402 | 1.00 ±0.10 | 0.50 ±0.05 | 0.35 ±0.05 | 0.20 ±0.10 | 0.25 ±0.10 |
| RL0603 | 1.60 ±0.10 | 0.80 ±0.10 | 0.45 ±0.10 | 0.25 ±0.15 | 0.25 ±0.15 |
| RL0805 | 2.00 ±0.10 | 1.25 ±0.10 | 0.50 ±0.10 | 0.35 ±0.20 | 0.35 ±0.20 |
| RL1206 | 3.10 ±0.10 | 1.60 ±0.10 | 0.55 ±0.10 | 0.45 ±0.20 | 0.40 ±0.20 |
| RL1210 | 3.10 ±0.10 | 2.60 ±0.15 | 0.55 ±0.10 | 0.50 ±0.20 | 0.50 ±0.20 |
| RL1218 | 3.05 ±0.15 | 4.60 ±0.20 | 0.55 ±0.10 | 0.45 ±0.25 | 0.50 ±0.25 |
| RL2010 | 5.00 ±0.10 | 2.50 ±0.15 | 0.55 ±0.10 | 0.60 ±0.20 | 0.50 ±0.20 |
| RL2512 | 6.35 ±0.10 | 3.20 ±0.15 | 0.55 ±0.10 | 0.60 ±0.20 | 0.50 ±0.20 |

OUTLINES

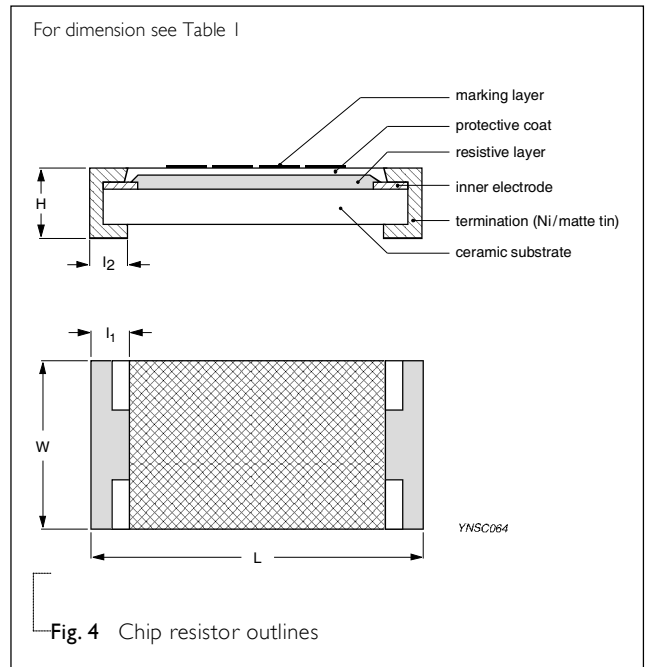

Fig. 4 Chip resistor outlines

ELECTRICAL CHARACTERISTICS

Table 2

| TYPE / RESISTANCE RANGE | TEMPERATURE COEFFICIENT OF RESISTANCE | | | | | | |
|-------------------------|---------------------------------------|---------------|---------------|---------------|---------------|-------------|-------------|
| | 50mΩ≤R<1Ω | | | | | | |
| RL0402 50mΩ≤R<1Ω | ±800 ppm/°C | | | | | | |
| RL0603 10mΩ≤R<1Ω | 10mΩ≤R≤36mΩ | 36mΩ<R≤91mΩ | 91mΩ<R≤500mΩ | 500mΩ<R<1Ω | | | |
| | ±1,500 ppm/°C | ±1,200 ppm/°C | ±800 ppm/°C | ±300 ppm/°C | | | |
| RL0805 | 10mΩ≤R≤18mΩ | 18mΩ<R≤47mΩ | 47mΩ<R≤91mΩ | 91mΩ<R≤360mΩ | 360mΩ<R≤500mΩ | 500mΩ<R<1Ω | |
| | ±1,500 ppm/°C | ±1,200 ppm/°C | ±1,000 ppm/°C | ±600 ppm/°C | ±300 ppm/°C | ±200 ppm/°C | |
| RL1206 | 10mΩ≤R<1Ω | ±1,500 ppm/°C | ±1,200 ppm/°C | ±1,000 ppm/°C | ±600 ppm/°C | ±300 ppm/°C | ±200 ppm/°C |
| RL1210 | | ±1,500 ppm/°C | ±1,000 ppm/°C | ±800 ppm/°C | ±600 ppm/°C | ±300 ppm/°C | ±200 ppm/°C |
| RL2010 | | ±1,500 ppm/°C | ±1,200 ppm/°C | ±1,000 ppm/°C | ±600 ppm/°C | ±300 ppm/°C | ±200 ppm/°C |
| RL2512 | ±1,500 ppm/°C | ±1,200 ppm/°C | ±800 ppm/°C | ±600 ppm/°C | ±300 ppm/°C | ±200 ppm/°C | |
| RL1218 10mΩ≤R<1Ω | 10mΩ≤R≤30mΩ | 30mΩ<R≤56mΩ | 56mΩ<R≤180mΩ | 180mΩ<R<1Ω | | | |
| | ±2,000 ppm/°C | ±1,000 ppm/°C | ±700 ppm/°C | ±250 ppm/°C | | | |

FOOTPRINT AND SOLDERING PROFILES

For recommended footprint and soldering profiles, please see the special data sheet “Chip resistors mounting”.

PACKING STYLE AND PACKAGING QUANTITY

Table 3 Packing style and packaging quantity

| PACKING STYLE | REEL DIMENSION | RL0402 | RL0603 | RL0805 | RL1206 | RL1210 | RL1218 | RL2010 | RL2512 |
|--------------------------|----------------|--------|--------|--------|--------|--------|--------|--------|--------|
| Paper taping reel (R) | 7" (178 mm) | 10,000 | 5,000 | 5,000 | 5,000 | 5,000 | --- | --- | --- |
| | 10" (254 mm) | 20,000 | 10,000 | 10,000 | 10,000 | 10,000 | --- | --- | --- |
| | 13" (330 mm) | 50,000 | 20,000 | 20,000 | 20,000 | 20,000 | --- | --- | --- |
| Embossed taping reel (K) | 7" (178 mm) | --- | --- | --- | --- | --- | 4,000 | 4,000 | 4,000 |

NOTE

1. For paper/embossed tape and reel specification/dimensions, please see the special data sheet “Chip resistors packing”.

FUNCTIONAL DESCRIPTION

OPERATING TEMPERATURE RANGE

Range: -55 °C to +125 °C

POWER RATING

Each type rated power at 70 °C:

RL0402=1/16 W; RL0603=1/10 W; RL0805=1/8 W;
 RL1206=1/4 W; RL1210=1/2 W; RL1218=1 W;
 RL2010=3/4 W; RL2512=1 W.

RATED VOLTAGE

The DC or AC (rms) continuous working voltage corresponding to the rated power is determined by the following formula:

$$V = \sqrt{P \times R}$$

Where

V = Continuous rated DC or AC (rms) working voltage (V)

P = Rated power (W)

R = Resistance value (Ω)

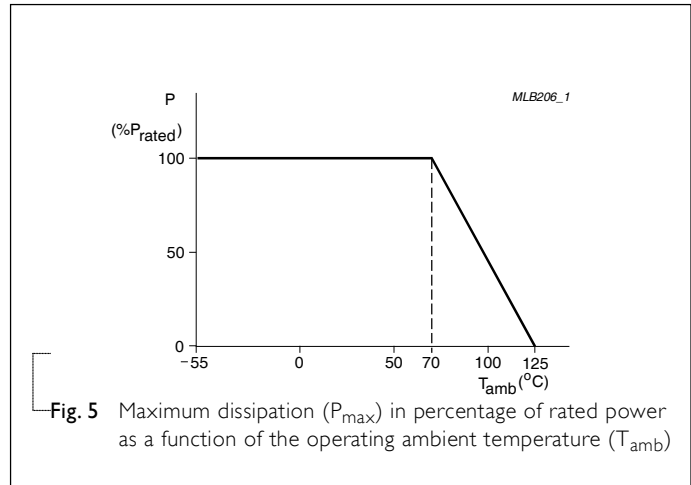

TESTS AND REQUIREMENTS
Table 4 Test condition, procedure and requirements

| TEST | TEST METHOD | PROCEDURE | REQUIREMENTS |
|---|--|---|--------------------------|
| Life/ Operational Life/ Endurance | MIL-STD-202G-method 108A | 1,000 hours at 70±5 °C applied RCWV | ±2% |
| | IEC 60115-1 4.25.1 | 1.5 hours on, 0.5 hour off, still air required | |
| | JIS C 5202-7.10 | | |
| High Temperature Exposure/ Endurance at upper category temperature | MIL-STD-202G-method 108A | 1,000 hours at maximum operating temperature | ±1% |
| | IEC 60115-1 4.25.3 | depending on specification, unpowered | |
| | JIS C 5202-7.11 | No direct impingement of forced air to the parts Tolerances: 125±3 °C | |
| Moisture Resistance | MIL-STD-202G-method 106F | Each temperature / humidity cycle is defined at 8 hours (method 106F), 3 cycles / 24 hours for 10d with 25 °C / 65 °C 95% R.H, without steps 7a & 7b, unpowered Parts mounted on test-boards, without condensation on parts Measurement at 24±2 hours after test conclusion | ±2% |
| | IEC 60115-1 4.24.2 | | |
| Thermal Shock | MIL-STD-202G-method 107G | -55/+125 °C Note: Number of cycles required is 300. Devices unmounted Maximum transfer time is 20 seconds. Dwell time is 15 minutes. Air – Air | ±1% |
| Short time overload | MIL-R-55342D-para 4.7.5 IEC60115-1 4.13 | 2.5 times RCWV or maximum overload voltage whichever is less for 5 sec at room temperature | ±2% No visible damage |
| Board Flex/ Bending | IEC60115-1 4.33 | Device mounted on PCB test board as described, only 1 board bending required 3 mm bending Bending time: 60±5 seconds Ohmic value checked during bending | ±1% No visible damage |

| TEST | TEST METHOD | PROCEDURE | REQUIREMENTS |
|-----------------------------------|--|--|---|
| Solderability - Wetting | IPC/JEDECJ-STD-002B test B IEC 60068-2-58 | Electrical Test not required Magnification 50X SMD conditions: 1 st step: method B, aging 4 hours at 155 °C dry heat 2 nd step: leadfree solder bath at 245±3 °C Dipping time: 3±0.5 seconds | Well tinned (≥95% covered) No visible damage |
| - Leaching | IPC/JEDECJ-STD-002B test D IEC 60068-2-58 | Leadfree solder, 260 °C, 30 seconds immersion time | No visible damage |
| - Resistance to Soldering Heat | MIL-STD-202G-method 210F IEC 60068-2-58 | Condition B, no pre-heat of samples. Leadfree solder, 270 °C, 10 seconds immersion time Procedure 2 for SMD: devices fluxed and cleaned with isopropanol | ±1% No visible damage |

REVISION HISTORY

| REVISION | DATE | CHANGE NOTIFICATION | DESCRIPTION |
|-----------|---------------|---------------------|---|
| Version 4 | Dec 11, 2008 | - | - Halogen Free Epoxy - Update global part number definition |
| Version 3 | Aug 07, 2008 | - | - Change to dual brand datasheet that describe RL0402 to RL2512 with RoHS compliant - Define global part number |
| Version 2 | Jul 15, 2005 | - | - Ordering example revised |
| Version 1 | Apr 15, 2005 | - | - Size 1218 extended - Test method and procedure updated - PE tape added (paper tape will be replaced by PE tape) |
| Version 0 | Nov. 10, 2003 | - | - First issue of this specification |

“Yageo reserves all the rights for revising the content of this datasheet without further notification, as long as the products itself are unchanged. Any product change will be announced by PCN.”