

ISA-PLAN® - SMD Präzisionswiderstände / SMD precision resistors

TECHNISCHE DATEN / TECHNICAL DATA		
Widerstandswerte	Resistance values	10 mOhm - 4.7 Ohm
Toleranz	Tolerance	0.5 % (≥ 50 mOhm), 1 %, 5 %
Temperaturkoeffizient(MANGANIN®)	Temperature coefficient (tcr)	< ±50 ppm/K (20 °C to 60 °C)
Temperaturbereich	Applicable temperature range	-55 °C to +140 °C
Belastbarkeit	Load capacity	3 W
Innerer Wärmewiderstand (R _{thi})	Internal heat resistance (R _{thi})	< 15 K/W
Isolationsspannung	Dielectric withstanding voltage	1000 VAC
Induktivität	Inductance	< 10 nH
Stabilität (Nennlast) Abweichung T _K = Kontaktstellentemperatur Stability (nominal load) deviation T _K = terminal temperature		< 0.5 % nach/after 2000 h (T _K = 80 °C)

MERKMALE / FEATURES

- 3 Watt Dauerleistung
- 3 Watt permanent power
- Dauerströme bis 17 A (10 mOhm)
- Continuous current load up to 17 Amps(10 mOhm)
- Standard-Lötpadgeometrie (Baugröße 4723)
- Standard pad size (size 4723)
- sehr hohe Pulsbelastbarkeit
- High pulse power rating
- Bauteilemontage: Reflow-, IR-Löten und Wellenlöten
- Mounting: reflow-, infrared soldering and wave soldering



Bauform/Size 4723

APPLIKATIONEN / APPLICATION

- Messwiderstand für Leistungshybride
- Current sensor for power hybrid applications
- Steuergeräte in der Automobiltechnik
- Control systems for the automotive market
- Leistungsmodulare
- Power modules
- Schaltnetzteile
- Switch mode power supplies

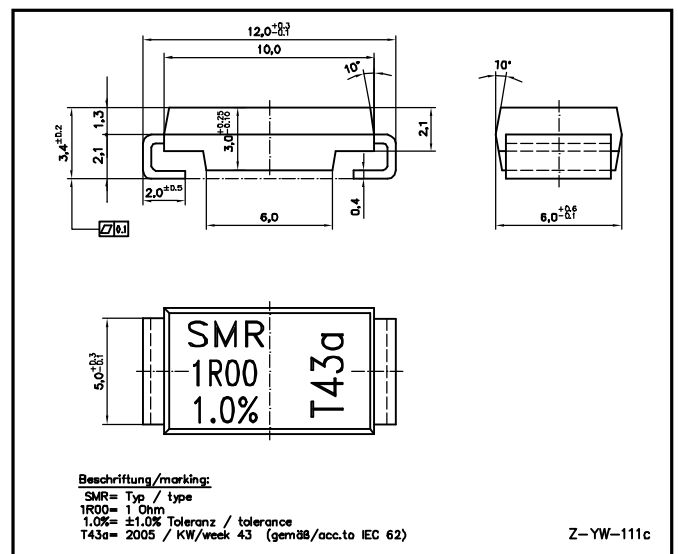



TK, Lastminderung und Langzeitstabilität / TCR, power derating and long term stability

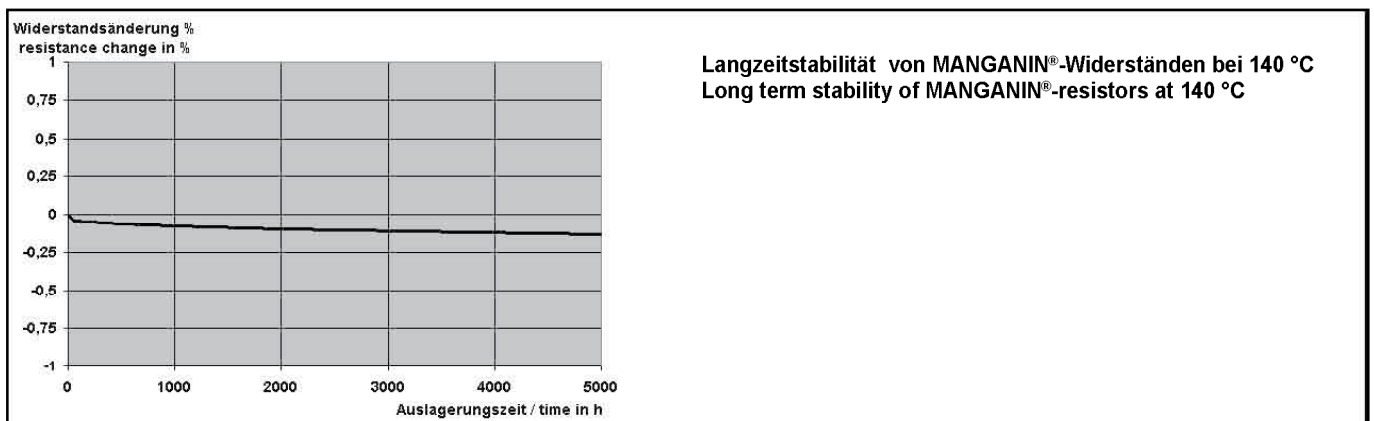
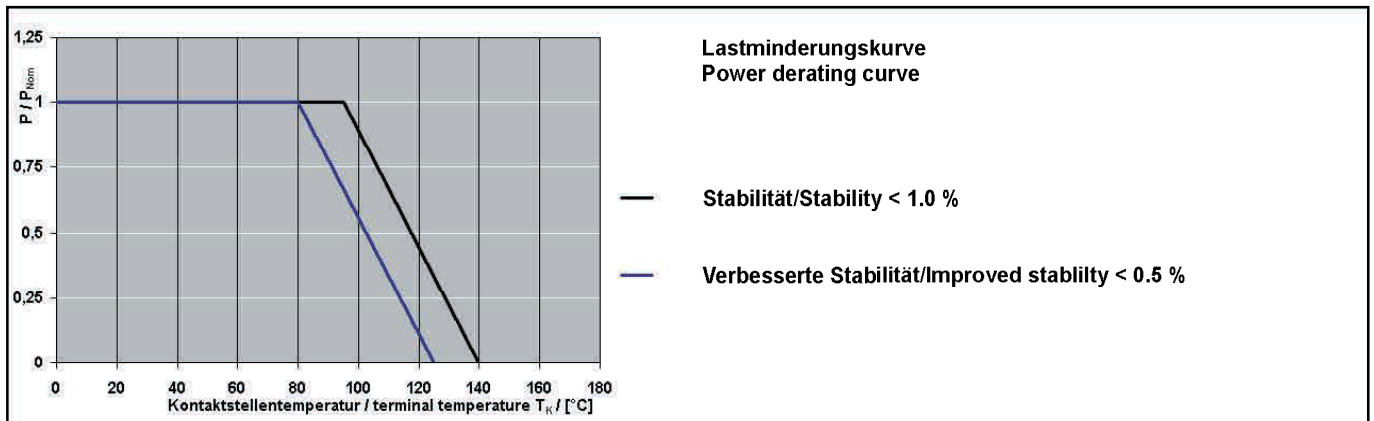
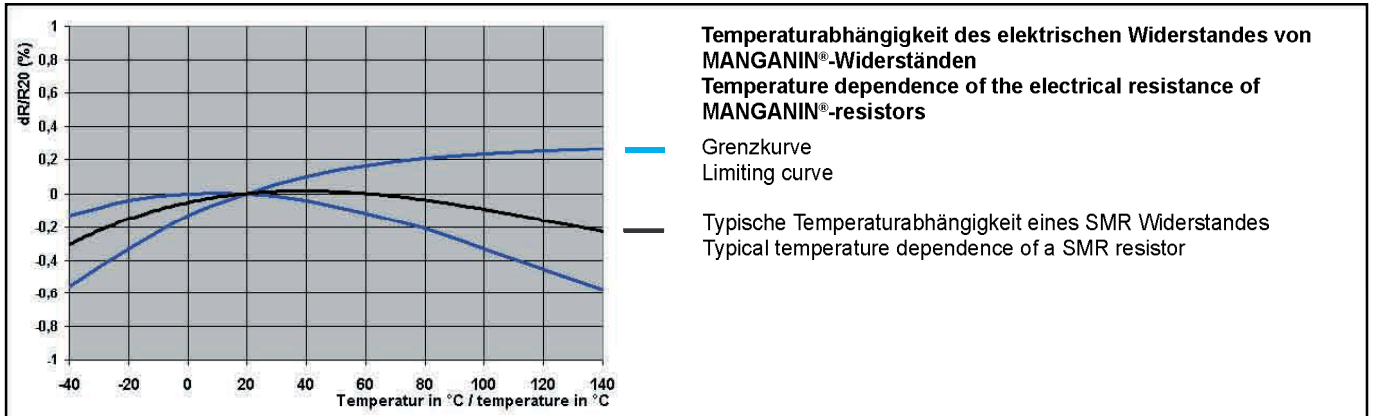

Vorschlag für Leiterplatten Layout (Reflowlöten)
Proposal for pcb-layout (reflow soldering)

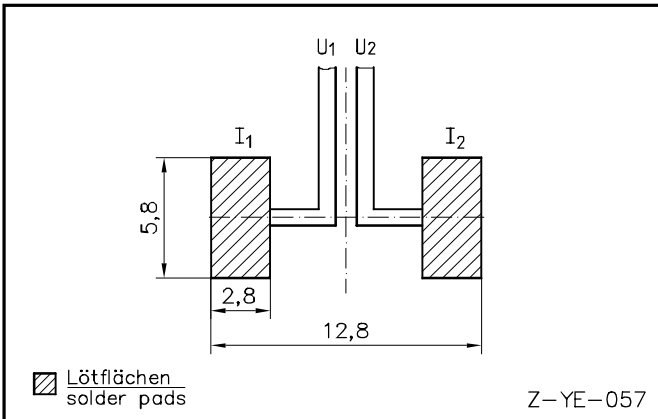

Lötprofil Vorschlag / Recommended solder profile			
Reflow-, Wellen und IR-löten, Reflow, wave and infrared soldering			
Temperatur	260 °C	255 °C	217 °C
Zeit (s)	peak	40	90
RoHS 2002/95/EG konform seit 01.01.2005. Ausführliche Informationen erhalten Sie auf unserer Homepage: www.isabellenhuette.de			
RoHS 2002/95/EC compliance since 01.01.2005. For more information please visit our website: www.isabellenhuette.de			

GURTINFORMATIONEN TAPE & REEL INFORMATION		
Norm / Specification	DIN EN 60286-3	
Gurtbreite / Tape width	24 mm	
Anzahl Bauteile/Parts per reel	1500	
BESTELLBEZEICHNUNG / ORDERING CODE		
SMR-R010-1.0		
Typ	Widerstandswert	Toleranz
Type	Resistance value	Tolerance
SMR	10 mOhm	1.0 %

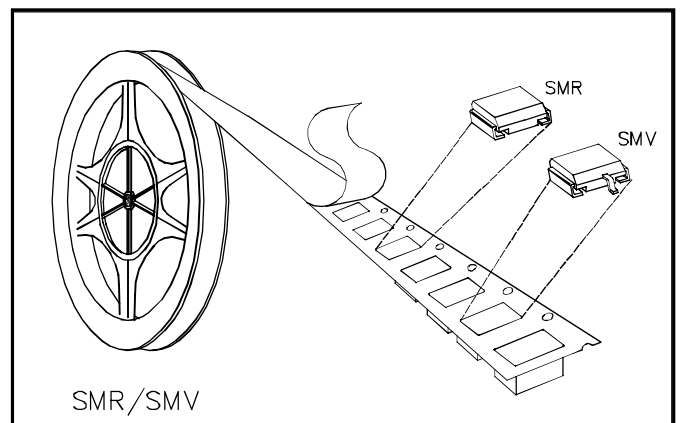

Gewährleistung

Alle Angaben über Eignung, Verarbeitung und Anwendung unserer Produkte, technische Beratung und sonstige Angaben erfolgen nach bestem Wissen, befreien den Käufer jedoch nicht von eigenen Prüfungen und Versuchen.

Warranty

All information regarding the suitable, workability and applicability of our products, all technical advice and other information are provided to the best of our knowledge and belief, but shall not discharge the buyer from his own examinations and tests.

Grenzkurve für maximale Pulsenergie bzw. Pulsleistung für Dauerbetrieb
Maximum puls energy resp. pulse power for continuous operation

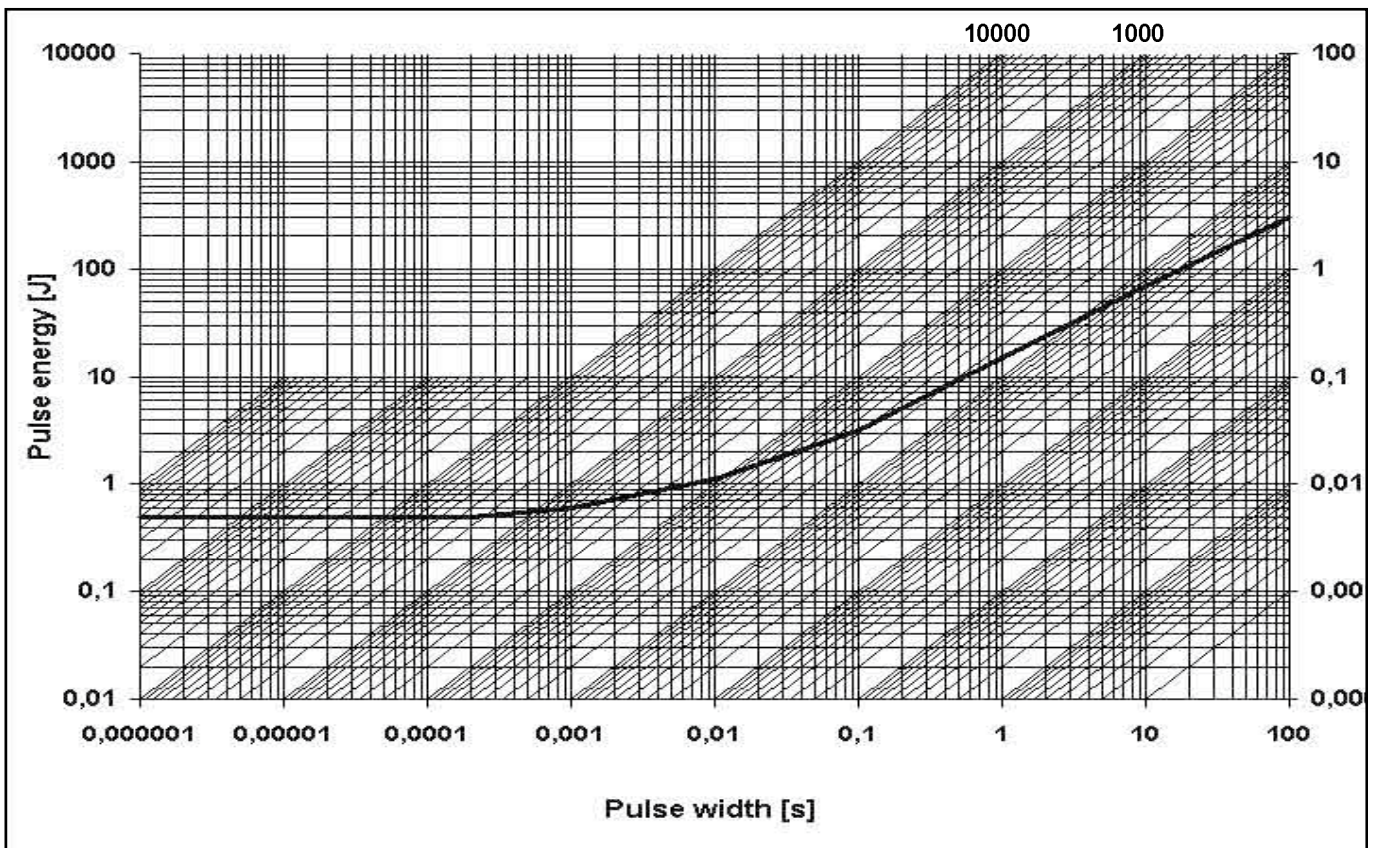

Die dargestellte Kurve gilt für den Widerstandswert R010. Für andere Werte kann die Kurve im unteren Bereich ggf. anders verlaufen, so dass in Grenzbereichen eine separate Qualifikation erfolgen sollte.

This curve is only valid for the resistance value R010. The shape of the curve in the range below 0.1 sec will be different for other resistance values. Therefore a separate qualification should be made for pulse power close to the above curve.

MIL. - STANDARD		
Parameters	Test Conditions	Specification
Maximum Temperature for full power operation	80 °C	80 °C
Working Temperature	-55 to 140 °C	-55 to 140 °C
Thermal Shock	MIL-STD-202 method 107E-B1	0.1 %
Overload	MIL-R-26E (5 times rated power, 5 sec)	0.2 %
Solderability	MIL-STD-202 method 208	> 95 % coverage
Resistance to Solvents	MIL-STD-202 method 215A, 2.1a, 2.1d	no damage
Low Temperature Storage and Operation	MIL-STD-26E	0.1 %
Terminal Strength	MIL-STD-202 method 211A	50N, 0.02 %
Resistance to Soldering Heat	MIL-STD-202 method 210B	0.1 %
Moisture Resistance	MIL-STD-202 method 106	0.1 %
Shock	MIL-STD-202 method 213B-A	0.2 %
Vibration, High Frequency	MIL-STD-202 method 204D-B	0.2 %
Life	MIL-STD-26E	0.2 %
Storage Life at Elevated Temperature	MIL-STD-202 method 108A-F	0.3 %
High Temperature Exposure	140 °C, 2000 h	0.2%
Current Noise	MIL-STD-202 method 308	0.01 %
Voltage Coefficient (%/V)	MIL-STD-202 method 309	linearity error less than 120dB
Resistance Temperature Characteristic	MIL-STD-202 method 304 (20-60°C)	<50 ppm/K
Thermal EMF	0 - 100 °C	2 µV/ °C max.
Frequency Characteristic	inductivity	< 10 nH