

74LS138, S138 Decoders/Demultiplexers

1-Of-8 Decoder/Demultiplexer
Product Specification

Logic Products

FEATURES

- Demultiplexing capability
- Multiple input enable for easy expansion
- Ideal for memory chip select decoding
- Direct replacement for Intel 3205

DESCRIPTION

The '138 decoder accepts three binary weighted inputs (A_0, A_1, A_2) and when enabled, provides eight mutually exclusive, active LOW outputs ($\bar{O}_0 - \bar{O}_7$). The device features three Enable Inputs: two active LOW (\bar{E}_1, \bar{E}_2) and one active HIGH (E_3). Every output will be HIGH unless \bar{E}_1 and \bar{E}_2 are LOW and E_3 is HIGH. This multiple enable function allows easy parallel expansion of the device to a 1-of-32 (5 lines to 32 lines) decoder with just four '138s and one inverter.

The device can be used as an eight output demultiplexer by using one of the active LOW Enable inputs as the Data input and the remaining Enable inputs as strobes. Enable inputs not used must be permanently tied to their appropriate active HIGH or active LOW state.

TYPE	TYPICAL PROPAGATION DELAY	TYPICAL SUPPLY CURRENT (TOTAL)
74LS138	20ns	6.3mA
74S138	7ns	49mA

ORDERING CODE

PACKAGES	COMMERCIAL RANGE $V_{CC} = 5V \pm 5\%$; $T_A = 0^\circ C$ to $+70^\circ C$
Plastic DIP	N74S138N, N74LS138N
Plastic SO	N74LS138D, N74S138D

NOTE:

For information regarding devices processed to Military Specifications see the Signetics Military Products Data Manual.

INPUT AND OUTPUT LOADING AND FAN-OUT TABLE

PINS	DESCRIPTION	74S	74LS
All	Inputs	1Sul	1LSul
All	Outputs	10Sul	10LSul

NOTE:

Where a 74S unit load (Sul) is $50\mu A I_{IH}$ and $-2.0mA I_{IL}$, and a 74LS unit load (LSul) is $20\mu A I_{IH}$ and $-0.4mA I_{IL}$.

PIN CONFIGURATION

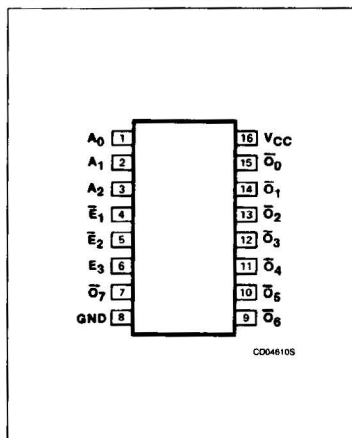

LOGIC SYMBOL

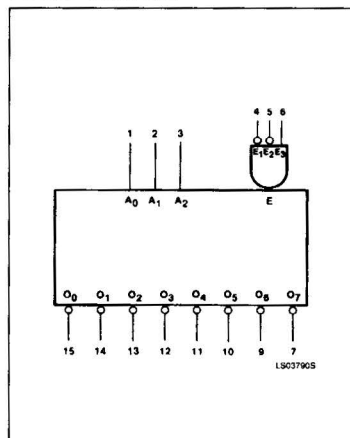

LOGIC SYMBOL (IEEE/IEC)

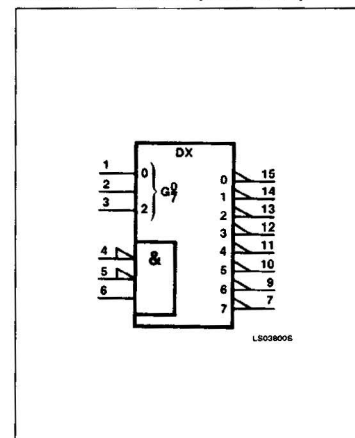

Decoders/Demultiplexers

74LS138, S138

LOGIC DIAGRAM

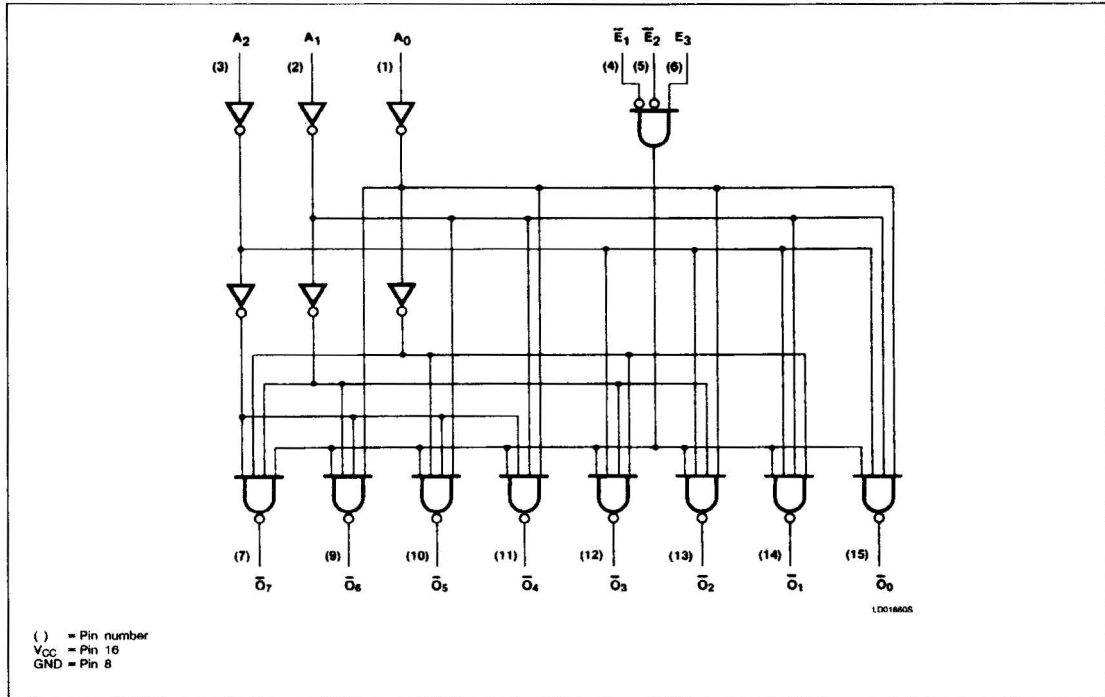

FUNCTION TABLE

INPUTS						OUTPUTS							
\bar{E}_1	\bar{E}_2	E_3	A_0	A_1	A_2	$\bar{0}$	$\bar{1}$	$\bar{2}$	$\bar{3}$	$\bar{4}$	$\bar{5}$	$\bar{6}$	$\bar{7}$
H	X	X	X	X	X	H	H	H	H	H	H	H	H
X	H	X	X	X	X	H	H	H	H	H	H	H	H
X	X	L	X	X	X	H	H	H	H	H	H	H	H
L	L	H	L	L	L	L	H	H	H	H	H	H	H
L	L	H	H	L	L	H	L	H	H	H	H	H	H
L	L	H	L	H	L	H	H	L	H	H	H	H	H
L	L	H	H	H	L	H	H	H	L	H	H	H	H
L	L	H	H	L	H	H	H	H	H	L	H	H	H
L	L	H	L	H	H	H	H	H	H	H	L	H	H
L	L	H	H	H	H	H	H	H	H	H	H	L	L

H = HIGH voltage level
 L = LOW voltage level
 X = Don't care

Decoders/Demultiplexers

74LS138, S138

ABSOLUTE MAXIMUM RATINGS (Over operating free-air temperature range unless otherwise noted.)

PARAMETER	74LS	74S	UNIT
V _{CC} Supply voltage	7.0	7.0	V
V _{IN} Input voltage	-0.5 to +7.0	-0.5 to +5.5	V
I _{IN} Input current	-30 to +1	-30 to +5	mA
V _{OUT} Voltage applied to output in HIGH output state	-0.5 to +V _{CC}	-0.5 to +V _{CC}	V
T _A Operating free-air temperature range	0 to 70		°C

RECOMMENDED OPERATING CONDITIONS

PARAMETER	74LS			74S			UNIT
	Min	Nom	Max	Min	Nom	Max	
V _{CC} Supply voltage	4.75	5.0	5.25	4.75	5.0	5.25	V
V _{IH} HIGH-level input voltage	2.0			2.0			V
V _{IL} LOW-level input voltage			+0.8			+0.8	V
I _{IK} Input clamp current			-18			-18	mA
I _{OH} HIGH-level output current			-400			-1000	μA
I _{OL} LOW-level output current			8			20	mA
T _A Operating free-air temperature	0		70	0		70	°C

DC ELECTRICAL CHARACTERISTICS (Over recommended operating free-air temperature range unless otherwise noted.)

PARAMETER	TEST CONDITIONS ¹	74LS138			74S138			UNIT
		Min	Typ ²	Max	Min	Typ ²	Max	
V _{OH} HIGH-level output voltage	V _{CC} = MIN, V _{IH} = MIN, V _{IL} = MAX, I _{OH} = MAX	2.7	3.4		2.7	3.4		V
V _{OL} LOW-level output voltage	V _{CC} = MIN, V _{IH} = MIN, V _{IL} = MAX	I _{OL} = MAX	0.35	0.5			0.5	V
		I _{OL} = 4mA (74LS)	0.25	0.4				V
V _{IK} Input clamp voltage	V _{CC} = MIN, I _I = I _{IK}			-1.5			-1.2	V
I _I Input current at maximum input voltage	V _{CC} = MAX	V _I = 5.5V					1.0	mA
		V _I = 7.0V			0.1			mA
I _{IH} HIGH-level input current	V _{CC} = MAX, V _I = 2.7V			20			50	μA
I _{IL} LOW-level input current	V _{CC} = MAX	V _I = 0.4V			-0.4			mA
		V _I = 0.5V					-2	mA
I _{OS} Short-circuit output current ³	V _{CC} = MAX	-20		-100	-40		-100	mA
I _{CC} Supply current ⁴ (total)	V _{CC} = MAX		6.3	10		49	74	mA

NOTES:

- For conditions shown as MIN or MAX, use the appropriate value specified under recommended operating conditions for the applicable type.
- All typical values are at V_{CC} = 5V, T_A = 25°C.
- I_{OS} is tested with V_{OUT} = +0.5V and V_{CC} = V_{CC} MAX + 0.5V. Not more than one output should be shorted at a time and duration of the short circuit should not exceed one second.
- To measure I_{CC}, outputs must be enabled and open.

Decoders/Demultiplexers

74LS138, S138

AC WAVEFORMS

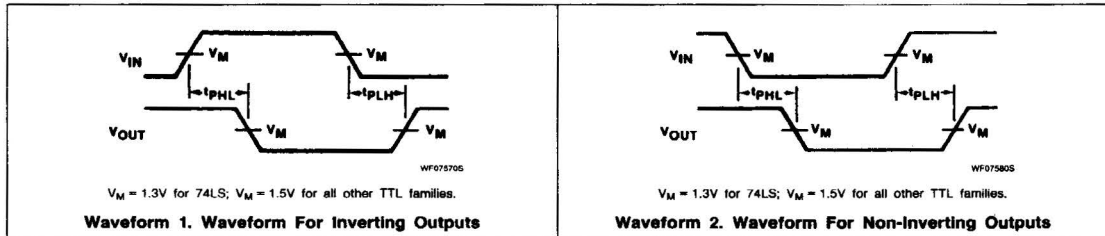

AC ELECTRICAL CHARACTERISTICS $T_A = 25^\circ\text{C}$, $V_{CC} = 5.0\text{V}$

PARAMETER	TEST CONDITIONS	74LS		74S		UNIT
		$C_L = 15\text{pF}$, $R_L = 2\text{k}\Omega$		$C_L = 15\text{pF}$, $R_L = 280\Omega$		
		Min	Max	Min	Max	
t_{PLH} t_{PHL}	Propagation delay Address to output	Waveform 2 2 logic levels		20 41	7 10.5	ns
t_{PLH} t_{PHL}	Propagation delay Address to output	Waveform 1 3 logic levels		27 39	12 12	ns
t_{PLH} t_{PHL}	Propagation delay Enable to output	Waveform 2 2 logic levels		18 32	8 11	ns
t_{PLH} t_{PHL}	Propagation delay Enable to output	Waveform 1 3 logic levels		26 38	11 11	ns

5

TEST CIRCUITS AND WAVEFORMS

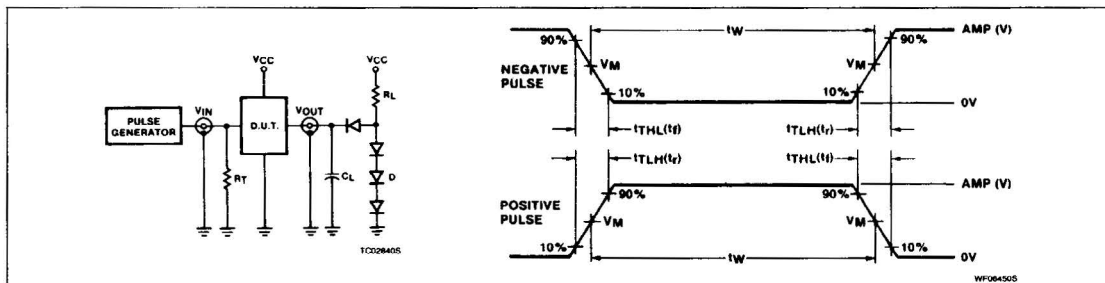

Test Circuit For 74 Totem-Pole Outputs

DEFINITIONS
 R_L = Load resistor to V_{CC} ; see AC CHARACTERISTICS for value.
 C_L = Load capacitance includes jig and probe capacitance; see AC CHARACTERISTICS for value.
 R_T = Termination resistance should be equal to Z_{OUT} of Pulse Generators.
 D = Diodes are 1N916, 1N3064, or equivalent.
 t_{TLH} , t_{THL} Values should be less than or equal to the table entries.

Input Pulse Definition

FAMILY	INPUT PULSE REQUIREMENTS				
	Amplitude	Rep. Rate	Pulse Width	t_{TLH}	t_{THL}
74	3.0V	1MHz	500ns	7ns	7ns
74LS	3.0V	1MHz	500ns	15ns	6ns
74S	3.0V	1MHz	500ns	2.5ns	2.5ns