

# DATA SHEET

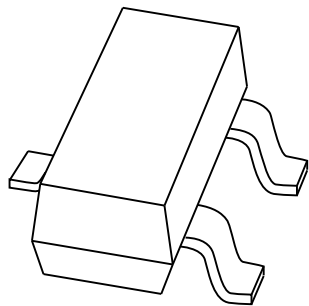

## **BC846; BC847; BC848** NPN general purpose transistors

Product specification  
Supersedes data of 1999 Apr 23

2002 Feb 04

# NPN general purpose transistors

# BC846; BC847; BC848

### FEATURES

- Low current (max. 100 mA)
- Low voltage (max. 65 V).

### APPLICATIONS

- General purpose switching and amplification.

### DESCRIPTION

NPN transistor in a SOT23 plastic package.  
 PNP complements: BC856, BC857 and BC858.

### MARKING

TYPE NUMBER	MARKING CODE <sup>(1)</sup>
BC846	1D*
BC846A	1A*
BC846B	1B*
BC847	1H*
BC847A	1E*
BC847B	1F*
BC847C	1G*
BC848B	1K*

### Note

1. \* = p: made in Hong Kong.  
 \* = t: made in Malaysia.

### PINNING

PIN	DESCRIPTION
1	base
2	emitter
3	collector

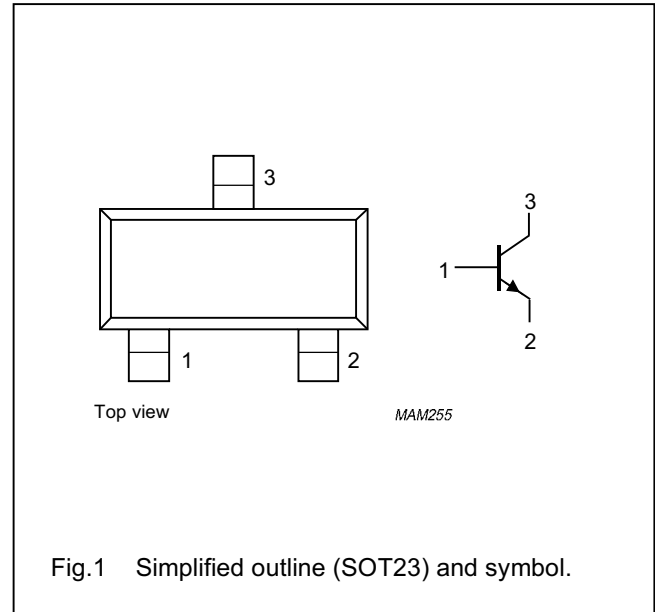

Fig.1 Simplified outline (SOT23) and symbol.

## NPN general purpose transistors

## BC846; BC847; BC848

**LIMITING VALUES**

In accordance with the Absolute Maximum System (IEC 60134).

SYMBOL	PARAMETER	CONDITIONS	MIN.	MAX.	UNIT
V <sub>CBO</sub>	collector-base voltage	open emitter			
	BC846		–	80	V
	BC847		–	50	V
	BC848	–	30	V	
V <sub>CEO</sub>	collector-emitter voltage	open base			
	BC846		–	65	V
	BC847		–	45	V
	BC848	–	30	V	
V <sub>EBO</sub>	emitter-base voltage	open collector			
	BC846; BC847		–	6	V
	BC848	–	5	V	
I <sub>C</sub>	collector current (DC)		–	100	mA
I <sub>CM</sub>	peak collector current		–	200	mA
I <sub>BM</sub>	peak base current		–	200	mA
P <sub>tot</sub>	total power dissipation	T <sub>amb</sub> ≤ 25 °C; note 1	–	250	mW
T <sub>stg</sub>	storage temperature		–65	+150	°C
T <sub>j</sub>	junction temperature		–	150	°C
T <sub>amb</sub>	operating ambient temperature		–65	+150	°C

**Note**

1. Transistor mounted on an FR4 printed-circuit board, standard footprint.

**THERMAL CHARACTERISTICS**

SYMBOL	PARAMETER	CONDITIONS	VALUE	UNIT
R <sub>th j-a</sub>	thermal resistance from junction to ambient	in free air; note 1	500	K/W

**Note**

1. Transistor mounted on an FR4 printed-circuit board, standard footprint.

## NPN general purpose transistors

## BC846; BC847; BC848

## CHARACTERISTICS

$T_{amb} = 25\text{ °C}$ ; unless otherwise specified.

SYMBOL	PARAMETER	CONDITIONS	MIN.	TYP.	MAX.	UNIT
$I_{CBO}$	collector-base cut-off current	$V_{CB} = 30\text{ V}; I_E = 0$	–	–	15	nA
		$V_{CB} = 30\text{ V}; I_E = 0;$ $T_J = 150\text{ °C}$	–	–	5	$\mu\text{A}$
$I_{EBO}$	emitter-base cut-off current	$V_{EB} = 5\text{ V}; I_C = 0$	–	–	100	nA
$h_{FE}$	DC current gain	$I_C = 10\text{ }\mu\text{A}; V_{CE} = 5\text{ V}$	–	90	–	
	BC846A; BC847A					
	BC846B; BC847B; BC848B		–	150	–	
	BC847C		–	270	–	
$h_{FE}$	DC current gain	$I_C = 2\text{ mA}; V_{CE} = 5\text{ V}$	110	–	450	
	BC846					
	BC847					
	BC846A; BC847A					
	BC846B; BC847B; BC848B					
	BC847C	420	520	800		
$V_{CEsat}$	collector-emitter saturation voltage	$I_C = 10\text{ mA}; I_B = 0.5\text{ mA}$	–	90	250	mV
		$I_C = 100\text{ mA}; I_B = 5\text{ mA};$ note 1	–	200	600	mV
$V_{BEsat}$	base-emitter saturation voltage	$I_C = 10\text{ mA}; I_B = 0.5\text{ mA}$	–	700	–	mV
		$I_C = 100\text{ mA}; I_B = 5\text{ mA};$ note 1	–	900	–	mV
$V_{BE}$	base-emitter voltage	$I_C = 2\text{ mA}; V_{CE} = 5\text{ V}$	580	660	700	mV
		$I_C = 10\text{ mA}; V_{CE} = 5\text{ V}$	–	–	770	mV
$C_c$	collector capacitance	$V_{CB} = 10\text{ V}; I_E = I_e = 0;$ $f = 1\text{ MHz}$	–	2.5	–	pF
$f_T$	transition frequency	$V_{CE} = 5\text{ V}; I_C = 10\text{ mA};$ $f = 100\text{ MHz}$	100	–	–	MHz
F	noise figure	$I_C = 200\text{ }\mu\text{A}; V_{CE} = 5\text{ V};$ $R_S = 2\text{ k}\Omega; f = 1\text{ kHz};$ $B = 200\text{ Hz}$	–	2	10	dB

## Note

1. Pulse test:  $t_p \leq 300\text{ }\mu\text{s}$ ;  $\delta \leq 0.02$ .

NPN general purpose transistors

BC846; BC847; BC848

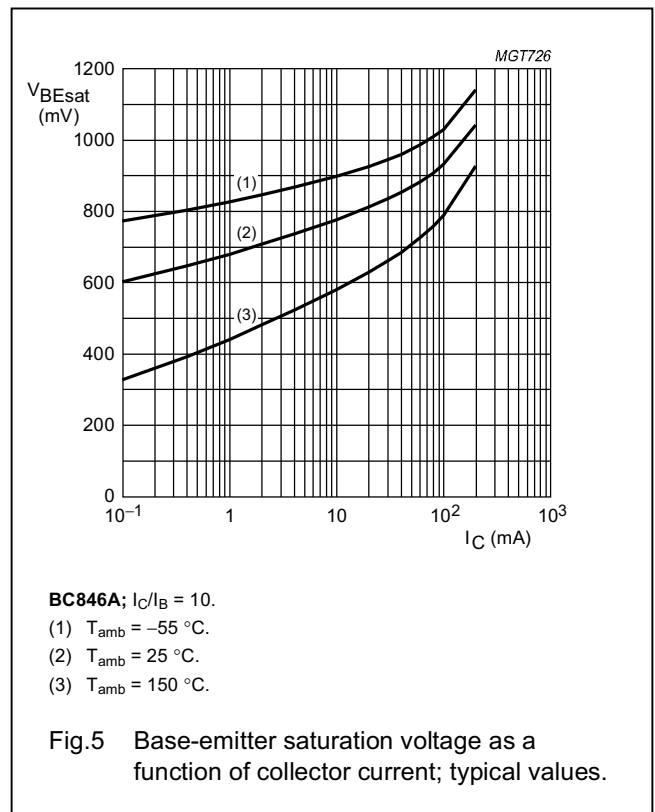
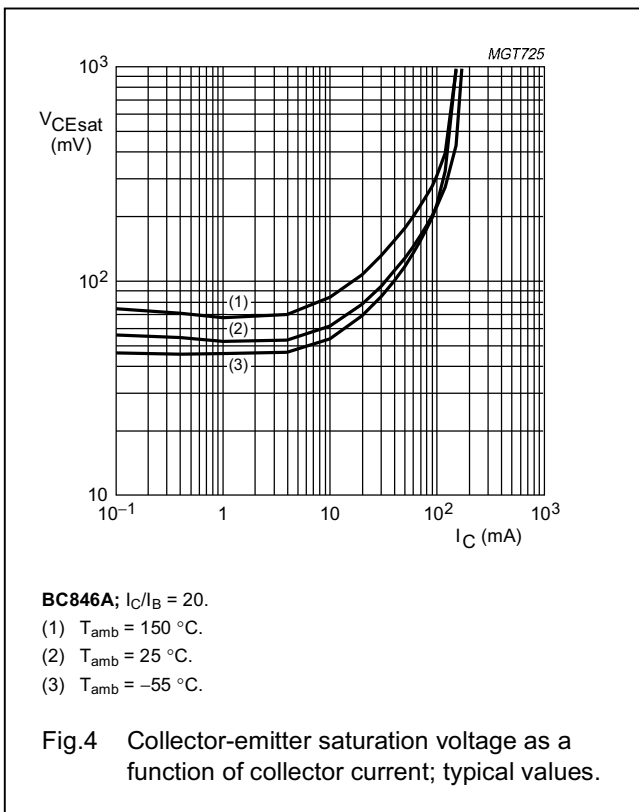
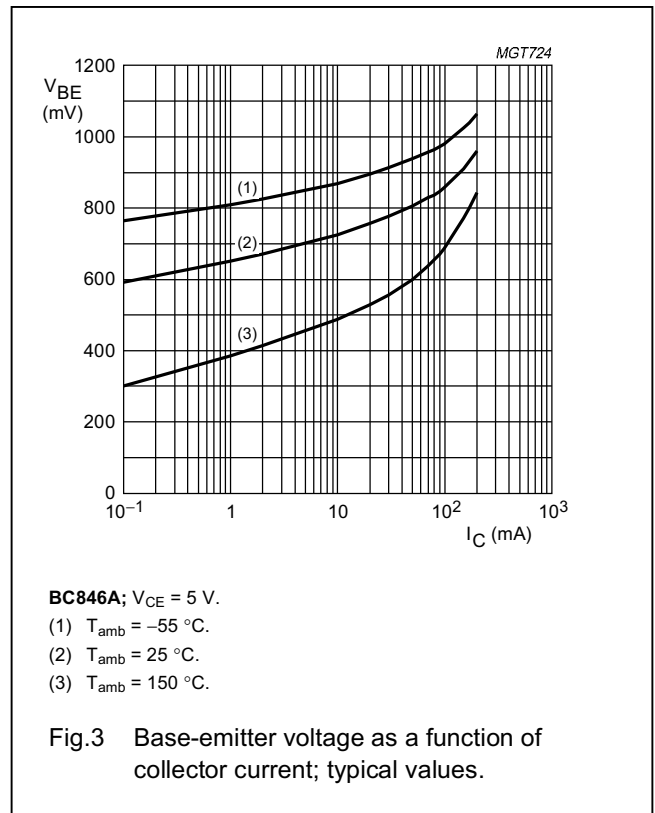
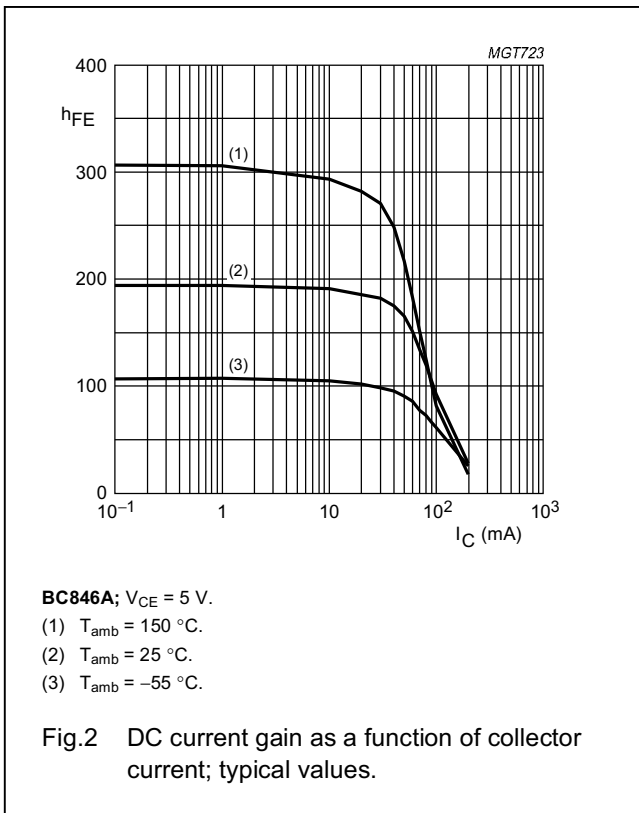

NPN general purpose transistors

BC846; BC847; BC848

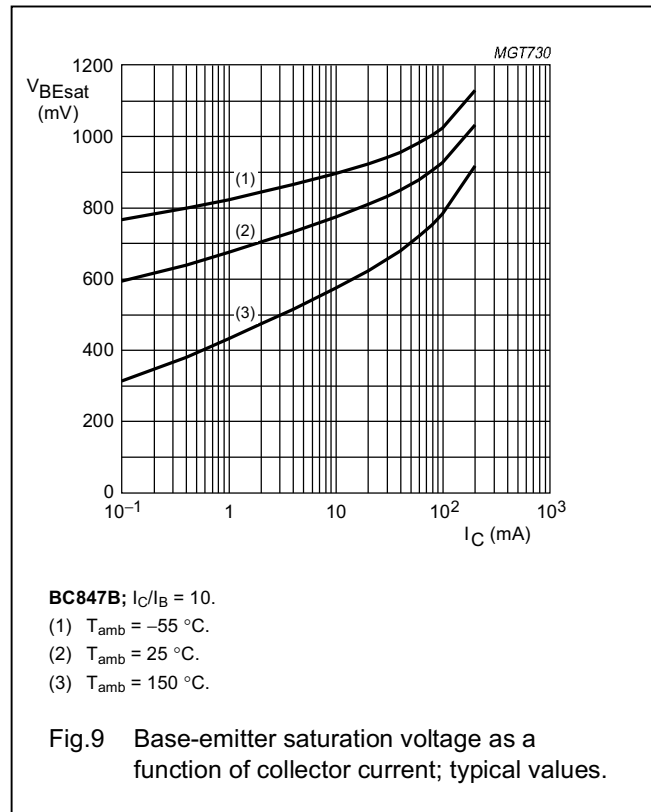
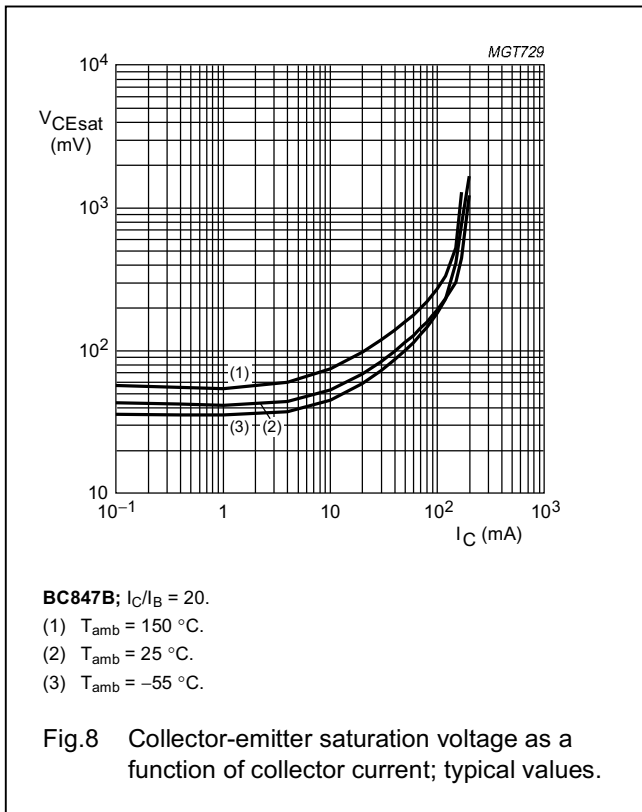
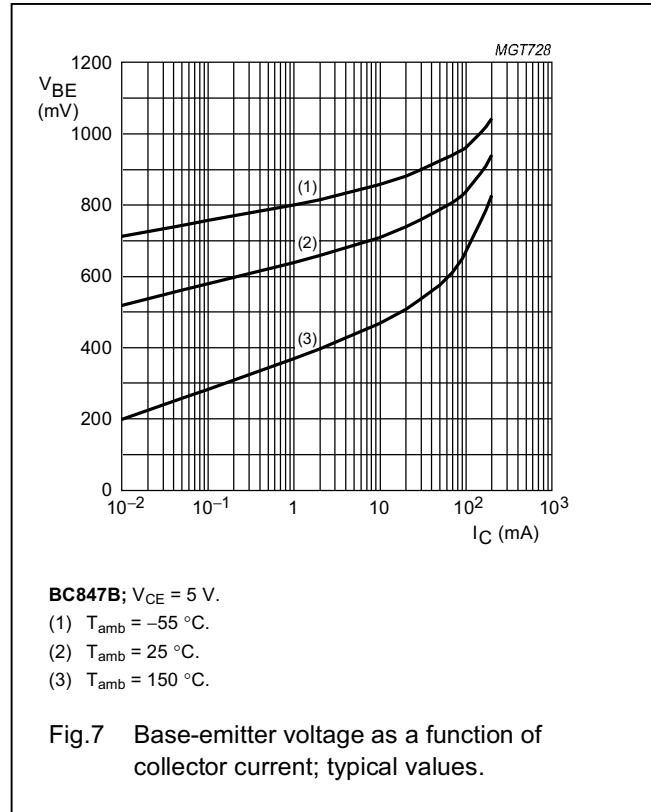
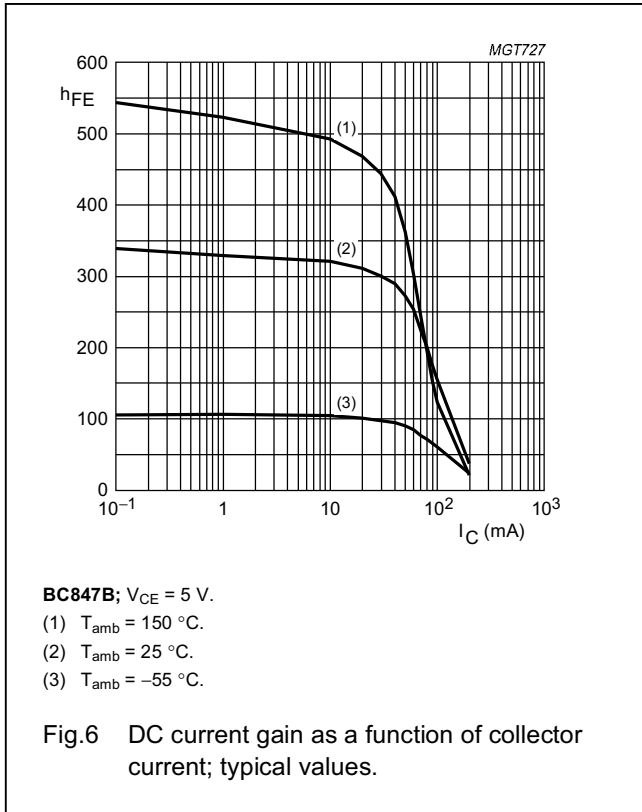

NPN general purpose transistors

BC846; BC847; BC848

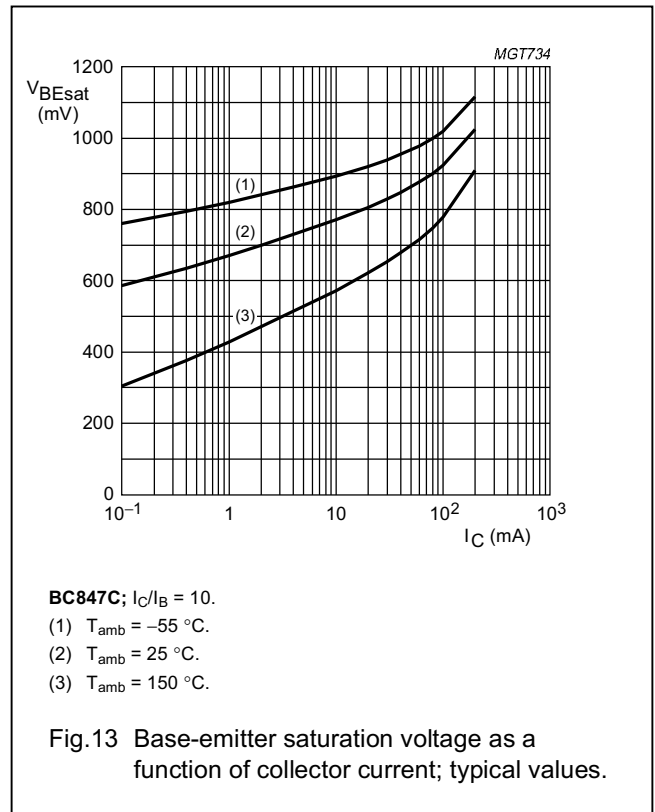
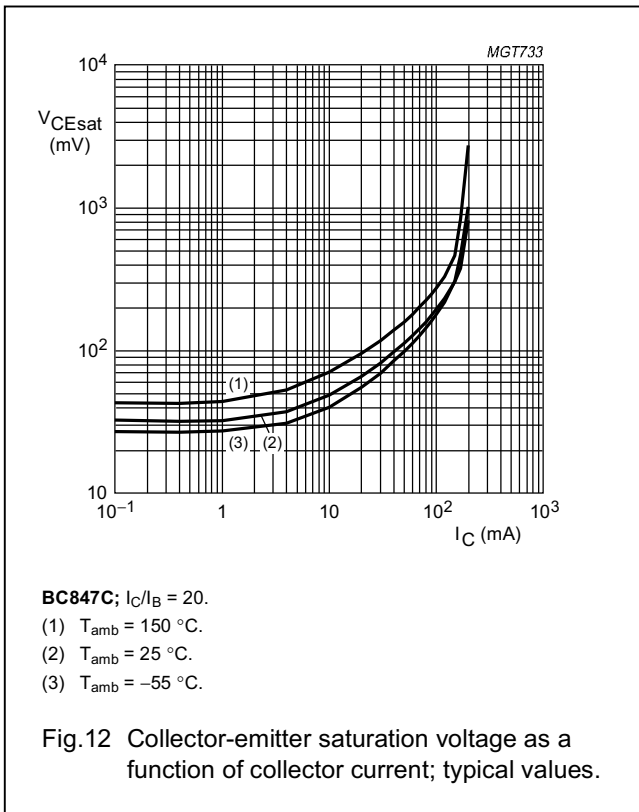
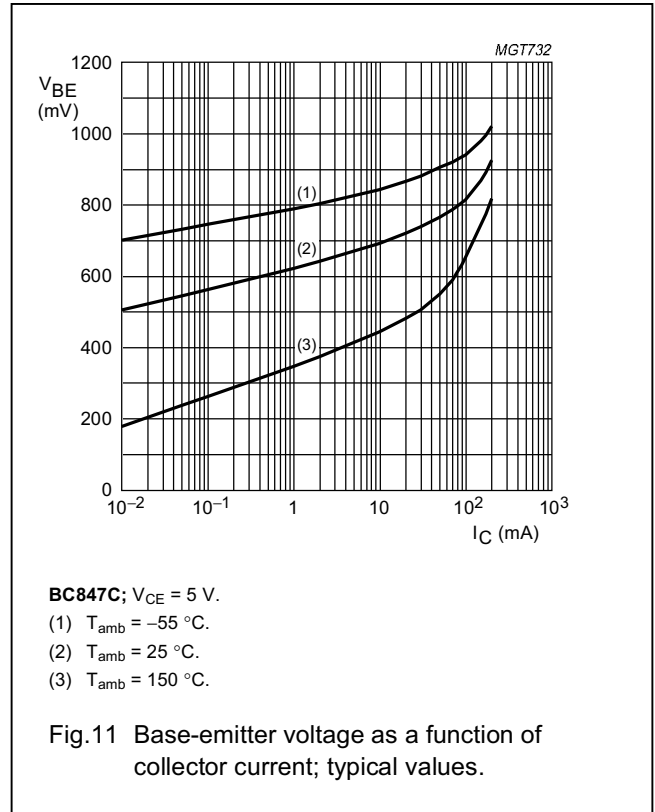
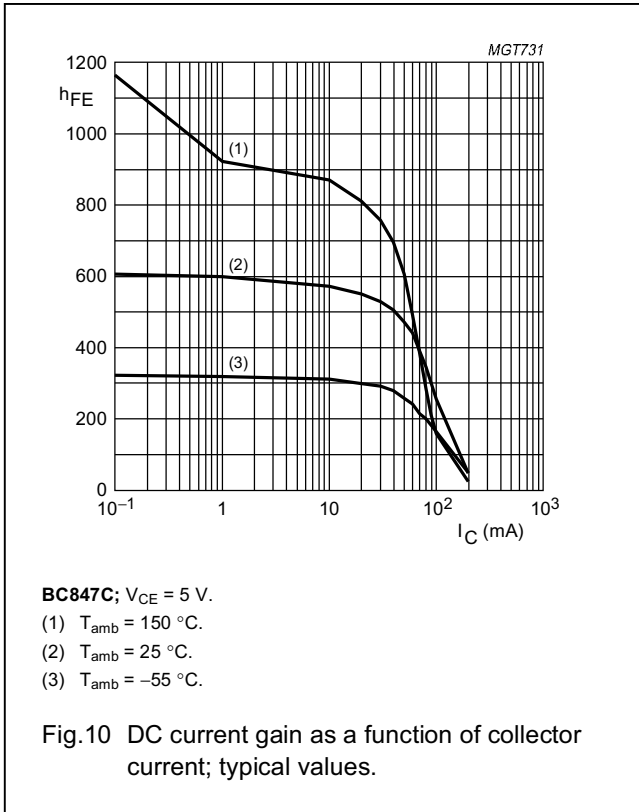

NPN general purpose transistors

BC846; BC847; BC848

PACKAGE OUTLINE

Plastic surface mounted package; 3 leads

SOT23

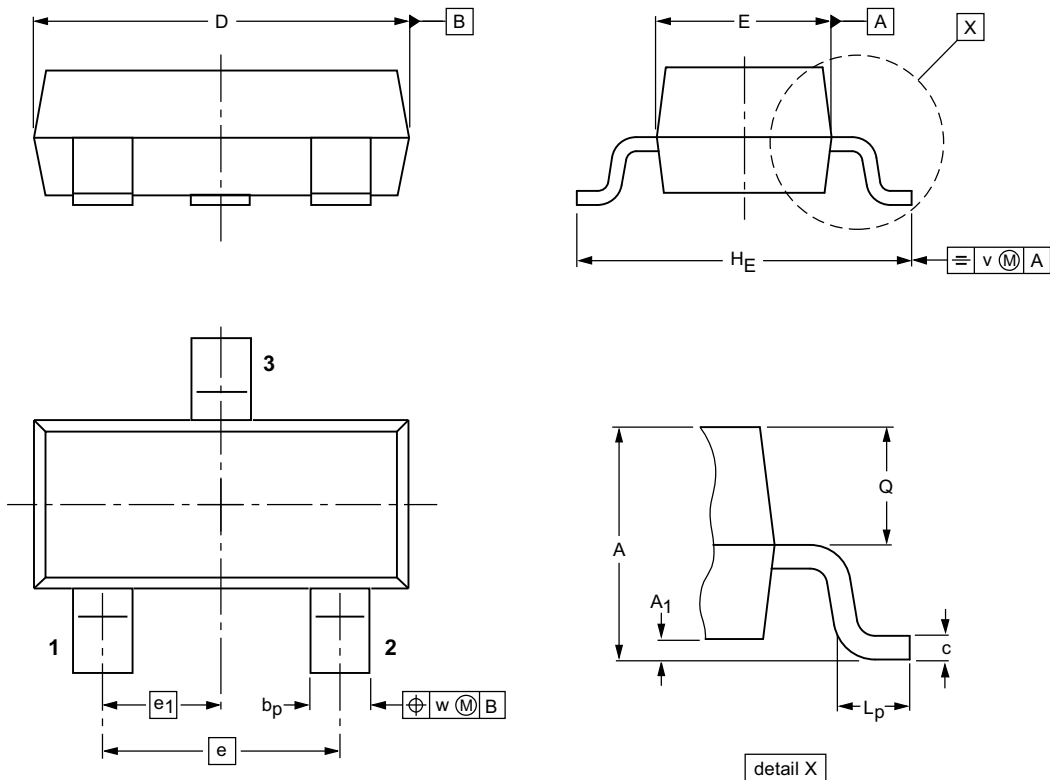

DIMENSIONS (mm are the original dimensions)

UNIT	A	A <sub>1</sub> max.	b <sub>p</sub>	c	D	E	e	e <sub>1</sub>	H <sub>E</sub>	L <sub>p</sub>	Q	v	w
mm	1.1 0.9	0.1	0.48 0.38	0.15 0.09	3.0 2.8	1.4 1.2	1.9	0.95	2.5 2.1	0.45 0.15	0.55 0.45	0.2	0.1

OUTLINE VERSION	REFERENCES				EUROPEAN PROJECTION	ISSUE DATE
	IEC	JEDEC	EIAJ			
SOT23		TO-236AB				97-02-28- 99-09-13



## NPN general purpose transistors

BC846; BC847; BC848

## DATA SHEET STATUS

DATA SHEET STATUS <sup>(1)</sup>	PRODUCT STATUS <sup>(2)</sup>	DEFINITIONS
Objective data	Development	This data sheet contains data from the objective specification for product development. Philips Semiconductors reserves the right to change the specification in any manner without notice.
Preliminary data	Qualification	This data sheet contains data from the preliminary specification. Supplementary data will be published at a later date. Philips Semiconductors reserves the right to change the specification without notice, in order to improve the design and supply the best possible product.
Product data	Production	This data sheet contains data from the product specification. Philips Semiconductors reserves the right to make changes at any time in order to improve the design, manufacturing and supply. Changes will be communicated according to the Customer Product/Process Change Notification (CPCN) procedure SNW-SQ-650A.

## Notes

1. Please consult the most recently issued data sheet before initiating or completing a design.
2. The product status of the device(s) described in this data sheet may have changed since this data sheet was published. The latest information is available on the Internet at URL <http://www.semiconductors.philips.com>.

## DEFINITIONS

**Short-form specification** — The data in a short-form specification is extracted from a full data sheet with the same type number and title. For detailed information see the relevant data sheet or data handbook.

**Limiting values definition** — Limiting values given are in accordance with the Absolute Maximum Rating System (IEC 60134). Stress above one or more of the limiting values may cause permanent damage to the device. These are stress ratings only and operation of the device at these or at any other conditions above those given in the Characteristics sections of the specification is not implied. Exposure to limiting values for extended periods may affect device reliability.

**Application information** — Applications that are described herein for any of these products are for illustrative purposes only. Philips Semiconductors make no representation or warranty that such applications will be suitable for the specified use without further testing or modification.

## DISCLAIMERS

**Life support applications** — These products are not designed for use in life support appliances, devices, or systems where malfunction of these products can reasonably be expected to result in personal injury. Philips Semiconductors customers using or selling these products for use in such applications do so at their own risk and agree to fully indemnify Philips Semiconductors for any damages resulting from such application.

**Right to make changes** — Philips Semiconductors reserves the right to make changes, without notice, in the products, including circuits, standard cells, and/or software, described or contained herein in order to improve design and/or performance. Philips Semiconductors assumes no responsibility or liability for the use of any of these products, conveys no licence or title under any patent, copyright, or mask work right to these products, and makes no representations or warranties that these products are free from patent, copyright, or mask work right infringement, unless otherwise specified.

NPN general purpose transistors

BC846; BC847; BC848

---

**NOTES**

NPN general purpose transistors

BC846; BC847; BC848

---

**NOTES**

# ***Philips Semiconductors – a worldwide company***

## **Contact information**

For additional information please visit <http://www.semiconductors.philips.com>. Fax: **+31 40 27 24825**

For sales offices addresses send e-mail to: [sales.addresses@www.semiconductors.philips.com](mailto:sales.addresses@www.semiconductors.philips.com).

© Koninklijke Philips Electronics N.V. 2002

SCA74

All rights are reserved. Reproduction in whole or in part is prohibited without the prior written consent of the copyright owner.

The information presented in this document does not form part of any quotation or contract, is believed to be accurate and reliable and may be changed without notice. No liability will be accepted by the publisher for any consequence of its use. Publication thereof does not convey nor imply any license under patent- or other industrial or intellectual property rights.

Printed in The Netherlands

613514/04/pp12

Date of release: 2002 Feb 04

Document order number: 9397 750 09165

*Let's make things better.*

**Philips  
Semiconductors**



**PHILIPS**