

Safety according to IEC/EN 60950, UL 1950



<sup>1</sup> For 70/110IMX types

**Wide input voltage ranges up to 150 VDC**  
**1 or 2 outputs up to 48 VDC**  
**1500 to 2500 VDC I/O electric strength test**

**Features**

- RoHS lead solder exemption compliant
- Extremely wide input voltage ranges
- Electrical isolation, also between outputs
- Emissions below EN 55 022 level B.
- Immunity to IEC/EN 61000-4-2, -3, -4, -5 and -6
- High efficiency (typ. 84%)
- Inhibit input, output voltage adjustable
- Flex power: flexible load distribution on outputs
- Outputs no-load, overload and short-circuit proof
- Operating ambient temperature up to -40 to 85°C
- High reliability and no derating
- 2" x 1" case with 10.5 mm profile
- Supplementary insulation

**Description**

The IMX7 Series of board-mountable 7-watt dc-dc converters has been designed according to the latest industry requirements and standards. The converters are particularly suitable for use in mobile or stationary applications in transport, railways, industry or telecommunications where variable input voltages or high transient voltages are prevalent.

Covering a total input voltage range from 8.4 VDC up to 150 VDC with four different types the units are available with single and electrically isolated double outputs allowing the configuration of output voltages from 3.3 VDC up to 48 VDC externally adjustable, with flexible load distribution on double output units. An inhibit input allows remote converter on/off.

Features include efficient input and output filtering with unsurpassed transient and surge protection, low output ripple and noise, consistently high efficiency over the entire input voltage range, high reliability as well as excellent dynamic response to load and line changes.

The converters provide supplementary insulation with SELV outputs as e.g., required in battery supported systems where the bus voltage may exceed the SELV limit of 60 VDC. They are

designed and built according to the international safety standards IEC/EN 60950, UL 1950, CAN/CSA C22.2 No.950-95 and are LGA and UL marked. The 70IMX7 and 110IMX7 types are CE marked.

The circuit comprises of integrated planar magnetics and all components are automatically assembled and solidly soldered onto a single PCB without any wire connections. Magnetic feedback ensures maximum reliability and repeatability in the control loop over all operating conditions. Careful considerations of possible thermal stresses ensure the absence of hot spots providing long life in environments where temperature cycles are a reality. The thermal design allows operation at full load up to an ambient temperature of 85°C in free air without using any potting material. For extremely high vibration environments the case has holes for screw mounting.

Various options such as extended temperature range -40 to 85°C and an uncased low profile version provide a high level of application specific engineering and design-in flexibility.

**Table of Contents**

Table of Contents	Page	Page	
Description .....	1	Auxiliary Functions .....	19
Model Selection .....	2	Electromagnetic Compatibility (EMC) .....	11
Part Number Description .....	3	Immunity to Environmental Conditions .....	12
Functional Description .....	3	Mechanical Data .....	13
Electrical Input Data .....	4	Safety and Installation Instructions .....	14
Electrical Output Data .....	6	Description of Options .....	15



**Model Selection**

Table 1: Part Number Descriptions

Output 1		Output 2		Output Power	Input voltage	Efficiency	Type	
Options <sup>2</sup>						designation		
V <sub>o1 nom</sub> [VDC]	I <sub>o1 nom</sub> [A] <sup>1</sup>	V <sub>o2 nom</sub> [VDC]	I <sub>o2 nom</sub> [A] <sup>1</sup>	P <sub>o nom</sub> [W]	range [VDC]	η <sub>typ</sub> [%]		
3.3	1.5	-	-	5	8.4 - 36	79	20IMX7-03-8	-9, Z
3.3	1.5	-	-	5	16.8 - 75 <sup>3</sup>	81	40IMX7-03-8	-9, Z
3.3	1.5	-	-	5	40 - 121	79	70IMX7-03-8	-9
3.3	1.5	-	-	5	60 - 150	79	110IMX7-03-8	-9
5.1	1.2	-	-	6.1	8.4 - 36	80	20IMX7-05-8	-9, Z
5.1	1.2	-	-	6.1	16.8 - 75 <sup>3</sup>	81	40IMX7-05-8	-9, Z
5.1	1.2	-	-	6.1	40 - 121	80	70IMX7-05-8	-9
5.1	1.2	-	-	6.1	60 - 150	80	110IMX7-05-8	-9
5	0.6	5	0.6	6	8.4 - 36	82	20IMX7-05-05-8	-9, Z
5	0.7	5	0.7	7	16.8 - 75 <sup>3</sup>	83	40IMX7-05-05-8	-9, Z
5	0.7	5	0.7	7	40 - 121	82	70IMX7-05-05-8	-9
5	0.7	5	0.7	7	60 - 150	82	110IMX7-05-05-8	-9
12	0.25	12	0.25	6	8.4 - 36	84	20IMX7-12-12-8	-9, Z
12	0.3	12	0.3	7.2	16.8 - 75 <sup>3</sup>	84	40IMX7-12-12-8	-9, Z
12	0.3	12	0.3	7.2	40 - 121	83	70IMX7-12-12-8	-9
12	0.3	12	0.3	7.2	60 - 150	84	110IMX7-12-12-8	-9
15	0.2	15	0.2	6	8.4 - 36	84	20IMX7-15-15-8	-9, Z
15	0.24	15	0.24	7.2	16.8 - 75 <sup>3</sup>	84	40IMX7-15-15-8	-9, Z
15	0.24	15	0.24	7.2	40 - 121	83	70IMX7-15-15-8	-9
15	0.24	15	0.24	7.2	60 - 150	84	110IMX7-15-15-8	-9
24	0.13	24	0.13	6.2	8.4 - 36	84	20IMX7-24-24-8	-9, Z
24	0.15	24	0.15	7.2	16.8 - 75 <sup>3</sup>	84	40IMX7-24-24-8	-9, Z
24	0.15	24	0.15	7.2	40 - 121	83	70IMX7-24-24-8	-9
24	0.15	24	0.15	7.2	60 - 150	84	110IMX7-24-24-8	-9

<sup>1</sup> Flexible load distribution on double outputs possible.

<sup>2</sup> For single output models it is recommended to parallel the two outputs of a dual unit.

<sup>3</sup> Operation at lower input voltage possible: P<sub>o</sub> approx. 80% of P<sub>o nom</sub> at V<sub>i min</sub> = 14.4 V.

Items in yellow or shaded are not recommended for new designs.

**Part Number Description**

- Input voltage range V<sub>i</sub>
  - 8.4 - 36 VDC ..... 20
  - 16.8 - 75 VDC ..... 40
  - 40 - 121 VDC ..... 70
  - 60 - 150 VDC ..... 110
- Series ..... IMX7
- Output voltage type output 1 ..... 03, 05, 12, 15, 24
- Dash: Designates double output unit with two independent electrically isolated outputs .....
- Output voltage type output 2 ..... 05, 12, 15, 24
- Operating ambient temperature range T<sub>A</sub>
  - 40 to 71 °C (option) ..... -9
  - 40 to 85 °C ..... -8
- Options:<sup>2</sup> (Surface mount version - NFND) ..... M <sup>1 2</sup>
- (C-pinout - NFND) ..... C <sup>1 2</sup>
- (Open frame - NFND) ..... Z

20 IMX7 - 05 - 05 - 8 M C Z .

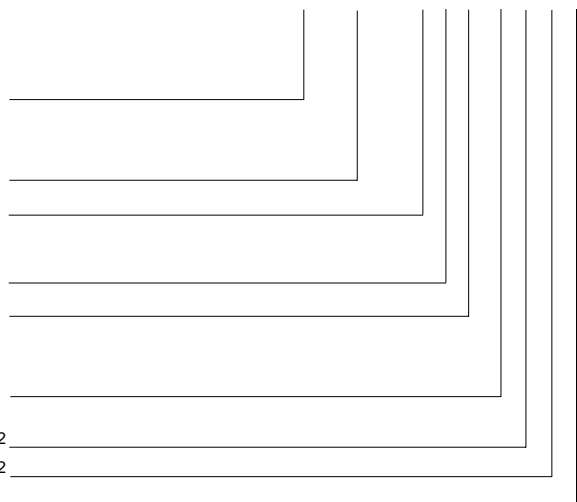

<sup>1</sup> Option M and Z excludes option C and vice versa.

<sup>2</sup> For delivery lead times contact factory. Some types are not recommended for new designs (NFND = not for new designs).

Examples: 40IMX7-05-05-8: dc-dc converter, input voltage range 16.8 - 75V, 2 electrically isolated outputs each providing 5V, 700 mA.

## Functional Description

The IMX7 dc-dc modules are feedback controlled flyback converters using current mode PWM (Pulse Width Modulation). See block diagram for single and double output types.

In the case of the single output units the output is directly monitored and fed back to the primary control circuit via a pulse transformer, resulting in tight regulation of the output voltage. The R input is referenced to the secondary side and allows for programming of the output voltages in the range 75 to 105% of  $V_{o\ nom}$  using either an external resistor or an external voltage source.

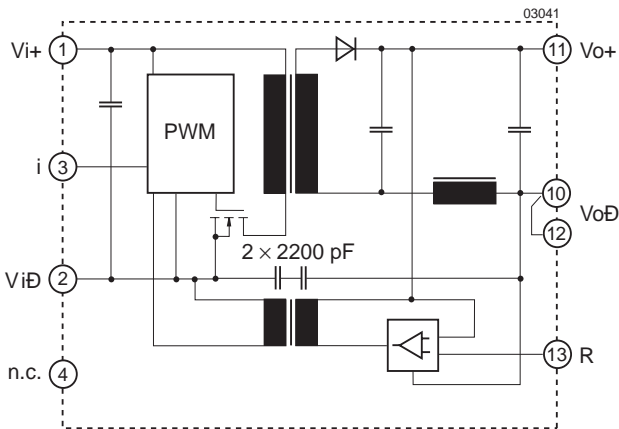

Fig. 1  
Block diagram, single output types, standard pinout

In the case of the dual and double output units the output voltage is monitored by a separate transformer winding close to the secondary windings and fed back to the control circuit. The R (Trim) input is referenced to the primary side and allows programming of the output voltage in the range 100 to 105% of  $V_{o\ nom}$  by an external resistor or within 75 to 105% of  $V_{o\ nom}$  using an external voltage source.

Current limitation is provided by the primary circuit, thus limiting the total output power.

The inhibit input allows remote converter on/off.

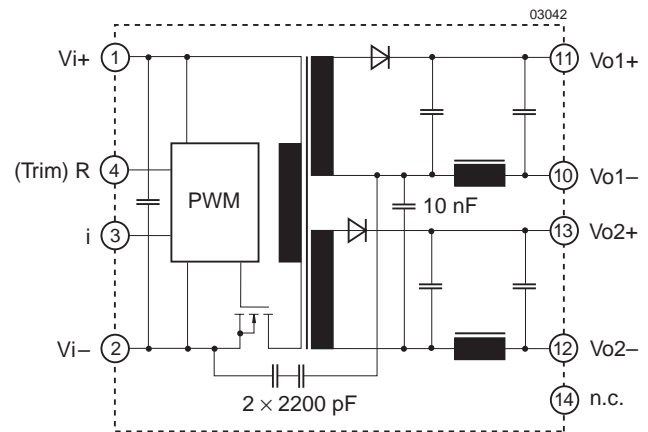

Fig. 2  
Block diagram, double output types, standard pinout

### Electrical Input Data

General conditions:

- $T_A = 25^\circ\text{C}$ , unless  $T_C$  is specified.
- Connector pins i and Vi– interconnected.
- Trim or R input not connected.

Table 2: Input Data

Input			20IMX7		40IMX7		70IMX7		110IMX7		Unit				
Characteristics		Conditions	min	typ	max	min	typ	max	min	typ	max				
$V_i$	Input voltage range <sup>1</sup>	$T_C \text{ min...} T_C \text{ max}$ $I_o = 0...I_o \text{ nom}$	8.4		36	16.8 <sup>6</sup>		75	40		121	60		150	V DC
$V_{i \text{ nom}}$	Nominal input voltage		20		40		70		110						
$V_{i \text{ sur}}$	Repetitive surge voltage	abs. max input (3 s)			100										
		150 V	50 <sup>5</sup>		4		4		4						
$t_{\text{start up}}$	Converter <sup>2</sup> start-up time	switch on	0.25		0.5		0.25		0.5		0.25		0.5		s
		inh. release	0.1		0.1		0.1		0.1		0.1		0.1		
$t_{\text{rise}}$	Rise time <sup>2</sup>	$V_{i \text{ nom}}$ resistive load	5		5		5		5		5		5		ms
		$I_o \text{ nom}$ capacitive load	12		12		12		12		12		12		
$I_o$	No load input current	$I_o = 0, V_{i \text{ min...} V_{i \text{ max}}}$	15		30	8		15	8		15	8		15	mA
$C_i$	Input capacitance	for surge calculation	4.7		0.5		0.2		0.2		0.2		0.2		$\mu\text{F}$
$V_{\text{inh}}$	Inhibit voltage	unit operating	-10...0.8		-10 ...0.8		-10 ...0.8		-10 ...0.8		-10 ...0.8		-10 ...0.8		V DC
		unit inhibited	open or 2.4... $V_{i \text{ max}}$		open or 2.4... $V_{i \text{ max}}$		open or 2.4...75		open or 2.4...75		open or 2.4...75		open or 2.4...75		
$I_{\text{inh}}$	Inhibit current	unit operating	-0.5		-0.5		-0.5		-0.5		-0.5		-0.5		mA
		unit inhibited	1		1		1		1		1		1		
$I_{i \text{ inh}}$	Input current if unit shut down	$V_{i \text{ min...} V_{i \text{ max}}}$	<3.0		<3.0		<3.0		<3.0		<3.0		<3.0		
$I_{\text{inr p}}$	Inrush peak current	$V_i = V_{i \text{ nom}}^7$	3.8		3.7		4.2		5.6		5.6		5.6		A
$f_s$	Switching frequency	$V_{i \text{ min...} V_{i \text{ max}}}, I_o = 0...I_o \text{ nom}$	approx. 400		approx. 400		approx. 400		approx. 300		approx. 300		approx. 300		
$I_{i \text{ rr}}$	Reflected ripple current	$I_o = 0...I_o \text{ nom}$	50		30		20		10		10		10		$\text{mA}_{\text{pp}}$
		EN 55022 <sup>3</sup>	B		B		B		B		B		B		

conducted and radiated

<sup>1</sup>  $V_{i \text{ min}}$  will not be as stated if  $V_o$  is increased above  $V_o \text{ nom}$  by use of the R input. If the output voltage is set to a higher value,  $V_{i \text{ min}}$  will be proportionally increased.

<sup>2</sup> Measured with a resistive and max. admissible capacitive load.

<sup>3</sup> Measured with a lead length of 0.1 m, leads twisted. Double output units with both outputs in parallel. 70/110 IMX7 types need an external capacitor at the input. (e.g. 1 $\mu\text{F}$  film or ceramic)

<sup>4</sup> See 19 Pfl 1: *Electromagnetic Immunity*.

<sup>5</sup> The DC-DC converter shuts down automatically at approx. 38 V.

<sup>6</sup> Operation at lower input voltage possible:  $P_o$  approx. 80% of  $P_o \text{ nom}$  at  $V_{i \text{ min}} = 14.4$  V.

<sup>7</sup> Source impedance according to prETS 300132-2, version 4.3, at  $V_{i \text{ nom}}$ .

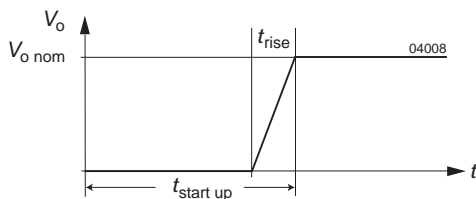

Fig. 3  
Converter start-up and rise time

**Input Transient Voltage Protection**

In many applications transient voltages on the input of the converter are always possible. These may be caused for example by short circuits between Vi+ and Vi- where the network inductance may cause high energy pulses.

In order to protect the converters the IMX7 types have a built-in transient protection as per table below:

Table 3: Built-in transient voltage suppressor

Type	Breakdown Voltage $V_{BR\ nom}$	Peak Power at 1 ms $P_P$	Peak Pulse Current $I_{PP}$
20IMX7 <sup>1</sup>	overvoltage lockout at approx. 38 V		
40IMX7 <sup>2</sup>	100 V	1500 W	11 A
70IMX7 <sup>2</sup>	144 V	600 W	2.9 A
110IMX7 <sup>2</sup>	167 V	600 W	2.5 A

<sup>1</sup> The built-in overvoltage lockout circuit shuts down the converter at approx. 38 V protecting the input up to 50 V DC. For higher transient voltages an external suppressor or voltage limiting circuit as e.g. for IEC/EN 61000-4-5, level 2 compliance should be provided.

<sup>2</sup> If transients generating currents above the peak pulse current are possible then an external limiting network such as the circuit recommended for IEC/EN 61000-4-5, level 2 compliance is necessary.

Table 4: Components for external circuitry to comply with IEC/EN 61000-4-5

Circuit Ref.	20IMX7	40IMX7	70IMX7	110IMX7
L	330 $\mu$ H, 0,115 $\Omega$ , 1 A TDK SF-T8-110S-01	330 $\mu$ H, 0,42 $\Omega$ , 600 mA TDK TSL1110-331KR55	1000 $\mu$ H, 2,9 $\Omega$ , 290 mA Toko 822LY-102K	330 $\mu$ H, 0,65 $\Omega$ , 430 mA Toko 822LY-331K
C	68 $\mu$ F, 63 V, 85°C	68 $\mu$ F, 100 V, 85°C	47 $\mu$ F, 150 V, 85°C	200 $\mu$ F, 200 V, 105°C
D	Motorola 1.5KE39A	n.a.	n.a.	n.a.

**Reverse Polarity Protection at Input**

The suppressor diode on the input also provides for reverse polarity protection by conducting current in the reverse direction, thus protecting the unit. An external fuse is required to limit this current:

- For 20IMX7 a fast 2 A (F2A) fuse is recommended.
- For 40IMX7 a fast 1 A (F1A) fuse is recommended.
- For 70IMX7 a fast 0.63 A (F.63A) fuse is recommended.
- For 110IMX7 a fast 0.63 A (F.63A) fuse is recommended.

**Inrush Current**

The inrush current has been kept as low as possible by choosing a very small input capacitance. A series resistor may be inserted in the input line to limit this current further.

To achieve IEC/EN 61000-4-5, level 2 compliance an additional inductor and capacitor should be provided externally as shown in the figure below. The components should have similar characteristics as listed in table: *Components for external circuitry to comply with IEC/EN 61000-4-5.*

Please note: The suppressor diode D is only necessary for 20IMX7 types. To withstand 150 V transients according to 19 Pfl 1, applicable for 40 IMX 7 types, the same external circuitry with similar components as for IEC/EN 61000-4-5, level 2 compliance can be used.

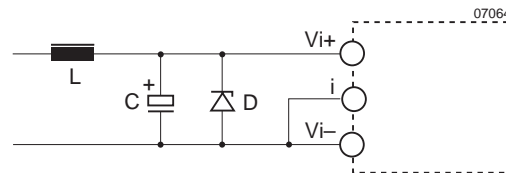

Fig. 4  
Example for external circuitry to comply with IEC/EN 61000-4-5, level 2 (transzorb D not necessary for 40/70/110IMX7 types).

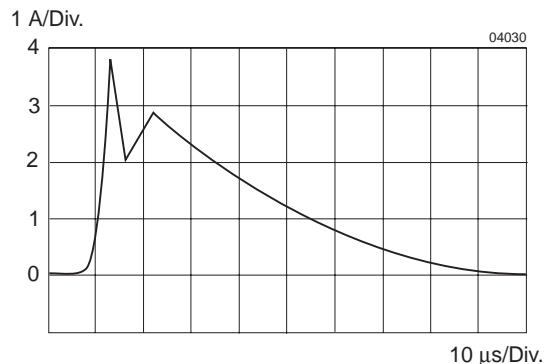

Fig. 5  
Typical inrush current at  $V_{i\ nom}$ ,  $P_{o\ nom}$  vs. time (40IMX7) measured according to prETS 300132-2 (Version 4.3)

### Electrical Output Data

General conditions:

- $T_A = 25\text{ °C}$ , unless  $T_C$  is specified.
- Connector pins i and Vi– interconnected.
- Trim or R input not connected.

Table 5a: Output data for single output units

Output		$V_{o\text{ nom}}$	3.3 V			5.1 V			Unit
Characteristics		Conditions	min	typ	max	min	typ	max	
$V_{o1}$	Output voltage	$V_{i\text{ nom}}$	3.28	3.32		5.07	5.13		VDC
$I_{o\text{ nom}}$	Output current	$V_{i\text{ min}}$ to $V_{i\text{ max}}$	1.5			1.2			A
$I_{o\text{ L}}$	Current limit <sup>2</sup>	$V_{i\text{ nom}}$ , $T_C = 25\text{ °C}$	3.0			2.4			
$\Delta V_o$	Line and load regulation	$V_{i\text{ min}}$ to $V_{i\text{ max}}$ $I_o = (0.05 \text{ to } 1) I_{o\text{ nom}}$	$\pm 1$			$\pm 1$			%
$V_{o1,2}$	Output voltage noise 20/40/70IMX 110IMX	$V_{i\text{ min}}$ to $V_{i\text{ max}}$ $I_o = I_{o\text{ nom}}$	<sup>5</sup> 70			70			mV <sub>pp</sub>
			<sup>6</sup> 20 40			20 40			
			40 50			40 50			
$V_{o\text{ clp}}$	Output overvoltage limitation <sup>7</sup>		115	130		115	130	%	
$C_{o\text{ ext}}$	Admissible capacitive load		$\leq 2500$			$\leq 2000$			$\mu\text{F}$
$V_{o\text{ d}}$	Dynamic load regulat.	Voltage deviat.	$V_{i\text{ nom}}$			$\pm 250$			mV
$t_d$		Recovery time	$I_{o\text{ nom}} \times 1/2 I_{o\text{ nom}}$			1			ms
$\alpha_{V_o}$	Temperature coefficient $\Delta V_o / \Delta T_C$ ( $T_{C\text{ min}}$ to $T_{C\text{ max}}$ )	$V_{i\text{ min}}$ to $V_{i\text{ max}}$ $I_o = 0$ to $I_{o\text{ max}}$	$\pm 0.02$			$\pm 0.02$			%/K

Table 5b: Output data for single output units

Output		$V_{o\text{ nom}}$	12 V			15 V			24 V			Unit
Characteristics		Conditions	min	typ	max	min	typ	max	min	typ	max	
$V_{o1}$	Output voltage	$V_{i\text{ nom}}$	11.90	12.10		14.88	15.12		23.81	24.19		VDC
$I_{o\text{ nom}}$	Output current <sup>1</sup>	$V_{i\text{ min}}$ to $V_{i\text{ max}}$	20IMX			0.5			0.4			A
			40/70/110IMX			0.6			0.48			
$I_{o\text{ L}}$	Current limit 2, 3	$V_{i\text{ nom}}$ , $T_C = 25\text{ °C}$	20IMX			1.0			0.95			%
			40/70/110IMX			1.2			1.1			
$\Delta V_o$	Line regulation	$V_{i\text{ min}}$ to $V_{i\text{ max}}$ , $I_o\text{ nom}$	$\pm 1$			$\pm 1$			$\pm 1$			
$\Delta V_{o1}$	Load regulation <sup>4</sup>	$V_{i\text{ nom}}$ $I_o = (0.1 \text{ to } 1) I_{o\text{ nom}}$	$\pm 3$			$\pm 3$			$\pm 3$			
$V_{o1,2}$	Output voltage noise	$V_{i\text{ min}}$ to $V_{i\text{ max}}$ $I_o = I_{o\text{ nom}}$	<sup>5</sup> 120			150			240			mV <sub>pp</sub>
			<sup>6</sup> 25 50			30 60			50 100			
$V_{o\text{ clp}}$	Output overvoltage limit. <sup>7</sup>	Minimum load 1%	115	130		115	130		115	130		%
$C_{o\text{ ext}}$	Admissible capacitive load <sup>3</sup>		$\leq 300$			$\leq 200$			$\leq 100$			$\mu\text{F}$
$V_{o\text{ d}}$	Dynamic load regulat.	Voltage deviat.	$V_{i\text{ nom}}$			$\pm 330$			$\pm 350$			mV
$t_d$		Recovery time	$I_{o\text{ nom}} \times 1/2 I_{o\text{ nom}}$			1			1			ms
$\alpha_{V_o}$	Temperature coefficient $\Delta V_o / \Delta T_C$ ( $T_{C\text{ min}}$ to $T_{C\text{ max}}$ )	$V_{i\text{ min}}$ to $V_{i\text{ max}}$ $I_o = 0$ to $I_{o\text{ max}}$	$\pm 0.02$			$\pm 0.02$			$\pm 0.02$			%/K

<sup>1</sup> Each output is capable of delivering full output power,  $P_{o\text{ nom}}$  according to table: Model Selection.

<sup>2</sup> The current limit is primary side controlled.

<sup>3</sup> Measured with both outputs connected in parallel.

<sup>4</sup> Conditions for specified output. Other output loaded with constant current  $I_o = 0.5 I_{o\text{ nom}}$ .

<sup>5</sup> BW = 20 MHz

<sup>6</sup> Measured with a probe according to EN 61204.

<sup>7</sup> The overvoltage protection is not tracking with the R control.

Table 5c: Output data for double output units

Output		$V_{o\ nom}$	2 X 5 V		2 X 12 V		2 X 15 V		2 X 24 V		Unit	
Characteristics	Conditions		min	typ	max	min	typ	max	min	typ	max	
$V_{o1}$ $V_{o2}$	Output voltage	$V_{i\ nom}$ $I_o = 0.5 I_{o\ nom}$	4.96	5.04	11.90	12.10	14.88	15.12	23.81	24.19	VDC	
			4.95	5.05	11.88	12.12	14.85	15.15	23.75	24.25		
$I_{o\ nom}$	Output current <sup>1</sup>	$V_{i\ min}$ to $V_{i\ max}$	2 ∞ 0.6		2 ∞ 0.25		2 ∞ 0.2		2 ∞ 0.13		A	
	20IMX 40/70/110IMX		2 ∞ 0.7		2 ∞ 0.3		2 ∞ 0.24		2 ∞ 0.15			
$I_{oL}$	Current limit 2, 3	$V_{i\ nom}, T_C = 25^\circ C$	2.4		1.0		0.95		0.5			
	20IMX 40/70/110IMX		2.8		1.2		1.1		0.6			
$\Delta V_o$	Line regulation	$V_{i\ min}$ to $V_{i\ max}, I_{o\ nom}$	±1		±1		±1		±1		%	
$\Delta V_{o1}$	Load regulation <sup>4</sup>	$V_{i\ nom}$	±3		±3		±3		±3			
		$I_o = (0.1\ to\ 1) I_{o\ nom}$										
$V_{o1,2}$	Output voltage noise	$V_{i\ min}$ to $V_{i\ max}$ $I_o = I_{o\ nom}$	80		120		150		240		mV <sub>pp</sub>	
			20	40	25	50	30	60	50	100		
$V_{o\ clip}$	Output overvoltage limit. <sup>7</sup>	Minimum load 1%	115	130	115	130	115	130	115	130	%	
$C_{o\ ext}$	Admissible capacitive load <sup>3</sup>		≤2000		≤300		≤200		≤100		μF	
$V_{o\ d}$	Dynamic load regulat.	Voltage deviat.	±150		±330		±350		±600		mV	
$t_d$		Recovery time	1		1		1		1		ms	
$a_{Vo}$	Temperature coefficient	$V_{i\ min}$ to $V_{i\ max}$ $I_o = 0\ to\ I_{o\ max}$	±0.02		±0.02		±0.02		±0.02		%/K	
		$\Delta V_o / \Delta T_C (T_{C\ min}\ to\ T_{C\ max})$										

<sup>1</sup> Each output is capable of delivering full output power,  $P_{o\ nom}$  according to table: *Model Selection*.

<sup>2</sup> The current limit is primary side controlled.

<sup>3</sup> Measured with both outputs connected in parallel.

<sup>4</sup> Conditions for specified output. Other output loaded with constant current  $I_o = 0.5 I_{o\ nom}$ .

<sup>5</sup> BW = 20 MHz

<sup>6</sup> Measured with a probe according to EN 61204.

<sup>7</sup> The overvoltage protection is not tracking with the R control.

### Short Circuit Behavior

The current limit characteristic shuts down the converter whenever a short circuit is applied to its output. It acts self-protecting and automatically recovers after removal of the overload condition (hiccup mode).

### Thermal Considerations

If a converter, mounted on a pcb, is located in free, quasi-stationary air (convection cooling) at the indicated maximum ambient temperature  $T_{A \max}$  (see table: *Temperature specifications*) and is operated at its nominal input voltage and output power, the case temperature  $T_C$  measured at the *Measuring point of case temperature*  $T_C$  (see: *Mechanical Data*) will approach the indicated value  $T_{C \max}$  after the warm-up phase. However, the relationship between  $T_A$  and  $T_C$  depends heavily on the conditions of operation and integration into a system. The thermal conditions are influenced by input voltage, output current, airflow, temperature of surrounding components and surfaces and the properties of the printed circuit board.  $T_{A \max}$  is therefore only an indicative value and under practical operating conditions, the ambient temperature  $T_A$  may be higher or lower than this value.

**Caution:** The case temperature  $T_C$  measured at the *Measuring point of case temperature*  $T_C$  (see: *Mechanical Data*) may under no circumstances exceed the specified maximum value. The installer must ensure that under all operating conditions  $T_C$  remains within the limits stated in the table: *Temperature specifications*.

### Connection in Series or in Parallel

Connection in series:

The outputs of single or double output units can be connected in series without any precautions, taking into consideration that the highest output voltage should remain below 60 V for SELV operation.

Connection in parallel:

Double outputs of the same converter with equal output voltage (e.g. 5V / 5V) can be put in parallel and will share their output currents almost equally. Parallel operation of single or double outputs of two or more converters with the same output voltage may cause start-up problems at initial start-up. This is only advisable in applications where one converter is able to deliver the full load current as required in true redundant systems.

### Output overvoltage protection

The outputs of single output units and -05-05- types are protected against overvoltages by a second control loop. In the event of an overvoltage on the output the unit will shut-down and attempt to restart approximately every 0.4 seconds. Double output units (with exception of the -05-05- types) are protected against overvoltages by a Zener diode across the second output. Under worst case conditions the Zener diode will short circuit. Since with double output units both outputs track each other the protection diode is only provided in one of the outputs. The main purpose of this feature is to protect against possible overvoltages which could occur due to a failure in the feedback control circuit. The output overvoltage protection is not designed to withstand externally applied overvoltages.

### Typical Performance Curves

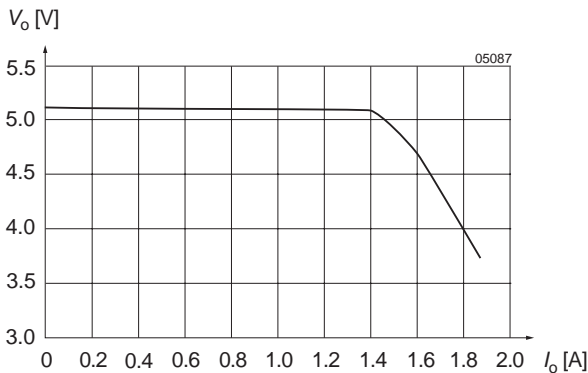

Fig. 6  
 $V_o$  versus  $I_o$  (typ) of single output units with  $V_o = 5.1$  V.

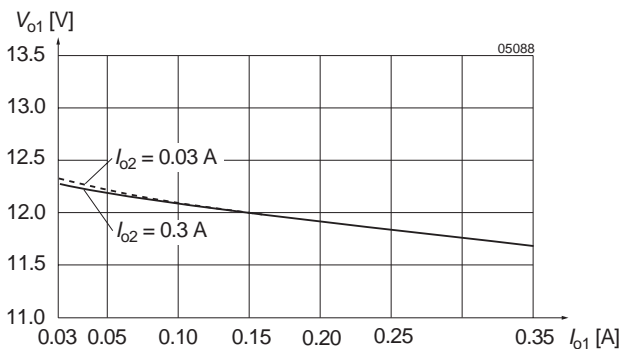

Fig. 8  
 $V_{o1}$  versus  $I_{o1}$  (typ) for various  $I_{o2}$  (2 x 12 V).  
The cross load effect is negligible.

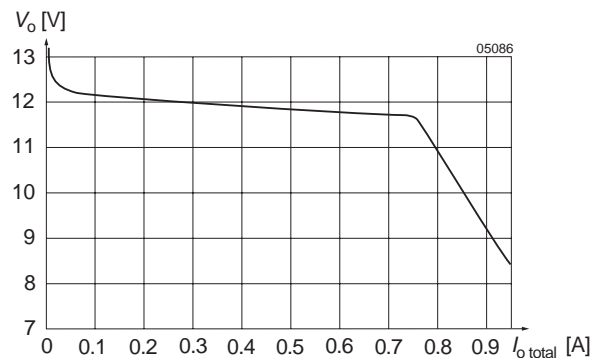

Fig. 7  
 $V_o$  versus  $I_o$  (typ) of double output units, with both outputs in parallel.

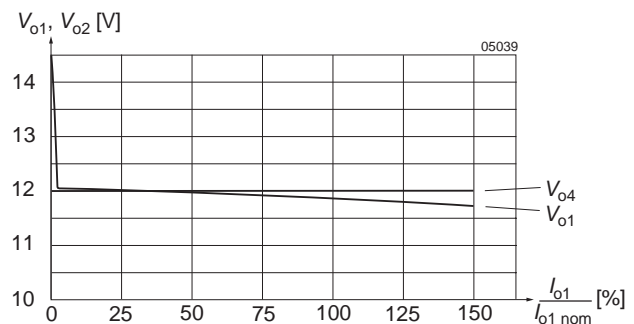

Fig. 9  
Flexible load distribution on double outputs (2 x 12 V) with load variation from 0 to 150% of  $P_{o1 \text{ nom}}$  on output 1. Output 2 loaded with 25% of  $P_{o2 \text{ nom}}$ .



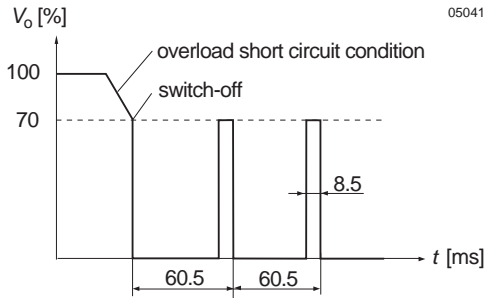

Fig. 10  
Overload switch-off (hiccup mode). Typical values.  
Frequency of pulses: 16.5 Hz, pulse duration: 8.5 ms.

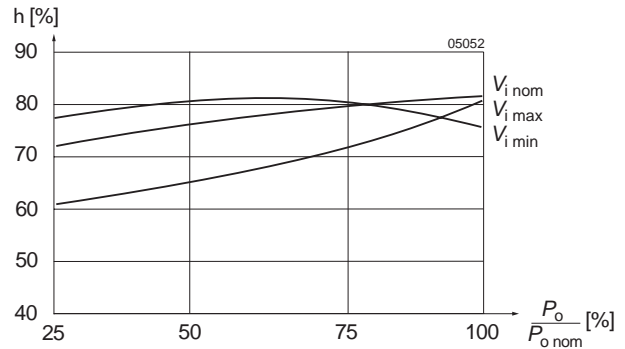

Fig. 11  
Efficiency versus input voltage and load. Typical values  
(40IMX7-12-12).

## Auxiliary Functions

### Inhibit Function

The output(s) of the converter may be enabled or disabled by means of a logic signal (TTL, CMOS, etc.) applied to the inhibit pin. No output voltage overshoot will occur when the unit is turned on. If the inhibit function is not required the inhibit pin should be connected to Vi- to enable the output (active low logic, fail safe).

Converter operating: -10 V to 0.8 V  
 Converter inhibited  
 or inhibit pin left open: 2.4 V to  $V_{i,max}$   
 (<75 V for 70/110IMX7)

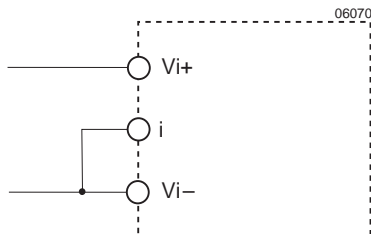

Fig. 12  
If the inhibit is not used the inhibit pin should be connected to Vi-

### Adjustable Output Voltage (R input)

As a standard feature, the IMX7 single and double output units offer adjustable output voltage(s) by using the control input R. If the R pin is left open circuit the output voltage is set to  $V_{o,nom}$ . The output voltage is adjustable in the range 75 to 105% of  $V_{o,nom}$ . The circuit works for single and double output units in a different way. For output voltages  $V_o > V_{o,nom}$ , the minimum input voltage  $V_{i,min}$  (see: *Electrical Input Data*) increases proportionally to  $V_o/V_{o,nom}$ .

#### Single output units:

The R input is referenced to the secondary side of the converter. Adjustment of the output voltage is possible by means of either an external resistor or a voltage source.

#### a) Adjustment by means of an external resistor $R_{ext1}$ :

Depending upon the value of the required output voltage, the resistor shall be connected

**either:** Between the R pin and Vo- to achieve an output voltage adjustment range of approximately

$$V_o = 75 \text{ to } 100\% V_{o,nom}. \text{ (85 to } 100\% \text{ for 3.3 V outputs)}$$

$$R_{ext1} = 4 \text{ k}\Omega \cdot \frac{V_o}{V_{o,nom} - V_o}$$

**or:** Between the R pin and Vo+ to achieve an output voltage range of approximately  $V_o = 100 \text{ to } 105\% V_{o,nom}$ .

$$R_{ext2} = 4 \text{ k}\Omega \cdot \frac{(V_o - 2.5 \text{ V})}{2.5 \text{ V} \cdot (V_o/V_{o,nom} - 1)}$$

b) Adjustment by means of an external voltage  $V_{ext}$  between  $Vo-$  and R pins.

The control voltage range is 1.87 to 2.62 V and allows for an adjustment in the range of approximately 75 to 105%. (85 to 105% for 3.3 V outputs)

$$V_{ext} = \frac{V_o \cdot 2.5 V}{V_{o\ nom}}$$

Attempting to adjust the output below this range will cause the converter to shutdown (hiccup mode).

**Caution:** Applying an external control voltage  $>2.75$  V may damage the converter.

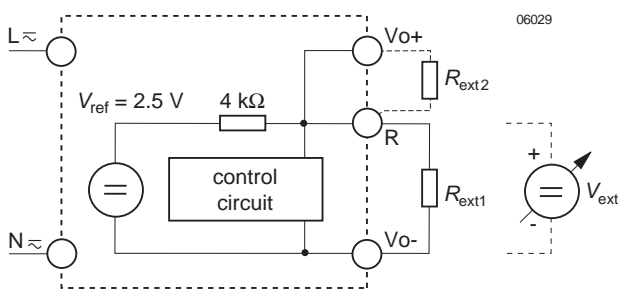

Fig. 13  
Output voltage control for single output units by means of the R-input

**Double output units:**

The R input (Trim) input is referenced to the primary side. The figure below shows the circuit topology. Adjustment of the output voltage is possible by means of either an external resistor in the range of 100 to 105% of  $V_{o\ nom}$ , or an external voltage source in the range of 75 to 105% of  $V_{o\ nom}$ .

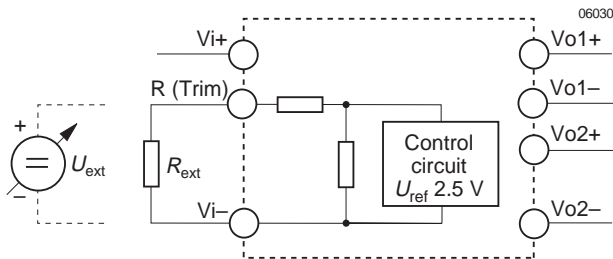

Fig. 14  
Output voltage control for double output units by means of the R input

a) Adjustment by means of an external resistor.

Programming of the output voltage by means of an external resistor  $R_{ext1}$  is possible within a limited range of 100 to 105% of  $V_{o\ nom}$ .  $R_{ext1}$  should be connected between the R-pin and  $Vi-$ . Connection of  $R_{ext1}$  to  $Vi+$  may damage the converter. The following table indicates suitable resistor values for typical output voltages under nominal conditions ( $V_{i\ nom}$ ,  $I_o = 0.5 I_{o\ nom}$ ), with either paralleled outputs or equal load conditions on each output.

Table 6:  $R_{ext1}$  for  $V_o > V_{o\ nom}$ ;  
approximate values ( $V_{i\ nom}$ ,  $I_{o1,2} = 0.5 I_{o1/2\ nom}$ )

$V_o$ [% $V_{o\ nom}$ ]	$R_{ext}$ [kΩ]
105 to 108 (107 typically)	0
105	1.5
104	5.6
103	12
102	27
101	68
100	∞

b) Adjustment by means of an external voltage source  $V_{ext}$ .

For external output voltage programming in the range 75 to 105% of  $V_{o\ nom}$  a (0 to 20 V) source  $V_{ext}$  is required, connected to the R-pin and  $Vi-$ . The table below indicates typical  $V_o$  versus  $V_{ext}$  values under nominal conditions ( $V_{i\ nom}$ ,  $I_o = 0.5 I_{o\ nom}$ ), with either paralleled outputs or equal load conditions on each output. Applying a control voltage greater than 20 V will set the converter into a hiccup mode. Direct paralleling of the R-pins of units connected in parallel is feasible.

Table 7:  $V_{ext}$  for  $V_o = 75$  to 105%  $V_{o\ nom}$ ;  
typical values ( $V_{i\ nom}$ ,  $I_{o1,2} = 0.5 I_{o1/2\ nom}$ )

$V_o$ [% $V_{o\ nom}$ ]	$V_{ext}$ [V]
105	0
102	1.6
95	4.5
85	9
75	13

**Electromagnetic Compatibility (EMC)**

A suppressor diode together with an input filter form an effective protection against high input transient voltages

which typically occur in many installations, but especially in battery-driven mobile applications.

**Electromagnetic Immunity**

Table 8: Immunity type tests

Phenomenon	Standard <sup>1</sup>	Class Level	Coupling mode <sup>2</sup>	Value applied	Waveform	Source Imped.	Test procedure	In oper.	Per- <sup>3</sup> form.
Electrostatic discharge to case	IEC/EN 61000-4-2	2	contact discharge R pin open i pin connec. to Vi-	4000 V <sub>p</sub>	1/50 ns	330 Ω	10 positive and 10 negative discharges	yes	B
		3	air discharge R pin open i pin connec. to Vi-	8000 V <sub>p</sub>					
Electromagnetic field	IEC/EN 61000-4-3	3	antenna	10 V/m	AM 80% 1 kHz	50 Ω	26 to 1000 MHz	yes	A
	ENV 50204				PM, 50% duty cycle, 200 Hz resp. frequ.		900 MHz		
Electrical fast transient/burst	IEC/EN 61000-4-4	4	direct +/-i	4000 V <sub>p</sub>	bursts of 5/50 ns 5 kHz rep. rate transients with 15 ms burst duration and a 300 ms period	50 Ω	1 min positive 1 min negative transients per coupling mode	yes	B
Surge	IEC/EN 61000-4-5 <sup>5</sup>	3	+i/-i	2000 V <sub>p</sub>	1.2/50 μs	2 Ω	5 pos. and 5 neg. impulses per coupling mode	yes	B
Conducted disturbances	IEC/EN 61000-4-6	3	+i/-i	10 V <sub>rms</sub> (140 dBμV)	AM modulated 80%, 1 kHz	50 Ω	0.15 to 80 MHz 150 Ω	yes	A
Transient	19 Pfl 1 <sup>4</sup>		+i/-i	150 V <sub>p</sub>	0.1/0.3 ms	limited to <100 A	3 positive	yes	B

<sup>1</sup> Related and previous standards are referenced in: *Technical Information: Standards.*

<sup>2</sup> i = input, o = output.

<sup>3</sup> A = normal operation, no deviation from specification, B = temporary deviation from specs. possible.

<sup>4</sup> For 40IMX7 types (additional external components required). Not applicable for 20IMX7 types.

<sup>5</sup> External components required.

**Electromagnetic Emission**

Conducted RFI noise at input according to EN 55022

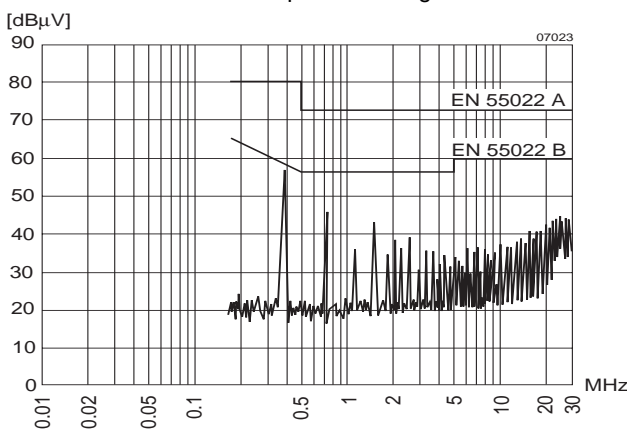

Fig. 15  
Typical disturbance voltage (quasi-peak) at the input according to CISPR 11/EN 55011 and CISPR 22/EN 55022 measured at  $V_{i,nom}$  and  $I_{o,nom}$ . Output leads 0.1 m, twisted. (40IMX7-15-15). External capacitor (1 μF ceramic or film) required at the input for 70IMX7, 110IMX7 types.

Radiated RFI noise according to EN 55022.

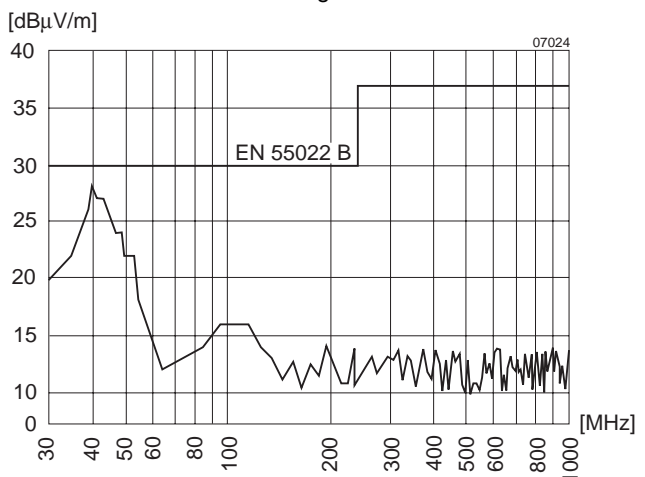

Fig. 16  
Typical radio frequency-interference voltage at  $V_{i,nom}$ ,  $I_{o,nom}$ , measured with an antenna (distance 10 m). Output leads 0.1 m, twisted (70IMX-7-15-15).

**Immunity to Environmental Conditions**

Table 9: Environmental testing

Test Method		Standard	Test Conditions		Status
Ca	Damp heat steady state	IEC/DIN IEC 60068-2-3 MIL-STD-810D section 507.2	Temperature: Relative humidity: Duration:	40 ±2 °C 93 +2/-3 % 56 days	Unit not operating
Ea	Shock (half-sinusoidal)	IEC/EN/DIN EN 60068-2-27 MIL-STD-810D section 516.3	Acceleration amplitude: Bump duration: Number of bumps:	100 g <sub>n</sub> = 981 m/s <sup>2</sup> 6 ms 18 (3 each direction)	Unit operating
Eb	Bump (half-sinusoidal)	IEC/EN/DIN EN 60068-2-29 MIL-STD-810D section 516.3	Acceleration amplitude: Bump duration: Number of bumps:	40 g <sub>n</sub> = 392 m/s <sup>2</sup> 6 ms 6000 (1000 each direction)	Unit operating
Fc	Vibration (sinusoidal)	IEC/EN/DIN EN 60068-2-6	Acceleration amplitude: Frequency (1 Oct/min): Test duration:	0.35 mm (10 to 60 Hz) 5 g <sub>n</sub> = 49 m/s <sup>2</sup> (60 to 2000 Hz) 10 to 2000 Hz 7.5 h (2.5 h each axis)	Unit operating
Fh	Vibration, broad-band random (digital control)	IEC/EN 60068-2-64 MIL-STD-810D section 514.3	Acceleration spectral density: Frequency band: Acceleration magnitude: Test duration:	0.05 g <sub>n</sub> <sup>2</sup> /Hz 20 to 500 Hz 4.9 g <sub>n rms</sub> 3 h (1 h each axis)	Unit operating
Kb	Salt mist, cyclic (sodium chloride NaCl solution)	IEC/EN/DIN IEC 60068-2-52	Concentration: Duration: Storage: Storage duration: Number of cycles:	5% (30°C) 2 h per cycle 40°C, 93% rel. humidity 22 h per cycle 3	Unit not operating

Table 10: Temperature specifications, valid for air pressure of 800 to 1200 hPa (800 to 1200 mbar)

Temperature		Standard -9		Option -8		Unit
Characteristics	Conditions	min	max	min	max	
T <sub>A</sub> Ambient temperature <sup>1</sup>	Operational <sup>2</sup>	-40	71	-40	85	°C
T <sub>C</sub> Case temperature		-40	95	-40	105	
T <sub>S</sub> Storage temperature <sup>1</sup>	Non operational	-40	100	-55	105	

<sup>1</sup> MIL-STD-810D section 501.2 and 502.2

<sup>2</sup> See: *Thermal Considerations*

Table 11: MTBF and device hours

MTBF	Ground Benign	Ground Fixed		Ground Mobile
MTBF acc. to MIL-HDBK-217F	T <sub>C</sub> = 40°C	T <sub>C</sub> = 40°C	T <sub>C</sub> = 70°C	T <sub>C</sub> = 50°C
40IMX7-05-9	1,671,700 h	248,000 h	83,800 h	84,800 h
40IMX7-15-15-9	1,640,000 h	214,000 h	83,000 h	77,000 h

**Mechanical Data**

Dimensions in mm. Tolerances  $\pm 0.3$  mm unless otherwise indicated.

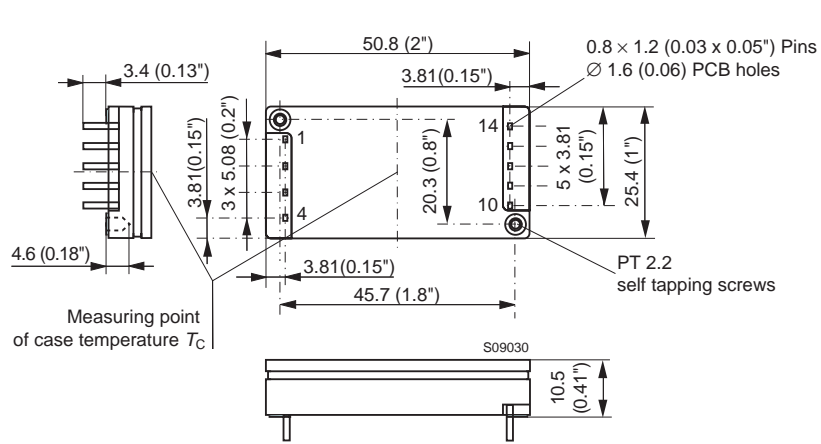

Fig. 17  
Case IMX7 with standard soldering pins  
Weight: <20 g

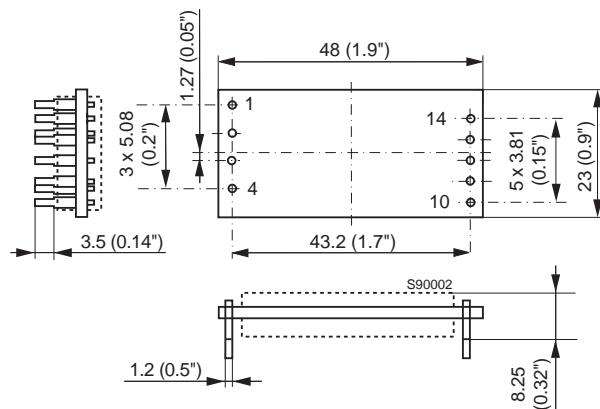

Fig. 18  
Open frame (option Z; NFND)  
Weight: <20 g

Items in yellow or shaded are not recommended for new designs.

### Safety and Installation Instructions

#### Installation Instruction

Installation of the dc-dc converters must strictly follow the national safety regulations in compliance with the enclosure, mounting, creepage, clearance, casualty, markings and segregation requirements of the end-use application.

Connection to the system shall be made via a printed circuit board according to: *Mechanical Data*.

The units should be connected to a secondary circuit.

Check for hazardous voltages before altering any connections.

Do not open the module.

Ensure that a unit failure (e.g. by an internal short-circuit) does not result in a hazardous condition. See also: *Safety of operator accessible output circuit*.

#### Input Fuse

To prevent excessive current flowing through the input supply line in case of a short-circuit across the converter input an external fuse should be installed in a non earthed input supply line. We recommend a fast acting fuse F2A for 20IMX7 and F1A for 40IMX7 and F0.63A for 70/110IMX7 types.

#### Cleaning Agents

In order to avoid possible damage, any penetration of cleaning fluids has to be prevented, since the power supplies are not hermetically sealed.

#### Standards and approvals

All dc-dc converters are pending to be UL recognized according to UL 1950, UL recognized for Canada to CAN/CSA C22.2 No. 950-95 and LGA approved to IEC/EN 60950 standards.

The units have been evaluated for:

- Building in
- Supplementary insulation input to output, based on their maximum input voltage
- The use in a pollution degree 2 environment
- Connecting the input to a secondary circuit which is subject to a maximum transient rating of 1500 V for 20/40IMX7, 2000 V for 70IMX7 and 2500 V for 110IMX7 types.

The dc-dc converters are subject to manufacturing surveillance in accordance with the above mentioned UL, CSA, EN and ISO 9001 standards.

#### Protection Degree

The protection degree of the dc-dc converters is IP 30.

#### Isolation

The electric strength test is performed as factory test in accordance with IEC/EN 60950 and UL 1950 and should not be repeated in the field. Power-One will not honor any guarantee claims resulting from electric strength field tests.

Table 12: Electric strength test voltages

Characteristic	I/O			O/O	Unit
	20/40IMX	70IMX	110IMX		
Electric strength test voltage 1 s	1.2	1.5	2.0	0.1	kV <sub>rms</sub>
	1.5	2.0	2.5	0.15	kV DC
Coupling capacitance	1.2	1.2	1.2	-	nF
Insulation resist. at 500 V DC	>100	>100	>100	-	MΩ
Partial discharge	Consult factory			-	kV

Table 13: Pin allocation, standard pinout

Pin	Single output	Double output
1	Vi+	Vi+
2	Vi-	Vi-
3	i	i
4	n.c.	R (Trim)
10	Vo-	Vo1-
11	Vo+	Vo1+
12	Vo-	Vo2-
13	R	Vo2+
14	n.c.	n.c.



Fig. 19  
Pin allocation standard pinout

**Description of Options**

Table 14: Options

Option	Function	Characteristics
-9	Operational temperature range $T_A = -40$ to $71^\circ\text{C}$	Optional temperature range.
Z	Open Frame	

 Items in yellow or shaded are not recommended for new designs.

NUCLEAR AND MEDICAL APPLICATIONS - Power-One products are not designed, intended for use in, or authorized for use as critical components in life support systems, equipment used in hazardous environments, or nuclear control systems without the express written consent of the respective divisional president of Power-One, Inc.

TECHNICAL REVISIONS - The appearance of products, including safety agency certifications pictured on labels, may change depending on the date manufactured. Specifications are subject to change without notice.