



COM'L MIL

T-46-19-07



PAL22V10-10/15
AmPAL22V10/A
PALCE22V10H-15/25/Q-25
 24-pin TTL/CMOS Versatile PAL® Device

T-46-19-13

**Advanced
 Micro
 Devices**

DISTINCTIVE CHARACTERISTICS

- As fast as 10 ns propagation delay and 71 MHz f_{MAX}
- Low-power EE CMOS versions
- 10 macrocells programmable as registered or combinatorial, and active high or active low to match application needs
- Varied product term distribution allows up to 16 product terms per output for complex functions
- Global asynchronous reset and synchronous preset for initialization
- Power-up reset for initialization and register preload for testability
- Easy design with PALASM® software
- Programmable on standard PAL device programmers
- 24-pin SKIINNYDIP® and 28-pin PLCC packages save space

GENERAL DESCRIPTION

The PAL22V10 provides user-programmable logic for replacing conventional SS/MSI gates and flip-flops at a reduced chip count.

The PAL device implements the familiar Boolean logic transfer function, the sum of products. The PAL device is a programmable AND array driving a fixed OR array. The AND array is programmed to create custom product terms, while the OR array sums selected terms at the outputs.

The product terms are connected to the fixed OR array with a varied distribution from 8 to 16 across the outputs

(see Block Diagram). The OR sum of the products feeds the output macrocell. Each macrocell can be programmed as registered or combinatorial, and active high or active low. The output configuration is determined by two fuses controlling two multiplexers in each macrocell.

The entire PAL device family is supported by the PALASM software package. The PAL family is programmed on conventional PAL device programmers with appropriate personality and socket adapter modules. See the Programmer Reference Guide for approved programmers.



BLOCK DIAGRAM

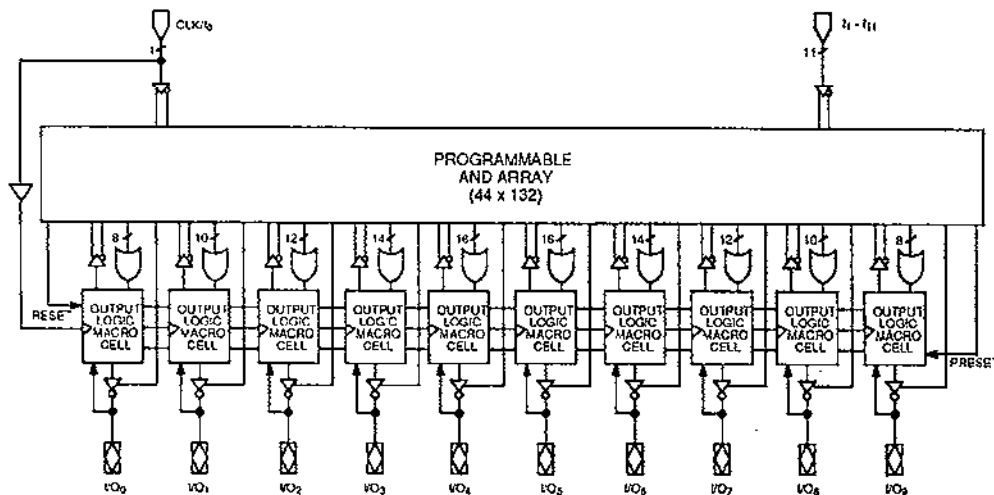

13003-001A

PAL, PALASM, and SKIINNYDIP are registered trademarks of Advanced Micro Devices. This part is covered by various U.S. and foreign patents owned by Advanced Micro Devices.

Publication # 14004 Rev. A Amendment 0
 Issue Date: February 1990

PERFORMANCE OPTIONS

Commercial

T-46-19-07

T-46-19-13

	35			Std
Speed (t _{PD} , ns)	25	CMOS Q-25	CMOS H-25	A
	15		CMOS H-15	-15
	10			-10
		55	90	180

Power (I_{CC}, mA)

OPERATING RANGES

Commercial	Military
-10	-15
-15	-20
A (25 ns)	A (30 ns)
Std (35 ns)	Std (40 ns)
H-15	H-25
H-25	H-30
Q-25	

CONNECTION DIAGRAMS

Top View

T-46-19-07

SKINNYDIP/FLATPACK

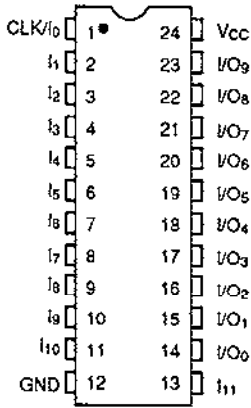

13003-002A

PLCC/LCC

T-46-19-13

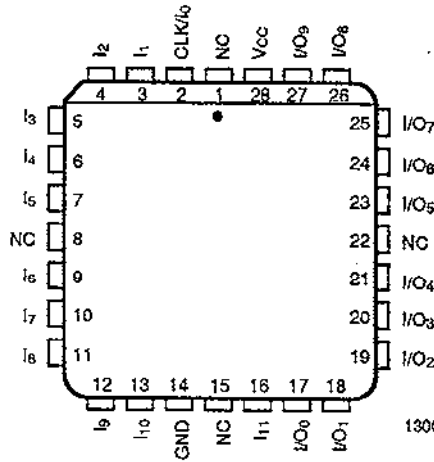

13003-003A



Note:

Pin 1 is marked for orientation.

PIN DESIGNATIONS

CLK	Clock
GND	Ground
I	Input
I/O	Input/Output
NC	No Connect
Vcc	Supply Voltage

ORDERING INFORMATION

Commercial Products

T-46-19-07

T-46-19-7

AMD programmable logic products for commercial applications are available with several ordering options. The order number (Valid Combination) is formed by a combination of:

- a. Family Type
- b. Technology
- c. Number of Array Inputs
- d. Output Type
- e. Number of Outputs
- f. Power
- g. Speed
- h. Package Type
- i. Operating Conditions
- j. Programming Designator

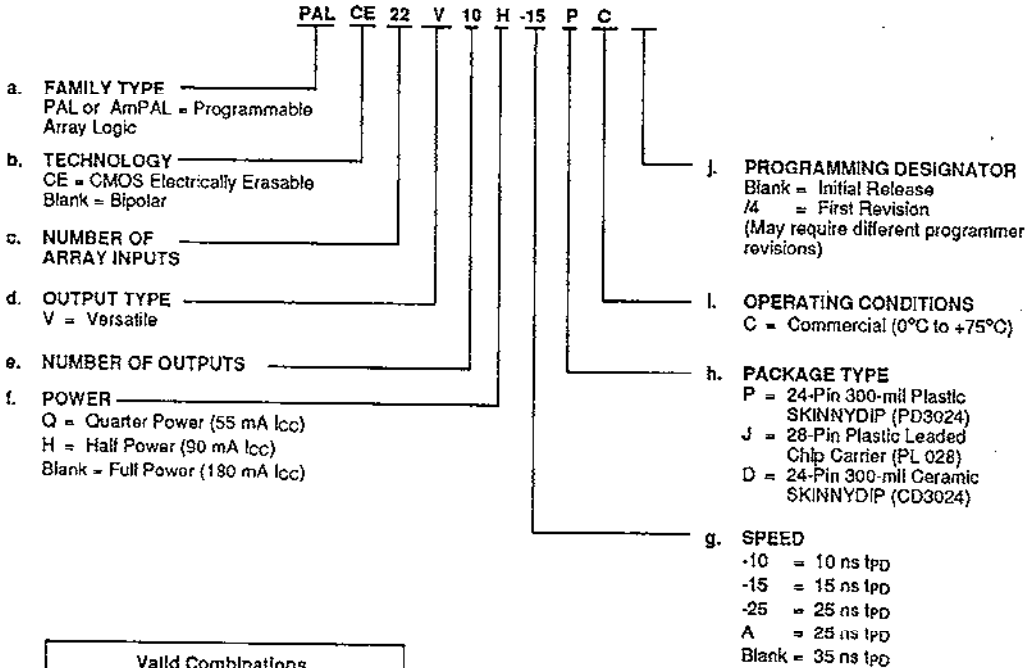

Valid Combinations	
PAL22V10-10	PC, JC, DC
PAL22V10-15	
AmPAL22V10A	
AmPAL22V10	blank, /4
PALCE22V10H-15	
PALCE22V10H-25	
PALCE22V10Q-25	

Valid Combinations

The Valid Combinations table lists configurations planned to be supported in volume for this device. Consult the local AMD sales office to confirm availability of specific valid combinations, to check on newly released combinations, and to obtain additional data on AMD's standard military grade products.

Note: Marked with AMD logo.

T-46-19-07

T-46-19

ORDERING INFORMATION

APL Products

AMD programmable logic products for Aerospace and Defense applications are available with several ordering options. APL (Approved Products List) products are fully compliant with MIL-STD-883 requirements. The order number (Valid Combination) is formed by a combination of:

- a. Family Type
- b. Technology
- c. Number of Array Inputs
- d. Output Type
- e. Number of Outputs
- f. Power
- g. Speed
- h. Programming Designator
- i. Device Class
- j. Package Type
- k. Lead Finish

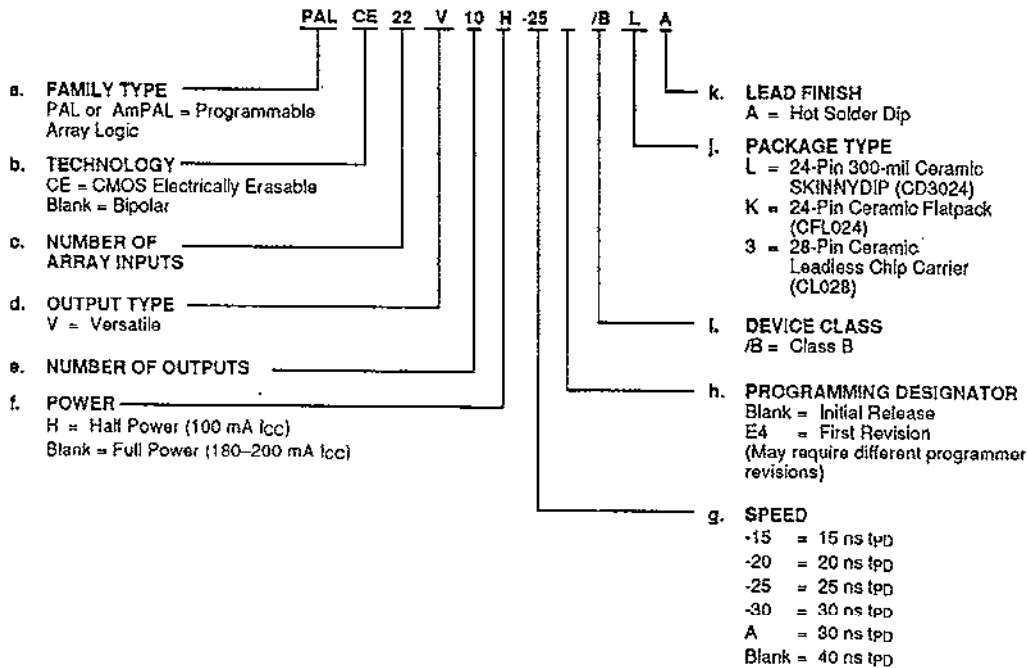

Valid Combinations	
PAL22V10-15	
PAL22V10-20	
AmPAL22V10A	
AmPAL22V10	/B/LA, /BKA, /B3A
PALCE22V10H-25	blank,
PALCE22V10H-30	E4

Valid Combinations

The Valid Combinations table lists configurations planned to be supported in volume for this device. Consult the local AMD sales office to confirm availability of specific valid combinations, to check on newly released combinations, and to obtain additional data on AMD's standard military grade products.

Note: Marked with AMD logo.

Group A Tests

Group A Tests consist of Subgroups: 1, 2, 3, 7, 8, 9, 10, 11.

Military Burn-In

Military burn-in is in accordance with the current revision of MIL-STD-883, Test Methods 1015, Conditions A through E. Test conditions are selected at AMD's option.

T-46-19-07

T-46-1

FUNCTIONAL DESCRIPTION

The PAL22V10 allows the systems engineer to implement the design on-chip, by opening fuse links (or programming EE cells) to configure AND and OR gates within the device, according to the desired logic function. Complex interconnections between gates, which previously required time-consuming layout, are lifted from the PC board and placed on silicon, where they can be easily modified during prototyping or production.

Product terms with all fuses opened assume the logical HIGH state; product terms connected to both true and complement of any single input assume the logical LOW state.

The PAL22V10 has 12 inputs and 10 I/O macrocells (Figure 1). The macrocell allows one of four potential output configurations: registered output or combinatorial I/O, active high or active low (see Figure 2). The configuration choice is made according to the user's design specification and corresponding programming of the configuration bits $S_0 - S_1$. Multiplexer controls are connected to ground (0) through a programmable bit, selecting the "0" path through the multiplexer. Program-

ming the fuse or erasing the bit disconnects the control line from GND and it floats to V_{CC} (1), selecting the "1" path.

The device is produced with a fuse or EE cell link at each input to the AND gate array, and connections may be selectively removed by applying appropriate voltages to the circuit. Utilizing an easily-implemented programming algorithm, these products can be rapidly programmed to any customized pattern. Information on approved programmers can be found in the Programmer Reference Guide. Extra test words are pre-programmed during manufacturing to ensure extremely high field programming yields, and provide extra test paths to achieve excellent parametric correlation.

Variable Input/Output Pin Ratio

The PAL22V10 has twelve dedicated input lines, and each macrocell output can be an I/O pin. Buffers for device inputs have complementary outputs to provide user-programmable input signal polarity. Unused input pins should be tied to V_{CC} or GND.

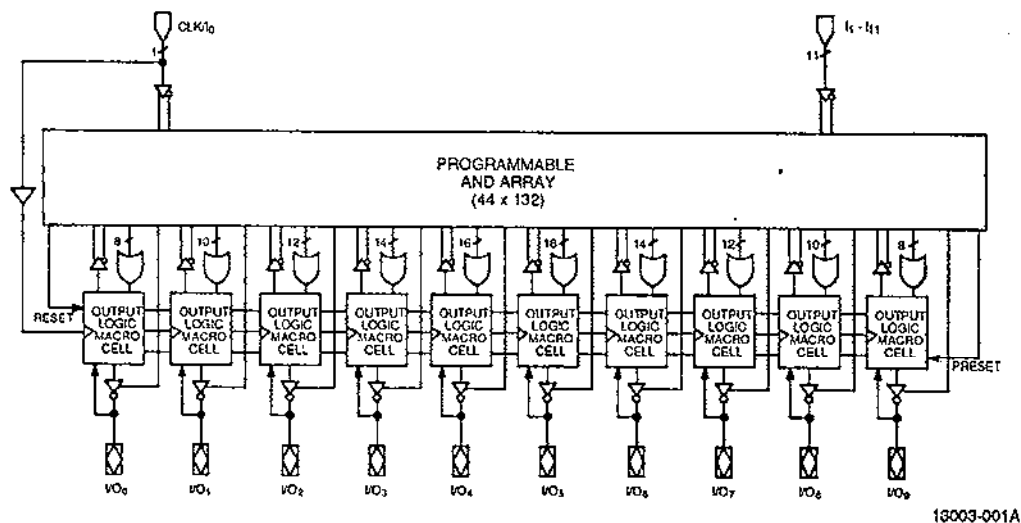

Figure 1. Block Diagram

13003-001A

Registered Output Configuration

Each macrocell of the PAL22V10 includes a D-type flip-flop for data storage and synchronization. The flip-flop is loaded on the LOW-to-HIGH transition of the clock input. In the registered configuration ($S_1 = 0$), the array feedback is from \bar{Q} of the flip-flop.

Combinatorial I/O Configuration

Any macrocell can be configured as combinatorial by selecting the multiplexer path that bypasses the flip-flop ($S_1 = 1$). In the combinatorial configuration the feedback is from the pin.

T-46-19-07

T-46-19-13

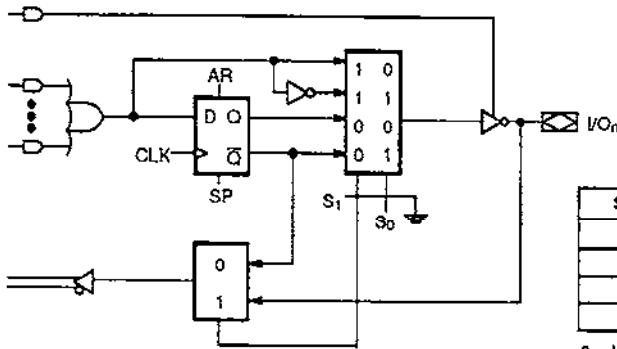

S_1	S_0	Output Configuration
0	0	Registered/Active Low
0	1	Registered/Active High
1	0	Combinatorial/Active Low
1	1	Combinatorial/Active High

0 = Unprogrammed fusa or programmed EE bit
 1 = Programmed fusa or erased (charged) EE bit



13003-004A

Figure 2. Output Logic Macrocell Diagram

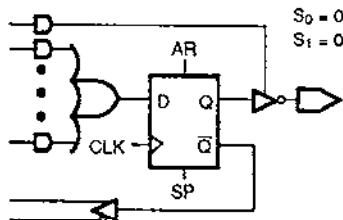

Figure 3a. Registered/Active Low

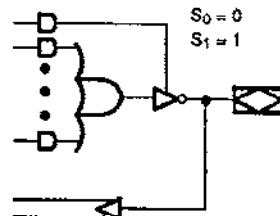

Figure 3c. Combinatorial/Active Low

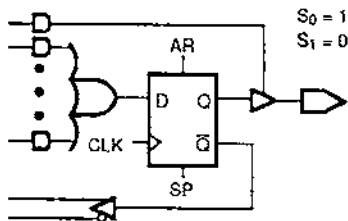

Figure 3b. Registered/Active High

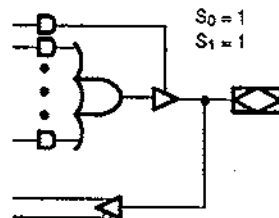

Figure 3d. Combinatorial/Active High

13003-009A

Programmable Three-State Outputs

Each output has a three-state output buffer with three-state control. A product term controls the buffer, allowing enable and disable to be a function of any product of device inputs or output feedback. The combinatorial output provides a bidirectional I/O pin, and may be configured as a dedicated input if the buffer is always disabled.

Programmable Output Polarity

The polarity of each macrocell output can be active high or active low, either to match output signal needs or to reduce product terms. Programmable polarity allows Boolean expressions to be written in their most compact form (true or inverted), and the output can still be of the desired polarity. It can also save "DeMorganizing" efforts.

Selection is controlled by programmable bit S_0 in the output macrocell, and affects both registered and combinatorial outputs. Selection is automatic, based on the design specification and pin definitions. If the pin definition and output equation have the same polarity, the output is programmed to be active high ($S_0 = 1$).

Preset/Reset

For initialization, the PAL22V10 has additional Preset and Reset product terms. These terms are connected to all registered outputs. When the Synchronous Preset (SP) product term is asserted high, the output registers will be loaded with a HIGH on the next LOW-to-HIGH clock transition. When the Asynchronous Reset (AR) product term is asserted high, the output registers will be immediately loaded with a LOW independent of the clock.

Note that preset and reset control the flip-flop, not the output pin. The output level is determined by the output polarity selected.

Power-Up Reset

All flip-flops power-up to a logic LOW for predictable system initialization. Outputs of the PAL22V10 will depend on the programmed output polarity. The V_{CC} rise must be monotonic and the reset delay time is 1–10 μ s maximum.

Register Preload

The register on the PAL22V10 can be preloaded from the output pins to facilitate functional testing of complex state machine designs. This feature allows direct load-

ing of arbitrary states, making it unnecessary to cycle through long test vector sequences to reach a desired state. In addition, transitions from illegal states can be verified by loading illegal states and observing proper recovery.

T-46-19-07

T-46-1

Security Fuse

After programming and verification, a PAL22V10 design can be secured by programming the security fuse or EE bit. Once programmed, this fuse defeats readback of the internal programmed pattern by a device programmer, securing proprietary designs from competitors. When the security fuse is programmed, the array will read as if every fuse is programmed, and preload will be disabled.

For the CMOS PALCE22V10, a floating gate is used as the security bit. The bit can only be erased in conjunction with erasure of the entire pattern.

Quality and Testability

The PAL22V10 offers a very high level of built-in quality. Extra programmable fuses provide a means of verifying performance of all AC and DC parameters. In addition, this verifies complete programmability and functionality of the device to provide the highest programming yields and post-programming functional yields in the industry.

The erasability of the CMOS PALCE22V10 allows direct testing of the device array to guarantee 100% programming and functional yields.

Technology

The bipolar PAL22V10 is fabricated with AMD's advanced oxide-isolated bipolar process. This process reduces parasitic capacitances and minimum geometries to provide higher performance. The array connections are formed with proven PtSi fuses for reliable operation. The PAL22V10-10 uses TiW fuses.

The CMOS PALCE22V10 is fabricated with AMD's advanced EE CMOS process. The array connections are formed by electrically-erasable floating gates similar to those found in EEPROMs.

Programming and Erasing

The PAL22V10 can be programmed on standard logic programmers. Approved programmers are listed in the Programmer Reference Guide.

The CMOS PALCE22V10 may be erased to reset a previously configured device back to its virgin state. Erasure is automatically performed by the programming hardware. No special erase operation is required.

LOGIC DIAGRAM
SKINNYDIP (PLCC/LCC) Pinouts

T-46-19-07

T-46-19-13

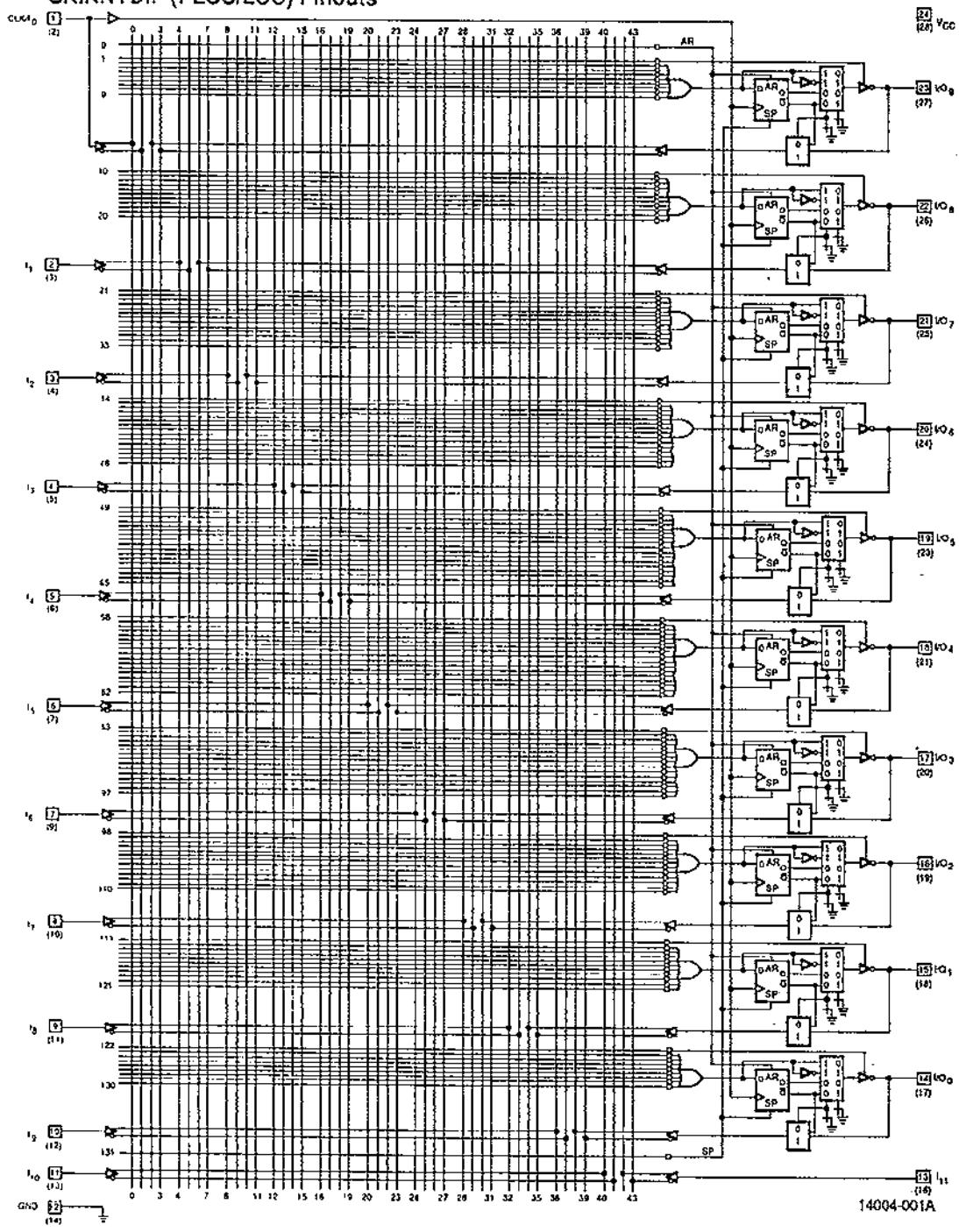

14004-001A

ABSOLUTE MAXIMUM RATINGS

Storage Temperature	-65°C to +150°C
Ambient Temperature with Power Applied	-55°C to +125°C
Supply Voltage with Respect to Ground	-0.5 V to +7.0 V
DC Input Voltage (-10)	-1.2 V to $V_{CC} + 0.5$ V
DC Input Voltage (-15)	-0.5 V to $V_{CC} + 0.5$ V
DC Input Current (-15)	-30 mA to +5 mA
DC Output or I/O Pin Voltage	-0.5 V to $V_{CC} + 0.5$ V
Static Discharge Voltage	2001 V

OPERATING RANGES**Commercial (C) Devices**

Ambient Temperature (T_A)	0°C to +75°C
Operating in Free Air	
Supply Voltage (V_{CC}) with Respect to Ground	+4.75 V to +5.25 V

T-46-19-07

T-46-1

Operating ranges define those limits between which the functionality of the device is guaranteed.

Stresses above those listed under Absolute Maximum Ratings may cause permanent device failure. Functionality at or above these limits is not implied. Exposure to Absolute Maximum Ratings for extended periods may affect device reliability. Programming conditions may differ.

DC CHARACTERISTICS over COMMERCIAL operating ranges unless otherwise specified

Parameter Symbol	Parameter Description	Test Conditions	Min.	Max.	Unit
V_{OH}	Output HIGH Voltage	$I_{OH} = -3.2$ mA $V_{IN} = V_{IH}$ or V_{IL} $V_{CC} = \text{Min.}$	2.4		V
V_{OL}	Output LOW Voltage	$I_{OL} = 16$ mA $V_{IN} = V_{IH}$ or V_{IL} $V_{CC} = \text{Min.}$		0.5	V
V_{IH}	Input HIGH Voltage	Guaranteed Input Logical HIGH Voltage for all Inputs (Note 1)	2.0		V
V_{IL}	Input LOW Voltage	Guaranteed Input Logical LOW Voltage for all Inputs (Note 1)		0.8	V
V_I	Input Clamp Voltage	$I_{IN} = -18$ mA, $V_{CC} = \text{Min.}$		-1.2	V
I_{IH}	Input HIGH Current	$V_{IN} = 2.7$ V, $V_{CC} = \text{Max.}$ (Note 2)		25	μ A
I_{IL}	Input LOW Current	$V_{IN} = 0.4$ V, $V_{CC} = \text{Max.}$ (Note 2)		-100	μ A
I_I	Maximum Input Current	$V_{IN} = 5.5$ V, $V_{CC} = \text{Max.}$		1	mA
I_{OZH}	Off-State Output Leakage Current HIGH	$V_{OUT} = 2.7$ V, $V_{CC} = \text{Max.}$ $V_{IN} = V_{IH}$ or V_{IL} (Note 2)		100	μ A
I_{OZL}	Off-State Output Leakage Current LOW	$V_{OUT} = 0.4$ V, $V_{CC} = \text{Max.}$ $V_{IN} = V_{IH}$ or V_{IL} (Note 2)		-100	μ A
I_{SC}	Output Short-Circuit Current	$V_{OUT} = 0.5$ V, $V_{CC} = \text{Max.}$ (Note 3)	-30	-90	mA
I_{CC}	Supply Current	$V_{IN} = 0$ V, Outputs Open ($I_{OUT} = 0$ mA) $V_{CC} = \text{Max.}$		180	mA

Notes:

- These are absolute values with respect to device ground and all overshoots due to system and/or tester noise are included.
- I/O pin leakage is the worst case of I_{IL} and I_{OZL} (or I_{IH} and I_{OZH}).
- Not more than one output should be tested at a time. Duration of the short-circuit should not exceed one second. $V_{OUT} = 0.5$ V has been chosen to avoid test problems caused by tester ground degradation.

CAPACITANCE (Note 1)

T-46-19-07

T-46-19-13

Parameter Symbol	Parameter Description	Test Conditions	-10	-15	Unit	
			Typ.	Typ.		
C _{IN}	Input Capacitance	Pins 1, 13 Others	V _{IN} = 2.0 V	V _{CC} = 5.0 V	T _A = 25°C	pF
C _{OUT}	Output Capacitance	V _{OUT} = 2.0 V	f = 1 MHz	8	9	

Notes:

1. These parameters are not 100% tested, but are evaluated at initial characterization and at any time the design is modified where capacitance may be affected.

SWITCHING CHARACTERISTICS over COMMERCIAL operating ranges (Note 2)

PRELIMINARY

Parameter Symbol	Parameter Description	-10		-15		Unit
		Min. (Note 3)	Max.	Min.	Max.	
t _{FD}	Input or Feedback to Combinatorial Output	3	10		15	ns
t _S	Setup Time from Input, Feedback or SP to Clock	8		10		ns
t _H	Hold Time	0		0		ns
t _{CO}	Clock to Output	3	6		10	ns
t _{CF}	Clock to Feedback (Note 4)		2.5		2.5	ns
t _{AR}	Asynchronous Reset to Registered Output		15		20	ns
t _{ARW}	Asynchronous Reset Width	10		15		ns
t _{ARR}	Asynchronous Reset Recovery Time	8		10		ns
t _{SPR}	Synchronous Preset Recovery Time	8		10		ns
t _{WL}	Clock Width	LOW	5	6		ns
		HIGH	5	6		ns
f _{MAX}	Maximum Frequency (Note 5)	External Feedback	1/(t _S + t _{CO})	71	50	MHz
		Internal Feedback	1/(t _S + t _{CF})	95	80	MHz
		No Feedback	1/(t _{WH} + t _{WL})	100	83	MHz
t _{EA}	Input to Output Enable Using Product Term Control	3	10		15	ns
t _{ER}	Input to Output Disable Using Product Term Control	3	10		15	ns

Notes:

2. See Switching Test Circuit for test conditions.
3. Output delay minimums are measured under best-case conditions.
4. Calculated from measured f_{MAX} internal.
5. These parameters are not 100% tested, but are calculated at initial characterization and at any time the design is modified where frequency may be affected.

ABSOLUTE MAXIMUM RATINGS

Storage Temperature	-65°C to +150°C
Supply Voltage with Respect to Ground	-0.5 V to +7.0 V
DC Input Voltage (-15)	-1.2 V to +7.0 V
DC Input Voltage (-20)	-0.5 V to +5.5 V
DC Output or I/O Pin Voltage	-0.5 V to +7.0 V
DC Input Current (-20)	-30 mA to +5 mA

Stresses above those listed under Absolute Maximum Ratings may cause permanent device failure. Functionality at or above these limits is not implied. Exposure to Absolute Maximum Ratings for extended periods may affect device reliability. Programming conditions may differ. Absolute Maximum Ratings are for system design reference; parameters given are not tested.

OPERATING RANGES

Military (M) Devices (Note 1)	T-46-19-07
Ambient Temperature (T _A)	
Operating in Free Air	-55°C Min.
Operating Case (T _C) Temperature	125°C Max.
Supply Voltage (V _{CC}) with Respect to Ground	+4.50 V to +5.50 V

Operating ranges define those limits between which the functionality of the device is guaranteed.

Note:

- Military products are tested at T_C = +25°C, +125°C, and -55°C, per MIL-STD-883.

DC CHARACTERISTICS over MILITARY operating ranges unless otherwise specified (Note 2)

Parameter Symbol	Parameter Description	Test Conditions	Min.	Max.	Unit
V _{OH}	Output HIGH Voltage	I _{OH} = -2 mA V _{IN} = V _{IH} or V _{IL} V _{CC} = Min.	2.4		V
V _{OL}	Output LOW Voltage	I _{OL} = 12 mA V _{IN} = V _{IH} or V _{IL} V _{CC} = Min.		0.5	V
V _{IH}	Input HIGH Voltage	Guaranteed Input Logical HIGH Voltage for all Inputs (Note 3)	2.0		V
V _{IL}	Input LOW Voltage	Guaranteed Input Logical LOW Voltage for all Inputs (Note 3)		0.8	V
V _I	Input Clamp Voltage	I _{IN} = -18 mA, V _{CC} = Min.		-1.2	V
I _{IH}	Input HIGH Current	V _{IN} = 2.7 V, V _{CC} = Max. (Note 4)		25	μA
I _{IL}	Input LOW Current	V _{IN} = 0.4 V, V _{CC} = Max. (Note 4)		-100	μA
I _I	Maximum Input Current	V _{IN} = 5.5 V, V _{CC} = Max.		1	mA
I _{OZH}	Off-State Output Leakage Current HIGH	V _{OUT} = 2.7 V, V _{CC} = Max. V _{IN} = V _{IH} or V _{IL} (Note 4)		100	μA
I _{OZL}	Off-State Output Leakage Current LOW	V _{OUT} = 0.4 V, V _{CC} = Max. V _{IN} = V _{IH} or V _{IL} (Note 4)		-100	μA
I _{sc}	Output Short-Circuit Current	V _{OUT} = 0.5 V, V _{CC} = Max. (Note 5)	-30	-90	mA
I _{CC}	Supply Current	V _{IN} = 0 V, Outputs Open (I _{OUT} = 0 mA) V _{CC} = Max.		200	mA

Notes:

- For APL Products, Group A, Subgroups 1, 2, and 3 are tested per MIL-STD-883, Method 5005, unless otherwise noted.
- V_{IL} and V_{IH} are input conditions of output tests and are not themselves directly tested. V_{IL} and V_{IH} are absolute voltages with respect to device ground and include all overshoots due to system and/or tester noise. Do not attempt to test these values without suitable equipment.
- I/O pin leakage is the worst case of I_{IL} and I_{OZL} (or I_{IH} and I_{OZH}).
- Not more than one output should be tested at a time. Duration of the short-circuit should not exceed one second. V_{OUT} = 0.5 V has been chosen to avoid test problems caused by tester ground degradation.

CAPACITANCE (Note 1)

T-46-19-07

T-46-19-13

Parameter Symbol	Parameter Description	Test Conditions	-15	-20	Unit
			Typ.	Typ.	
C _{IN}	Input Capacitance	V _{IN} = 2.0 V V _{CC} = 5.0 V T _A = 25°C	6	9	pF
				Others	
C _{OUT}	Output Capacitance	V _{OUT} = 2.0 V f = 1 MHz	8	9	

Note:

1. These parameters are not 100% tested, but are evaluated at initial characterization and at any time the design is modified where capacitance may be affected.

SWITCHING CHARACTERISTICS over MILITARY operating ranges (Note 2)

PRELIMINARY

Parameter Symbol	Parameter Description	-15		-20		Unit
		Min.	Max.	Min.	Max.	
t _{PD}	Input or Feedback to Combinatorial Output		15		20	ns
t _S	Setup Time from Input, or Feedback to Clock	10		17		ns
t _H	Hold Time	0		0		ns
t _{CO}	Clock to Output		10		15	ns
t _{CF}	Clock to Feedback (Note 3 and 4)		2.5		13	ns
t _{AR}	Asynchronous Reset to Registered Output		20		25	ns
t _{ARW}	Asynchronous Reset Width (Note 5)	15		20		ns
t _{ARR}	Asynchronous Reset Recovery Time (Note 5)	10		20		ns
t _{SPR}	Synchronous Preset Recovery Time (Note 4)	10		20		ns
t _{WL}	Clock Width	LOW		6	15	ns
		HIGH		6	15	ns
f _{MAX}	Maximum Frequency (Note 6)	External Feedback	1/(t _S + t _{CO})	50	31.2	MHz
		Internal Feedback	1/(t _S + t _{CF})	80	33.3	MHz
t _{EA}	Input to Output Enable Using Product Term Control (Note 4)		15		20	ns
t _{ER}	Input to Output Disable Using Product Term Control (Note 4)		15		20	ns

Notes:

2. See Switching Test Circuit for test conditions. For APL products Group A, Subgroups 9, 10, and 11 are tested per MIL-STD-883, Method 5005, unless otherwise noted.
3. Calculated from measured f_{MAX} internal.
4. These parameters are not 100% tested, but are evaluated at initial characterization and at any time the design is modified where these parameters may be affected.
5. t_{ARW} and t_{ARR} are not directly tested, but are guaranteed by the testing of t_S and t_{AR}.
6. These parameters are not 100% tested, but are calculated at initial characterization and at any time the design is modified where frequency may be affected.

ABSOLUTE MAXIMUM RATINGS

Storage Temperature	-65°C to +150°C
Ambient Temperature with Power Applied	-55°C to +125°C
Supply Voltage with Respect to Ground	-0.5 V to +7.0 V
DC Input Voltage	-0.5 V to +5.5 V
DC Input Current	-30 mA to +5 mA
DC Output or I/O Pin Voltage	-0.5 V to V _{CC} Max.

OPERATING RANGES

Commercial (C) Devices

Ambient Temperature (T _A)	
Operating in Free Air	0°C to +75°C
Supply Voltage (V _{CC}) with Respect to Ground	+4.75 V to +5.25 V

T-46-19-07

T-46-19-13

Operating ranges define those limits between which the functionality of the device is guaranteed.

Stresses above those listed under Absolute Maximum Ratings may cause permanent device failure. Functionality at or above these limits is not implied. Exposure to Absolute Maximum Ratings for extended periods may affect device reliability. Programming conditions may differ.

DC CHARACTERISTICS over COMMERCIAL operating ranges unless otherwise specified

Parameter Symbol	Parameter Description	Test Conditions	Min.	Max.	Unit
V _{OH}	Output HIGH Voltage	I _{OH} = -3.2 mA V _{IN} = V _{IH} or V _{IL} V _{CC} = Min.	2.4		V
V _{OL}	Output LOW Voltage	I _{OL} = 16 mA V _{IN} = V _{IH} or V _{IL} V _{CC} = Min.		0.5	V
V _{IH}	Input HIGH Voltage	Guaranteed Input Logical HIGH Voltage for all Inputs (Note 1)	2.0		V
V _{IL}	Input LOW Voltage	Guaranteed Input Logical LOW Voltage for all Inputs (Note 1)		0.8	V
V _I	Input Clamp Voltage	I _{IN} = -18 mA, V _{CC} = Min.		-1.2	V
I _{IH}	Input HIGH Current	V _{IN} = 2.7 V, V _{CC} = Max. (Note 2)		25	μA
I _{IL}	Input LOW Current	V _{IN} = 0.4 V, V _{CC} = Max. (Note 2)		-100	μA
I _I	Maximum Input Current	V _{IN} = 5.5 V, V _{CC} = Max.		1	mA
I _{OZH}	Off-State Output Leakage Current HIGH	V _{OUT} = 2.7 V, V _{CC} = Max. V _{IN} = V _{IH} or V _{IL} (Note 2)		100	μA
I _{OZL}	Off-State Output Leakage Current LOW	V _{OUT} = 0.4 V, V _{CC} = Max. V _{IN} = V _{IH} or V _{IL} (Note 2)		-100	μA
I _{sc}	Output Short-Circuit Current	V _{OUT} = 0.5 V, V _{CC} = Max. (Note 3)	-30	-90	mA
I _{CC}	Supply Current	V _{IN} = 0 V, Outputs Open (I _{OUT} = 0 mA) V _{CC} = Max.		180	mA

Notes:

1. These are absolute values with respect to device ground and all overshoots due to system and/or tester noise are included.
2. I/O pin leakage is the worst case of I_{IL} and I_{OZL} (or I_{IH} and I_{OZH}).
3. Not more than one output should be tested at a time. Duration of the short-circuit should not exceed one second. V_{OUT} = 0.5 V has been chosen to avoid test problems caused by tester ground degradation.

CAPACITANCE (Note 1)

T-46-19-07

T-46-19-13

Parameter Symbol	Parameter Description	Test Conditions	Typ.	Unit
C _{IN}	Input Capacitance	V _{IN} = 2.0 V V _{CC} = 5.0 V T _A = 25°C f = 1 MHz	11	pF
			6	
C _{OUT}	Output Capacitance	V _{OUT} = 2.0 V	9	

Note:

1. These parameters are not 100% tested, but are evaluated at initial characterization and at any time the design is modified where capacitance may be affected.

SWITCHING CHARACTERISTICS over COMMERCIAL operating ranges (Note 2)

Parameter Symbol	Parameter Description	A		Std.		Unit
		Min.	Max.	Min.	Max.	
t _{FD}	Input or Feedback to Combinatorial Output		25		35	ns
t _S	Setup Time from Input, Feedback or SP to Clock	20		30		ns
t _H	Hold Time	0		0		ns
t _{CO}	Clock to Output or Feedback		15		25	ns
t _{AR}	Asynchronous Reset to Registered Output		30		40	ns
t _{ARW}	Asynchronous Reset Width	25		35		ns
t _{ARR}	Asynchronous Reset Recovery Time	25		35		ns
t _{SPR}	Synchronous Preset/Recovery Time	20		30		ns
t _{WL}	Clock Width	LOW	15	25		ns
		HIGH	15	25		ns
f _{MAX}	Maximum Frequency (Note 3)	External Feedback	1/(t _S + t _{CO})	28.5	18	MHz
t _{EA}	Input to Output Enable Using Product Term Control		25		35	ns
t _{ER}	Input to Output Disable Using Product Term Control		25		35	ns

2

Notes:

2. See Switching Test Circuit for test conditions.
3. These parameters are not 100% tested, but are calculated at initial characterization and at any time the design is modified where frequency may be affected.

ABSOLUTE MAXIMUM RATINGS

Storage Temperature	-65°C to +150°C
Supply Voltage with Respect to Ground	-0.5 V to +7.0 V
DC Input Voltage	-0.5 V to +5.5 V
DC Output or I/O Pin Voltage	-0.5 V to V_{CC} Max.
DC Input Current	-30 mA to +5 mA
Output Sink Current	100 mA (Note 6)

Stresses above those listed under Absolute Maximum Ratings may cause permanent device failure. Functionality at or above these limits is not implied. Exposure to Absolute Maximum Ratings for extended periods may affect device reliability. Programming conditions may differ. Absolute Maximum Ratings are for system design reference; parameters given are not tested.

OPERATING RANGES

Military (M) Devices (Note 1)	
Ambient Temperature (T_A)	
Operating in Free Air	-55°C Min.
Operating Case (T_C) Temperature	+125°C Max.
Supply Voltage (V_{CC}) with Respect to Ground	+4.50 V to +5.50 V

Operating ranges define those limits between which the functionality of the device is guaranteed.

Note:

- Military products are tested at $T_C = +25^\circ\text{C}$, $+125^\circ\text{C}$ and -55°C per MIL-STD-883.

DC CHARACTERISTICS over MILITARY operating ranges unless otherwise specified (Note 2)

Parameter Symbol	Parameter Description	Test Conditions	Min.	Max.	Unit
V_{OH}	Output HIGH Voltage	$I_{OH} = -2$ mA $V_{IN} = V_{IH}$ or V_{IL} $V_{CC} = \text{Min.}$	2.4		V
V_{OL}	Output LOW Voltage	$I_{OL} = 12$ mA $V_{IN} = V_{IH}$ or V_{IL} $V_{CC} = \text{Min.}$		0.5	V
V_{IH}	Input HIGH Voltage	Guaranteed Input Logical HIGH Voltage for all inputs (Note 3)	2.0		V
V_{IL}	Input LOW Voltage	Guaranteed Input Logical LOW Voltage for all inputs (Note 3)		0.8	V
V_{IC}	Input Clamp Voltage	$I_{IN} = -18$ mA, $V_{CC} = \text{Min.}$		-1.2	V
I_{IH}	Input HIGH Current	$V_{IN} = 2.7$ V, $V_{CC} = \text{Max.}$ (Note 4)		25	μA
I_{IL}	Input LOW Current	$V_{IN} = 0.4$ V, $V_{CC} = \text{Max.}$ (Note 4)		-100	μA
I_I	Maximum Input Current	$V_{IN} = 5.5$ V, $V_{CC} = \text{Max.}$		1	mA
I_{OZH}	Off-State Output Leakage Current HIGH	$V_{OUT} = 2.7$ V, $V_{CC} = \text{Max.}$ $V_{IN} = V_{IH}$ or V_{IL} (Note 4)		100	μA
I_{OZL}	Off-State Output Leakage Current LOW	$V_{OUT} = 0.4$ V, $V_{CC} = \text{Max.}$ $V_{IN} = V_{IH}$ or V_{IL} (Note 4)		-100	μA
I_{SC}	Output Short-Circuit Current	$V_{OUT} = 0.5$ V, $V_{CC} = \text{Max.}$ (Note 5)	-30	-90	mA
I_{CC}	Supply Current	$V_{IN} = 0$ V, Outputs Open ($I_{OUT} = 0$ mA) $V_{CC} = \text{Max.}$		180	mA

Notes:

- For APL Products, Group A, Subgroups 1, 2, and 3 are tested per MIL-STD-883, Method 5005, unless otherwise noted.
- V_{IL} and V_{IH} are input conditions of output tests and are not themselves directly tested. V_{IL} and V_{IH} are absolute voltages with respect to device ground and include all overshoots due to system and/or tester noise. Do not attempt to test these values without suitable equipment.
- I/O pin leakage is the worst case of I_{IL} and I_{OZL} (or I_{IH} and I_{OZH}).
- Not more than one output should be tested at a time. Duration of the short-circuit should not exceed one second. $V_{OUT} = 0.5$ V has been chosen to avoid test problems caused by tester ground degradation.
- Not more than one output should sink 100 mA at a time. Duration should not exceed one second.

CAPACITANCE (Note 1)

T-46-19-07

T-46-19-1

Parameter Symbol	Parameter Description	Test Conditions	Typ.	Unit	
C _{IN}	Input Capacitance	V _{IN} = 2.0 V	V _{CC} = 5.0 V	11	pF
			T _A = 25°C	6	
C _{OUT}	Output Capacitance	V _{OUT} = 2.0 V	f = 1 MHz	9	

Note:

1. These parameters are not 100% tested, but are evaluated at initial characterization and at any time the design is modified where capacitance may be affected.

SWITCHING CHARACTERISTICS over MILITARY operating ranges (Note 2)

Parameter Symbol	Parameter Description	A		Src.		Unit	
		Min.	Max.	Min.	Max.		
t _{PO}	Input or Feedback to Combinatorial Output		30		40	ns	
t _S	Setup Time from Input, or Feedback to Clock	25		35		ns	
t _H	Hold Time	0		0		ns	
t _{CO}	Clock to Output or Feedback		20		25	ns	
t _{AR}	Asynchronous Reset to Registered Output		35		45	ns	
t _{ARW}	Asynchronous Reset Width (Note 3)	30		40		ns	
t _{ARR}	Asynchronous Reset Recovery Time (Note 3)	30		40		ns	
t _{WL}	Clock Width	LOW	20	30		ns	
		HIGH	20	30		ns	
f _{MAX}	Maximum Frequency (Note 4)	External Feedback		1/(t _S + t _{CO})	22	16.5	MHz
t _{EA}	Input to Output Enable Using Product Term Control (Note 5)		30		40	ns	
t _{ED}	Input to Output Disable Using Product Term Control (Note 5)		30		40	ns	

Notes:

2. See Switching Test Circuit for test conditions.
3. t_{ARW} and t_{ARR} are not directly tested, but are guaranteed by the testing of t_S and t_{AR}.
4. These parameters are not 100% tested, but are calculated at initial characterization and at any time the design is modified where frequency may be affected.
5. These parameters are not 100% tested, but are evaluated at initial characterization and at any time the design is modified where these parameters may be affected.

ABSOLUTE MAXIMUM RATINGS

Storage Temperature	-65°C to +150°C
Ambient Temperature with Power Applied	-55°C to +125°C
Supply Voltage with Respect to Ground	-0.5 V to +7.0 V
DC Input Voltage (Except Pin 5)	-0.5 V to $V_{CC} + 0.5$ V
DC Input Voltage (Pin 5)	-0.6 V to +11.0 V
DC Output or I/O Pin Voltage	-0.5 V to $V_{CC} + 0.5$ V
Static Discharge Voltage	2001 V
Latchup Current ($T_A = 0^\circ\text{C}$ to $+75^\circ\text{C}$)	100 mA

Stresses above those listed under Absolute Maximum Ratings may cause permanent device failure. Functionality at or above these limits is not implied. Exposure to Absolute Maximum Ratings for extended periods may affect device reliability. Programming conditions may differ.

OPERATING RANGES

Commercial (C) Devices		T-46-19-07	T-46-19-
Ambient Temperature (T_A)	Operating in Free Air	0°C to +75°C	
Supply Voltage (V_{CC}) with Respect to Ground (Except H-25)		+4.75 V to +5.25 V	
Supply Voltage (V_{CC}) with Respect to Ground (H-25)		+4.5 V to +5.5 V	

Operating Ranges define those limits between which the functionality of the device is guaranteed.

DC CHARACTERISTICS over COMMERCIAL operating ranges unless otherwise specified

Parameter Symbol	Parameter Description	Test Conditions	Min.	Max.	Unit
V_{OH}	Output HIGH Voltage	$I_{OH} = -3.2$ mA $V_{IN} = V_{IH}$ or V_{IL} $V_{CC} = \text{Min.}$	2.4		V
V_{OL}	Output LOW Voltage	$I_{OL} = 16$ mA $V_{IN} = V_{IH}$ or V_{IL} $V_{CC} = \text{Min.}$		0.4	V
V_{IH}	Input HIGH Voltage	Guaranteed Input Logical HIGH Voltage for all Inputs (Note 1)	2.0		V
V_{IL}	Input LOW Voltage	Guaranteed Input Logical LOW Voltage for all Inputs (Note 1)		0.8	V
I_{IH}	Input HIGH Leakage Current	$V_{IN} = 5.5$ V, $V_{CC} = \text{Max.}$ (Note 2)		10	μA
I_{IL}	Input LOW Leakage Current	$V_{IN} = 0$ V, $V_{CC} = \text{Max.}$ (Note 2)		-10	μA
I_{OZH}	Off-State Output Leakage Current HIGH	$V_{OUT} = 5.5$ V, $V_{CC} = \text{Max.}$, $V_{IN} = V_{IL}$ or V_{IH} (Note 2)		10	μA
I_{OZL}	Off-State Output Leakage Current LOW	$V_{OUT} = 0$ V, $V_{CC} = \text{Max.}$, $V_{IN} = V_{IL}$ or V_{IH} (Note 2)		-10	μA
I_{SC}	Output Short-Circuit Current	$V_{OUT} = 0.5$ V, $V_{CC} = \text{Max.}$ (Note 3)	-30	-150	mA
I_{CC}	Supply Current	$V_{IN} = 0$ V, Outputs Open ($I_{OUT} = 0$ mA), $V_{CC} = \text{Max.}$	H	90	mA
			Q	55	

Notes:

- These are absolute values with respect to the device ground and all overshoots due to system and tester noise are included.
- I/O pin leakage is the worst case of I_{IL} and I_{OZL} (or I_{IH} and I_{OZH}).
- Not more than one output should be tested at a time. Duration of the short-circuit test should not exceed one second. $V_{OUT} = 0.5$ V has been chosen to avoid test problems caused by tester ground degradation.

CAPACITANCE (Note 1)

T-46-19-07

T-46-19-1

Parameter Symbol	Parameter Description	Test Conditions		Typ.	Unit
C_{IN}	Input Capacitance	$V_{IN} = 2.0\text{ V}$	$V_{CC} = 5.0\text{ V}$ $T_A = 25^\circ\text{C}$ $f = 1\text{ MHz}$	6	pF
C_{OUT}	Output Capacitance	$V_{OUT} = 2.0\text{ V}$		8	

Note:

1. These parameters are not 100% tested, but are evaluated at initial characterization and at any time the design is modified where capacitance may be affected.

SWITCHING CHARACTERISTICS over COMMERCIAL operating ranges (Note 2)

Parameter Symbol	Parameter Description	-15		-25		Unit
		Min.	Max.	Min.	Max.	
t_{PD}	Input or Feedback to Combinatorial Output		15		25	ns
t_s	Setup Time from Input, Feedback or SP to Clock	10		15		ns
t_H	Hold Time	0		0		ns
t_{CO}	Clock to Output		10		15	ns
t_{CF}	Clock to Feedback (Note 3)		7		13	ns
t_{AR}	Asynchronous Reset to Registered Output		20		25	ns
t_{ARW}	Asynchronous Reset Width	15		25		ns
t_{ARR}	Asynchronous Reset Recovery Time	10		25		ns
t_{SPR}	Synchronous Preset Recovery Time	10		25		ns
t_{WL}	Clock Width	LOW		8	13	ns
t_{WH}		HIGH		8	13	ns
f_{MAX}	Maximum Frequency (Note 4)	External Feedback	$1/(t_s + t_{CO})$	50	33.3	MHz
		Internal Feedback	$1/(t_s + t_{CF})$	58.8	35.7	MHz
t_{EA}	Input to Output Enable Using Product Term Control		15		25	ns
t_{ER}	Input to Output Disable Using Product Term Control		15		25	ns

Notes:

2. See Switching Test Circuit for test conditions.
3. Calculated from measured f_{MAX} internal.
4. These parameters are not 100% tested, but are calculated at initial characterization and at any time the design is modified where frequency may be affected.

ABSOLUTE MAXIMUM RATINGS

Storage Temperature	-65°C to +150°C
Ambient Temperature with Power Applied	-55°C to +125°C
Supply Voltage with Respect to Ground	-0.5 V to +7.0 V
DC Input Voltage (Except Pin 5)	-0.5 V to $V_{CC} + 0.5$ V
DC Input Voltage (Pin 5)	-0.6 V to +11.0 V
DC Output or I/O Pin Voltage	-0.5 V to $V_{CC} + 0.5$ V
Static Discharge Voltage	2001 V
Latchup Current ($T_A = -55^\circ\text{C}$ to $+125^\circ\text{C}$)	100 mA

Stresses above those listed under Absolute Maximum Ratings may cause permanent device failure. Functionality at or above these limits is not implied. Exposure to Absolute Maximum Ratings for extended periods may affect device reliability. Programming conditions may differ. Absolute Maximum Ratings are for system design reference; parameters given are not tested.

OPERATING RANGES

Military (M) Devices (Note 1)	T-46-19-07
Operating Case Temperature (T_C)	-55°C to +125°C
Supply Voltage (V_{CC}) with Respect to Ground	+4.5 V to +5.5 V

Operating ranges define those limits between which the functionality of the device is guaranteed.

Note:

1. Military products are tested at $T_C = +25^\circ\text{C}$, $+125^\circ\text{C}$ and -55°C , per MIL-STD-883.

DC CHARACTERISTICS over MILITARY operating ranges unless otherwise specified (Note 2)

Parameter Symbol	Parameter Description	Test Conditions	Min.	Max.	Unit
V_{OH}	Output HIGH Voltage	$I_{OH} = -2.0$ mA $V_{IN} = V_{IH}$ or V_{IL} $V_{CC} = \text{Min.}$	2.4		V
V_{OL}	Output LOW Voltage	$I_{OL} = 12$ mA $V_{IN} = V_{IH}$ or V_{IL} $V_{CC} = \text{Min.}$		0.4	V
V_{IH}	Input HIGH Voltage	Guaranteed Input Logical HIGH Voltage for all inputs (Note 3)	2.0		V
V_{IL}	Input LOW Voltage	Guaranteed Input Logical LOW Voltage for all inputs (Note 3)		0.8	V
I_{IH}	Input HIGH Leakage Current	$V_{IN} = 5.5$ V, $V_{CC} = \text{Max.}$ (Note 4)		10	μA
I_{IL}	Input LOW Leakage Current	$V_{IN} = 0$ V, $V_{CC} = \text{Max.}$ (Note 4)		-10	μA
I_{OZH}	Off-State Output Leakage Current HIGH	$V_{OUT} = 5.5$ V, $V_{CC} = \text{Max.}$ $V_{IN} = V_{IH}$ or V_{IL} (Note 4)		10	μA
I_{OZL}	Off-State Output Leakage Current LOW	$V_{OUT} = 0$ V, $V_{CC} = \text{Max.}$ $V_{IN} = V_{IH}$ or V_{IL} (Note 4)		-10	μA
I_{SC}	Output Short-Circuit Current	$V_{OUT} = 0.5$ V $V_{CC} = \text{Max.}$ (Note 5)	-30	-150	mA
I_{CC}	Supply Current	$V_{IN} = 0$ V, Outputs Open ($I_{OUT} = 0$ mA), $V_{CC} = \text{Max.}$		100	mA

Notes:

2. For APL products, Group A, Subgroups 1, 2 and 3 are tested per MIL-STD-883, Method 5005, unless otherwise noted.
3. V_{IL} and V_{IH} are input conditions of output tests and are not themselves directly tested. V_{IL} and V_{IH} are absolute voltages with respect to device ground and include all overshoots due to system and/or tester noise. Do not attempt to test these values without suitable equipment.
4. I/O pin leakage is the worst case of I_{IL} and I_{OZL} (or I_{IH} and I_{OZH}).
5. Not more than one output should be shorted at a time and duration of the short-circuit should not exceed one second. $V_{OUT} = 0.5$ V has been chosen to avoid test problems caused by tester ground degradation. This parameter is not 100% tested, but is evaluated at initial characterization and at any time the design is modified where I_{SC} may be affected.

CAPACITANCE (Note 1)

T-46-19-07

T-46-19-

Parameter Symbol	Parameter Description	Test Conditions		Typ.	Unit
C _{IN}	Input Capacitance	V _{IN} = 2.0 V	V _{CC} = 5.0 V T _A = 25°C	8	pF
C _{OUT}	Output Capacitance	V _{OUT} = 2.0 V	f = 1 MHz	9	

Note:

1. These parameters are not 100% tested, but are evaluated at initial characterization and at any time the design is modified where capacitance may be affected.

SWITCHING CHARACTERISTICS over MILITARY operating ranges (Note 2)

Parameter Symbol	Parameter Description	-25		-30		Unit
		Min.	Max.	Min.	Max.	
t _{PD}	Input or Feedback to Combinational Output		25		30	ns
t _S	Setup Time from Input, Feedback or SP to Clock	20		20		ns
t _H	Hold Time (Note 4)	0		0		ns
t _{CO}	Clock to Output		20		20	ns
t _{CF}	Clock to Feedback (Note 3)		18		18	ns
t _{AR}	Asynchronous Reset to Registered Output		30		35	ns
t _{ARW}	Asynchronous Reset Width (Note 4)	25		30		ns
t _{ARR}	Asynchronous Reset Recovery Time (Note 4)	25		30		ns
t _{SPR}	Synchronous Preset Recovery Time	25		30		ns
t _{WL}	Clock Width	LOW	15	15		ns
		HIGH	15	15		ns
f _{MAX}	Maximum Frequency (Note 5)	External Feedback	1/(t _S + t _{CO})	25	25	MHz
		Internal Feedback	1/(t _S + t _{CF})	26	26	MHz
t _{EA}	Input to Output Enable Using Product Term Control (Note 4)		25		30	ns
t _{ED}	Input to Output Disable Using Product Term Control (Note 4)		25		30	ns



Notes:

2. See Switching Test Circuit for test conditions. For APL products Group A, Subgroups 7, 8, 9, 10, and 11 are tested per MIL-STD-883, Method 5005, unless otherwise noted.
3. Calculated from measured f_{MAX} internal.
4. These parameters are not 100% tested, but are evaluated at initial characterization and at any time the design is modified where these parameters may be affected.
5. These parameters are not 100% tested, but are calculated at initial characterization and at any time the design is modified where frequency may be affected.

T-46-19-07

T-46-19-1

SWITCHING WAVEFORMS

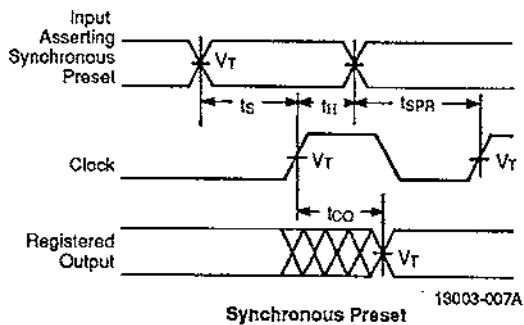
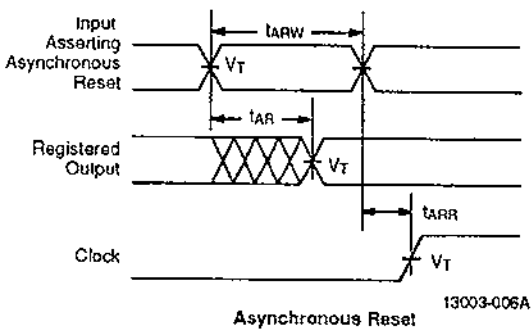
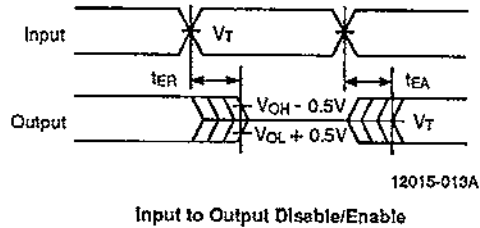
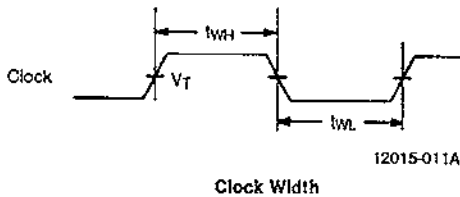
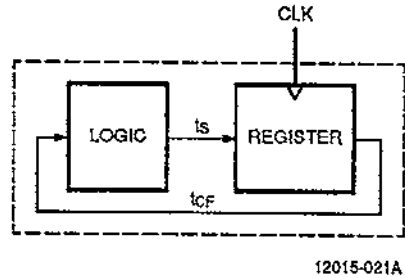
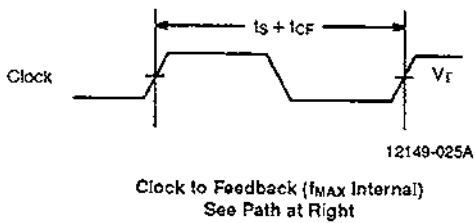
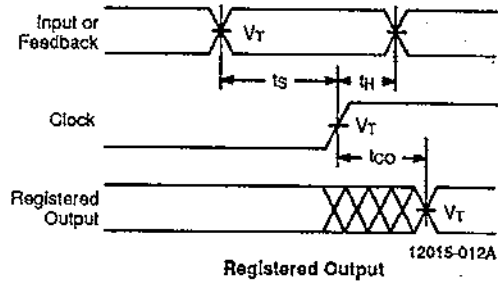
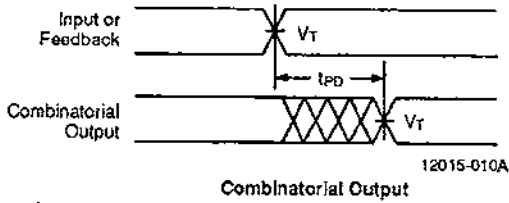



Notes:

1. $V_T = 1.5$ V.
2. Input pulse amplitude 0 V to 3.0 V.
3. Input rise and fall times 2-5 ns typical. (2-4 ns for 22V10-10)

KEY TO SWITCHING WAVEFORMS

T-46-19-07

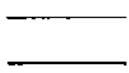
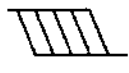
T-46-19-13

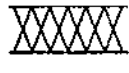
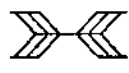
WAVEFORM	INPUTS	OUTPUTS
	Must be Steady	Will be Steady
	May Change from H to L	Will be Changing from H to L
	May Change from L to H	Will be Changing from L to H
	Don't Care; Any Change Permitted	Changing, State Unknown
	Does Not Apply	Center Line is High-Impedance "Off" State

KS000010-PAL



SWITCHING TEST CIRCUIT

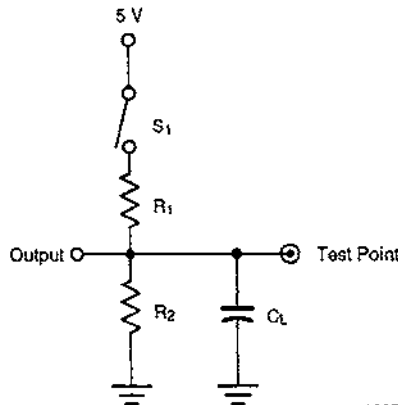

12950-019A

Specification	S ₁	C _L	Commercial		Military		Measured Output Value
			R ₁	R ₂	R ₁	R ₂	
t _{PD} , t _{CO} , t _{CF}	Closed	50 pF	300 Ω	390 Ω	390 Ω	750 Ω	1.5 V
t _{EA}	Z → H: Open Z → L: Closed				CMOS: 338 Ω	CMOS: 248 Ω	1.5 V
t _{ER}	H → Z: Open L → Z: Closed	5 pF					H → Z: V _{OH} - 0.5 V L → Z: V _{OL} + 0.5 V

INPUT/OUTPUT EQUIVALENT SCHEMATICS
Bipolar Devices Only

T-46-19-07

T-46-19-13

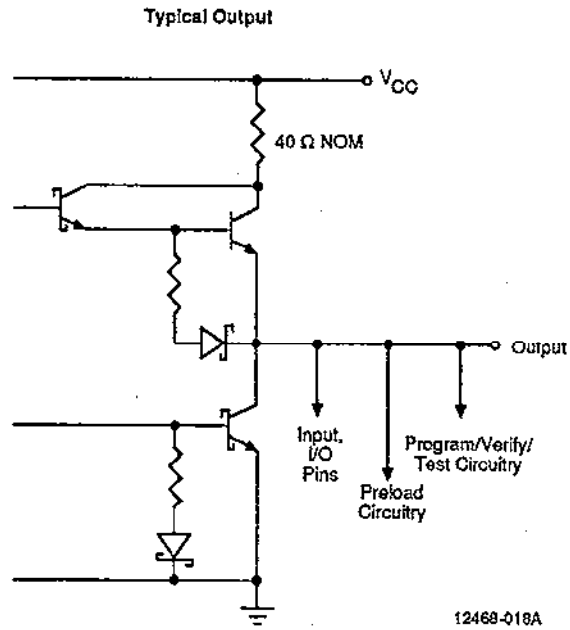
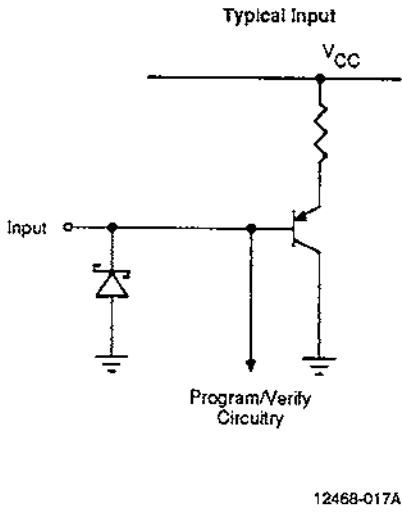

ENDURANCE CHARACTERISTICS

The PALCE22V10 is manufactured using AMD's advanced Electrically Erasable process. This technology uses an EE cell to replace the fuse link used in bipolar

parts. As a result, the device can be erased and reprogrammed – a feature which allows 100% testing at the factory.

Endurance Characteristics

Symbol	Parameter	Min.	Units	Test Conditions
t _{OR}	Min. Pattern Data Retention Time	10	Years	Max. Storage Temperature
		20	Years	Max. Operating Temperature (Military)
N	Min. Reprogramming Cycles	100	Cycles	Normal Programming Conditions

INPUT/OUTPUT EQUIVALENT SCHEMATICS
CMOS Devices Only

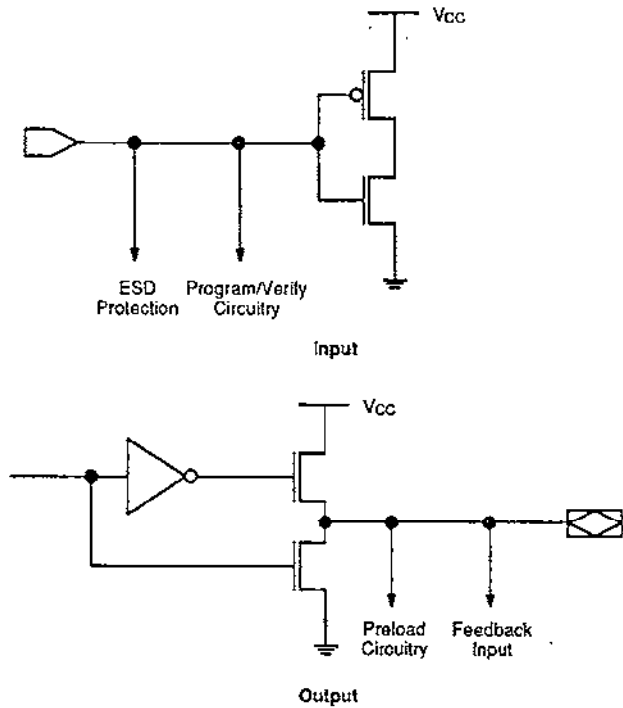

2

12197-013A

OUTPUT REGISTER PRELOAD

T-46-19-07

T-46-19-

Bipolar Devices Only

The preload function allows the registers to be loaded from the output pins. This feature aids functional testing of sequential designs by allowing direct setting of output states. The procedure for preloading follows.

1. Raise V_{CC} to $5.0\text{ V} \pm 0.5\text{ V}$.
2. Set pins 2 and 3 (and 13 for AmPAL22V10/A) to V_{HH} to disable outputs and enable preload.
3. Apply the desired value (V_{ILP}/V_{IHP}) to all registered output pins. Leave combinatorial output pins floating.
4. Clock pin 1 from V_{ILP} to V_{IHP} .
5. Remove V_{ILP}/V_{IHP} from all registered output pins.
6. Lower pins 2 and 3 to V_{ILP} .
7. Enable the output registers according to the programmed pattern.
8. Verify V_{OL}/V_{OH} at all registered output pins. Note that the output pin signal will depend on the output polarity.

Parameter Symbol	Parameter Description	Min.	Rec.	Max.	Unit
V_{HH}	Super-level input voltage	10	11	12	V
V_{ILP}	Low-level input voltage	0	0	0.5	V
V_{IHP}	High-level input voltage	2.4	5.0	5.5	V
t_D	Delay time	100	200	1000	ns

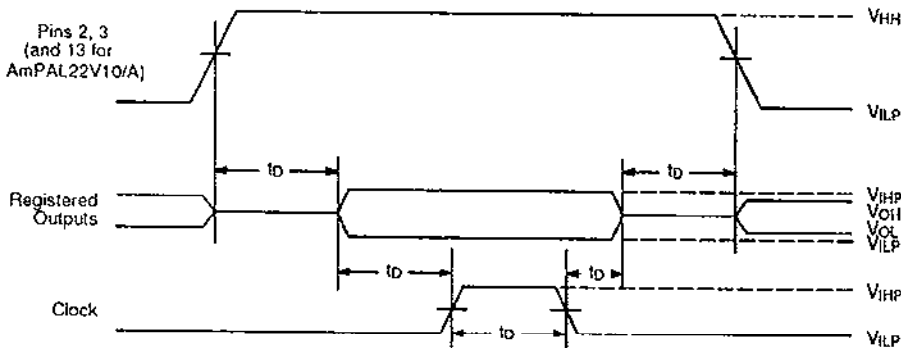

14004-002A

Output Register Preload Waveform

OUTPUT REGISTER PRELOAD

CMOS Devices Only

The preload function allows the registers to be loaded from the output pins. This feature aids functional testing of sequential designs by allowing direct setting of output states. The procedure for preloading follows.

1. Raise V_{CC} to $5.0\text{ V} \pm 0.5\text{ V}$.
2. Set pin 5 to V_{HH} to disable outputs and enable preload.
3. Apply the desired value (V_{ILP}/V_{IHP}) to all registered output pins. Leave combinatorial output pins floating.
4. Clock pin 1 from V_{ILP} to V_{IHP} .
5. Remove V_{ILP}/V_{IHP} from all registered output pins.
6. Lower pin 5 to V_{ILP} .
7. Enable the output registers according to the programmed pattern.
8. Verify V_{OL}/V_{OH} at all registered output pins. Note that the output pin signal will depend on the output polarity.

Parameter Symbol	Parameter Description	Min.	Rec.	Max.	Unit
V_{HH}	Super-level input voltage	9.5	10	10.5	V
V_{ILP}	Low-level input voltage	0	0	0.5	V
V_{IHP}	High-level input voltage	3.0	4.0	V_{CC}	V
t_{PLD}	Setup and Hold Data to Preload (Pin 5)	50	50		μs
t_{PSU}	Data Setup Prior to Applying Preload Latch Pulse	1.0	1.0*		μs
t_{PDH}	Data Hold After Latch Pulse	1.0	1.0*		μs
t_{PH}	Mode Hold After Latch Pulse	1.0	1.0*		μs
t_{PW}	Latch Pulse Width	1.0	1.0*		μs
t_{VO}	I/O Valid After Pin 5 Drops from V_{HH} to TTL Levels			100	μs
$\frac{dV_r}{dt}$	V_{HH} Rising Slew Rate (Pin 5)	10		100	V/ μs
$\frac{dV_f}{dt}$	V_{HH} Falling Slew Rate (Pin 5)		2.0	3.0	V/ μs

* Recommended value is as close to $1.0\ \mu\text{s}$ + tolerance as practical, but not less than $1.0\ \mu\text{s}$.

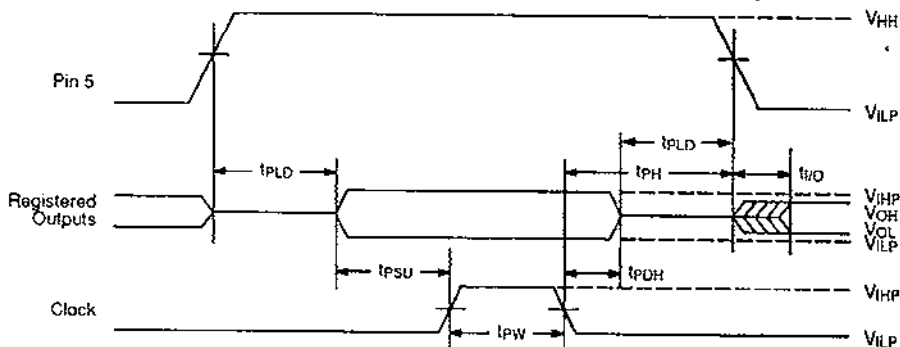

14004-003A

Output Register Preload Waveform

POWER-UP RESET

The power-up reset feature ensures that all flip-flops will be reset to LOW after the device has been powered up. The output state will depend on the programmed pattern. This feature is valuable in simplifying state machine initialization. A timing diagram and parameter table are shown below. Due to the synchronous operation of the power-up reset and the wide range of ways V_{CC}

can rise to its steady state, two conditions are required to ensure a valid power-up reset. These conditions are:

1. The V_{CC} rise must be monotonic.
2. Following reset, the clock input must not be driven from LOW to HIGH until all applicable input and feedback setup times are met.

Parameter Symbol	Parameter Description		Max.	Unit
t_{PR}	Power-up Reset Time	Bipolar	1	μs
		CMOS	10	
t_s	Input or Feedback Setup Time	See Switching Characteristics		
t_{WL}	Clock Width LOW			

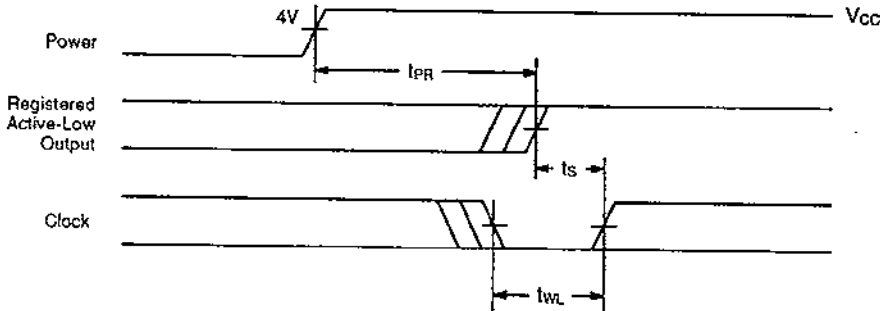

12350-024A

Power-Up Reset Waveform