

# SIEMENS

## Microcomputer Components

8-Bit CMOS Microcontroller

C511/C511A

C513/C513A

C513A-H

<b>Data Sheet C511/C511A/C513/C513A/C513A-H</b>	
<b>Revision History :                      Current Version : 06.96</b>	
Previous Releases :                      02.96, 05.95	
Page	Subjects (changes since last revision)
Several 41	Corrections of text Figure 22: external clock configuration corrected

## 8-Bit CMOS Microcontroller Family

**C511  
C511A  
C513  
C513A  
C513A-H**

### Preliminary

- Fully software compatible to standard 8051/8052 microcontrollers
- Up to 12 MHz operating frequency
- Up to 12 K×8 ROM / EEPROM
- Up to 256×8 RAM
- Up to 256 x 8 XRAM
- Four 8-bit ports
- Up to three 16-bit Timers / Counters (Timer 2 with Up/Down and 16-bit Autoreload Feature)
- Synchronous Serial Channel (SSC)
- Optional USART
- Up to seven interrupt sources, two priority levels
- Power Saving Modes
- P-LCC-44 package (C513A also in P-MQFP-44 package)
- Temperature Ranges : SAB-C511 / 511A / 513 / 513A / C513A-H  $T_A$  : 0 °C to 70 °C  
SAF-C513A  $T_A$  : -40 °C to 85 °C

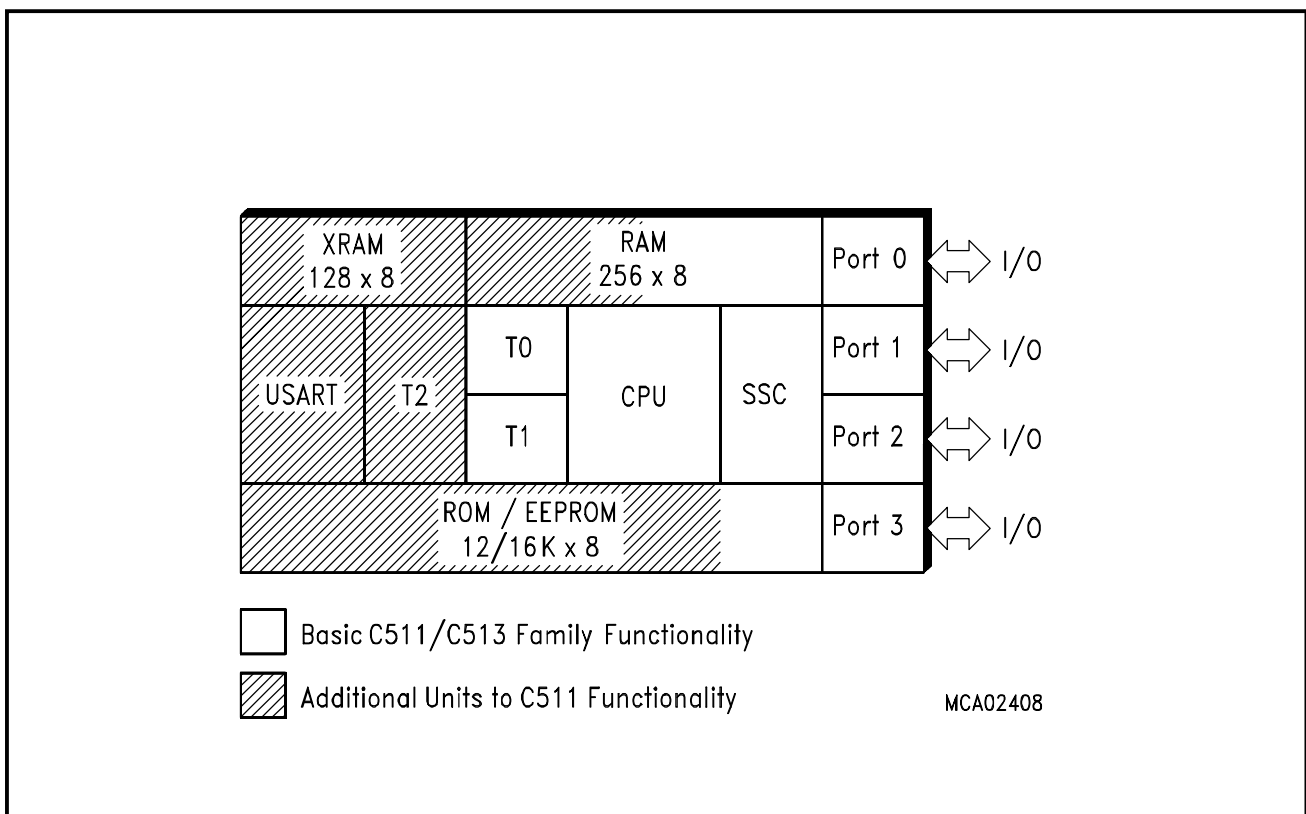

The C511, C511A, C513, C513A, and C513A-H are members of a family of low cost micro-controllers, which are software compatible with the components of the SAB 8051, SAB 80C51 and C500 families.

The first four versions contains a non-volatile read-only (ROM) program memory. The C513A-H is a version with a 12 Kbyte EEPROM instead of ROM. This device can be used for prototype designs which have a demand for reprogrammable on-chip code memory.

The members of the microcontroller family differ in functionality according **table 1**. They offer different ROM sizes, different RAM/XRAM sizes and a different timer/USART configuration. Common to all devices is an advanced SSC serial port, a second synchronous serial interface, which is compatible to the SPI serial bus industry standard. The functionality of the C513A-H is a superset of all ROM versions of the C511/C513 family.

**Table 1**  
**Functionality of the C511/C513 MCUs**

Device	ROM Size	EEPROM Size	RAM Size	XRAM Size	Timers <sup>1)</sup>	USART	SSC
C511	2.5 KB	–	128 B	–	T0, T1	–	✓
C511A	4 KB	–	256 B	–	T0, T1	–	✓
C513	8 KB	–	256 B	–	T0, T1, T2	✓	✓
C513A	12, 16 KB	–	256 B	256 B	T0, T1, T2	✓	✓
C513A-H	–	12 KB	256 B	256 B	T0, T1, T2	✓	✓

1) T0/T1 refers to the standard 8051 timer 0/1 units, T2 refers to the 8052 timer 2 unit.

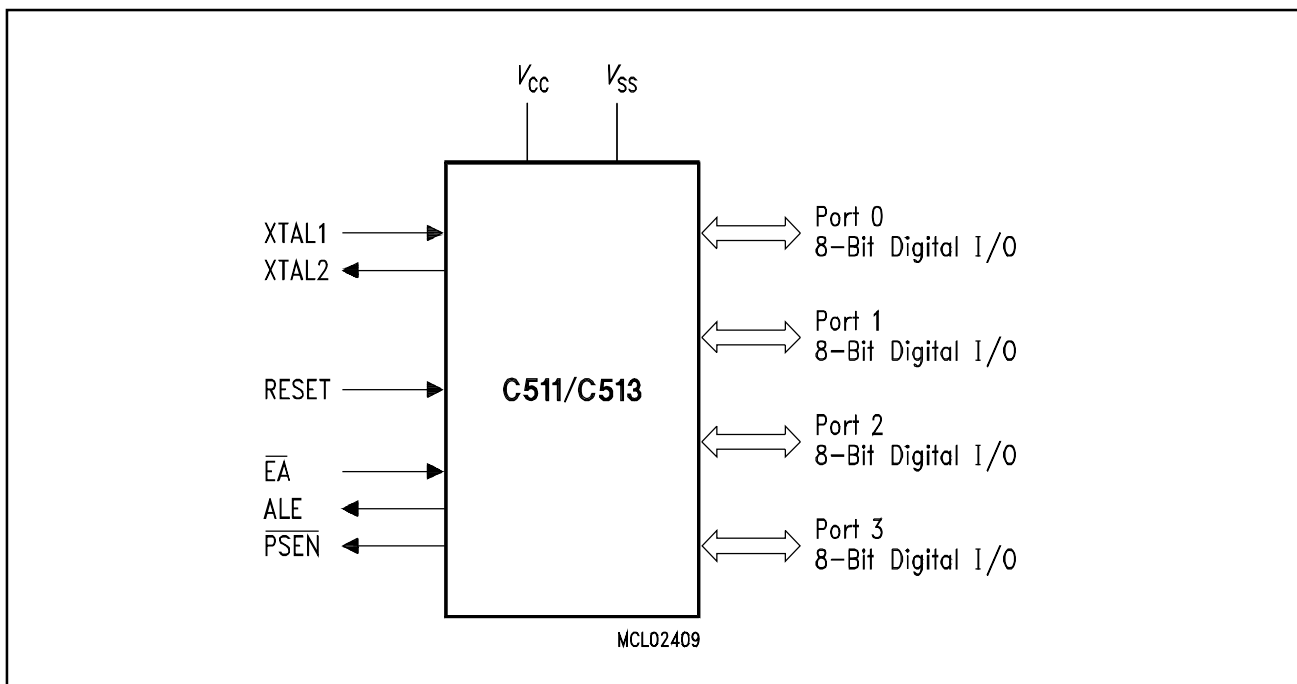
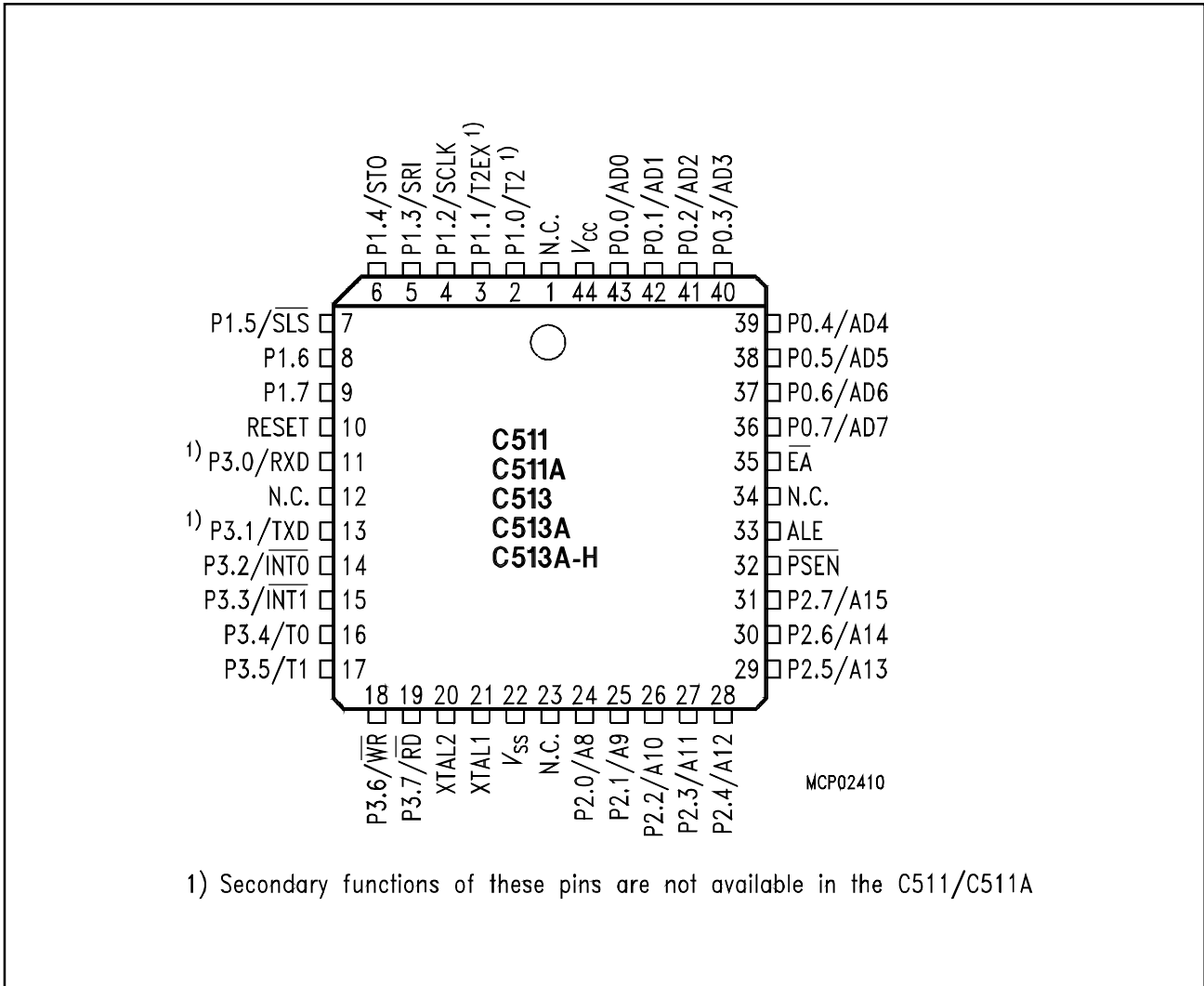

**Figure 1**  
**C511/513 Logic Symbol**

**Table 2**  
**Ordering Information**

Type	Ordering Code	Package	Description (8-Bit CMOS microcontroller)
C511-RN	Q67120-DXXXX	P-LCC-44	with mask-programmable ROM (2.5K), 12 MHz
C511A-RN	Q67120-DXXXX	P-LCC-44	with mask-programmable ROM (4K), 12 MHz
C513-1RN	Q67120-DXXXX	P-LCC-44	with mask-programmable ROM (8K), 12 MHz
C513A-RN	Q67120-DXXXX	P-LCC-44	with mask-programmable ROM (12K), 12 MHz
	Q67120-DXXXX	P-LCC-44	with mask-programmable ROM (12K), 12 MHz, ext. temp. – 40 °C to 85 °C
C513A-2RN	Q67120-DXXXX	P-LCC-44	with mask-programmable ROM (16K), 12 MHz
	Q67120-DXXXX	P-LCC-44	with mask-programmable ROM (16K), 12 MHz, ext. temp. – 40 °C to 85 °C
C513A-2RM	Q67120-DXXXX	P-MQFP-44	with mask-programmable ROM (16K), 12 MHz
	Q67120-DXXXX	P-MQFP-44	with mask-programmable ROM (16K), 12 MHz, ext. temp. – 40 °C to 85 °C
C513A-LN	Q67120-C1017	P-LCC-44	for external memory (12 MHz)
	Q67120-C1035	P-LCC-44	for external memory (12 MHz), ext. temp. – 40 °C to 85 °C
C513A-LM	Q67120-C1026	P-MQFP-44	for external memory (12 MHz)
	Q67120-C1036	P-MQFP-44	for external memory (12 MHz), ext. temp. – 40 °C to 85 °C
C513A-HN	Q67120-C0989	P-LCC-44	with reprogrammable EEPROM (12K), 12 MHz, ext. temp. – 40 °C to 85 °C

**Note :** The ordering number of the ROM types (DXXXX extension) is defined after program release (verification) of the customer.



**Figure 2**  
**P-LCC-44 Package Pin Configuration (Top View)**

If the C513A-H is used in programming mode, the pin configuration is different to **figure 2** and **3** (see **figure 5**).

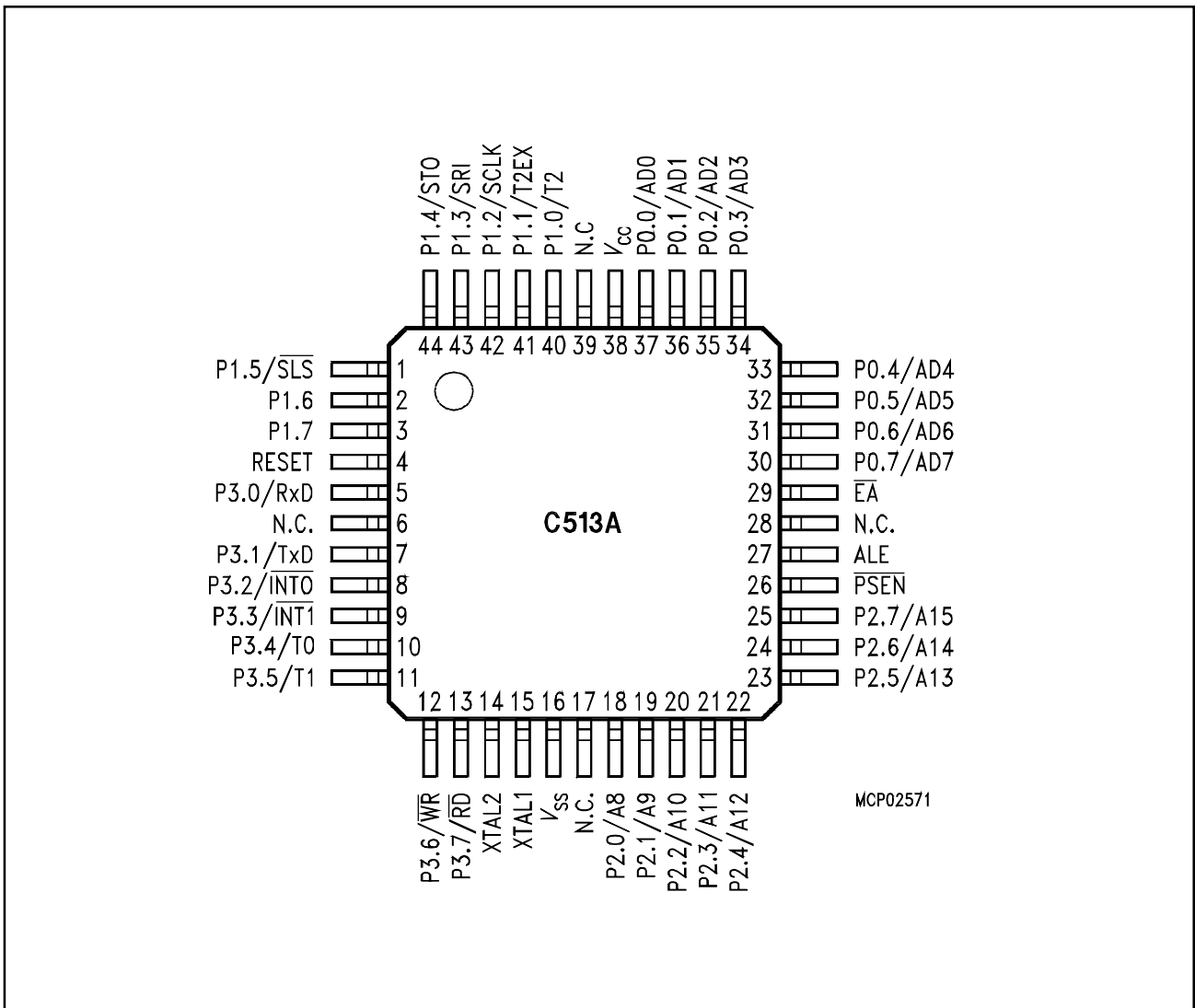

**Figure 3**  
**P-MQFP-44 Package Pin Configuration of the C513A (Top View)**

**Table 3**  
**Pin Definitions and Functions**

Symbol	Pin Number		I/O*)	Function																		
	P-LCC-44	P-MQFP-44																				
P1.7-P1.0	9-2	3-1, 44-40	I/O	<p><b>Port 1</b> is a bidirectional I/O port with internal pull-up resistors. Port 1 pins that have 1s written to them are pulled high by the internal pullup resistors, and in that state can be used as inputs. As inputs, port 1 pins being externally pulled low will source current (<math>I_{IL}</math>, in the DC characteristics) because of the internal pullup resistors. Port 1 also contains the timer 2 and SSC pins as secondary function. In general the output latch corresponding to a secondary function must be programmed to a one (1) for that function to operate. For the outputs of the SSC (SCLK, STO) special circuitry is implemented, providing true push-pull capability. The STO output in addition will have true tristate capability. When used for SSC inputs, the pull-up resistors will be switched off and the inputs will float (high ohmic inputs).</p> <p>The alternate functions are assigned to port 1, as follows:</p> <table border="0"> <tr> <td>P1.0</td> <td>T2</td> <td>Input to counter 2 <sup>1)</sup></td> </tr> <tr> <td>P1.1</td> <td>T2EX</td> <td>Capture -Reload trigger of timer 2 <sup>1)</sup> Up-Down count</td> </tr> <tr> <td>P1.2</td> <td>SCLK</td> <td>SSC Master Clock Output SSC Slave Clock Input</td> </tr> <tr> <td>P1.3</td> <td>SRI</td> <td>SSC Receive Input</td> </tr> <tr> <td>P1.4</td> <td>STO</td> <td>SSC Transmit Output</td> </tr> <tr> <td>P1.5</td> <td><math>\overline{SLS}</math></td> <td>Slave Select Input</td> </tr> </table> <p><sup>1)</sup> not available in the C511/511A</p>	P1.0	T2	Input to counter 2 <sup>1)</sup>	P1.1	T2EX	Capture -Reload trigger of timer 2 <sup>1)</sup> Up-Down count	P1.2	SCLK	SSC Master Clock Output SSC Slave Clock Input	P1.3	SRI	SSC Receive Input	P1.4	STO	SSC Transmit Output	P1.5	$\overline{SLS}$	Slave Select Input
P1.0	T2	Input to counter 2 <sup>1)</sup>																				
P1.1	T2EX	Capture -Reload trigger of timer 2 <sup>1)</sup> Up-Down count																				
P1.2	SCLK	SSC Master Clock Output SSC Slave Clock Input																				
P1.3	SRI	SSC Receive Input																				
P1.4	STO	SSC Transmit Output																				
P1.5	$\overline{SLS}$	Slave Select Input																				
	2	40																				
	3	41																				
	4	42																				
	5	43																				
	6	44																				
	7	1																				

\*) I = Input  
O = Output



**Table 3**  
**Pin Definitions and Functions (cont'd)**

Symbol	Pin Number		I/O*	Function
	P-LCC-44	P-MQFP-44		
P3.0-P3.7	11, 13-19	5, 7-13	I/O	<p><b>Port 3</b> is a bidirectional I/O port with internal pull-up resistors. Port 3 pins that have 1s written to them are pulled high by the internal pullup resistors, and in that state can be used as inputs. As inputs, port 3 pins being externally pulled low will source current (<math>I_{IL}</math>, in the DC characteristics) because of the internal pullup resistors. Port 3 also contains the interrupt, timer, serial port and external memory strobe pins that are used by various options. The output latch corresponding to a secondary function must be programmed to a one (1) for that function to operate.</p> <p>The secondary functions are assigned to the pins of port 3 as follows:</p>
	11	5	P3.0	RXD Receiver data input (asynchronous) or data input/output (synchronous) of serial interface (USART) <sup>1)</sup>
	13	7	P3.1	TXD Transmitter data output (USART) <sup>1)</sup> (asynchronous) or clock output (synchronous) of serial interface
	14	8	P3.2	$\overline{INT0}$ Interrupt 0 input / timer 0 gate control
	15	9	P3.3	$\overline{INT1}$ Interrupt 1 input / timer 1 gate control
	16	10	P3.4	T0 Counter 0 input
	17	11	P3.5	T1 Counter 1 input
	18	12	P3.6	$\overline{WR}$ Write control signal : latches the data byte from port 0 into the external data memory
	19	13	P3.7	$\overline{RD}$ Read control signal : enables the external data memory to port 0
				<sup>1)</sup> not available in the C511/511A
XTAL2	20	14	–	<p><b>XTAL2</b> Output of the inverting oscillator amplifier.</p>

\*) I = Input  
O = Output

**Table 3**  
**Pin Definitions and Functions** (cont'd)

Symbol	Pin Number		I/O*)	Function
	P-LCC-44	P-MQFP-44		
XTAL1	21	15	–	<p><b>XTAL1</b></p> <p>Input to the inverting oscillator amplifier and input to the internal clock generator circuits.</p> <p>To drive the device from an external clock source, XTAL1 should be driven, while XTAL2 is left unconnected. There are no requirements on the duty cycle of the external clock signal, since the input to the internal clocking circuitry is divided down by a divide-by-two flip-flop. Minimum and maximum high and low times as well as rise/fall times specified in the AC characteristics must be observed.</p>
P2.0-P2.7	24-31	18-25	I/O	<p><b>Port 2</b></p> <p>is a bidirectional I/O port with internal pullup resistors. Port 2 pins that have 1s written to them are pulled high by the internal pullup resistors, and in that state can be used as inputs. As inputs, port 2 pins being externally pulled low will source current (<math>I_{IL}</math>, in the DC characteristics) because of the internal pullup resistors. Port 2 emits the high-order address byte during fetches from external program memory and during accesses to external data memory that use 16-bit addresses (MOVX @DPTR). In this application it uses strong internal pullup resistors when issuing 1s. During accesses to external data memory that use 8-bit addresses (MOVX @Ri), port 2 issues the contents of the P2 special function register.</p>
$\overline{\text{PSEN}}$	32	26	O	<p>The <b>Program Store Enable</b> output is a control signal that enables the external program memory to the bus during external fetch operations. It is activated every six oscillator periods except during external data memory accesses. Remains high during internal program execution.</p>
RESET	10	4	I	<p><b>RESET</b></p> <p>A high level on this pin for two machine cycles while the oscillator is running resets the device. An internal resistor to <math>V_{SS}</math> permits power-on reset using only an external capacitor to <math>V_{CC}</math>.</p>

\*) I = Input  
O = Output

**Table 3**  
**Pin Definitions and Functions** (cont'd)

Symbol	Pin Number		I/O*)	Function										
	P-LCC-44	P-MQFP-44												
ALE	33	27	O	<p>The <b>Address Latch Enable</b> output is used for latching the low-byte of the address into external memory during normal operation. It is activated every six oscillator periods except during an external data memory access.</p> <p>If no external memory is used, the ALE signal generation can be inhibited, reducing system RFI, by clearing register bit EALE in the SYSCON register.</p>										
$\overline{EA}$	35	29	I	<p><b>External Access Enable</b></p> <p>When held at high level, instructions are fetched from the internal ROM when the PC is less than the size of the internal ROM :</p> <table style="margin-left: 20px;"> <tr> <td>C511</td> <td>0A00<sub>H</sub></td> </tr> <tr> <td>C511A</td> <td>1000<sub>H</sub></td> </tr> <tr> <td>C513</td> <td>2000<sub>H</sub></td> </tr> <tr> <td>C513A/A-H</td> <td>3000<sub>H</sub></td> </tr> <tr> <td>C513A-2R</td> <td>4000<sub>H</sub></td> </tr> </table> <p>When held at low level, the microcontroller fetches all instructions from external program memory.</p>	C511	0A00 <sub>H</sub>	C511A	1000 <sub>H</sub>	C513	2000 <sub>H</sub>	C513A/A-H	3000 <sub>H</sub>	C513A-2R	4000 <sub>H</sub>
C511	0A00 <sub>H</sub>													
C511A	1000 <sub>H</sub>													
C513	2000 <sub>H</sub>													
C513A/A-H	3000 <sub>H</sub>													
C513A-2R	4000 <sub>H</sub>													
P0.0-P0.7	43-36	37-30	I/O	<p><b>Port 0</b></p> <p>is an 8-bit open-drain bidirectional I/O port. Port 0 pins that have 1s written to them float, and in that state can be used as high-impedance inputs. Port 0 is also the multiplexed low-order address and data bus during accesses to external program or data memory. In this application it uses strong internal pullup transistors when issuing 1s. External pullup resistors are required during program verification.</p>										
$V_{SS}$	22	16	–	<b>Circuit ground potential</b>										
$V_{CC}$	44	38	–	<b>Power Supply terminal</b> for all operating modes										
N.C.	1, 12, 23, 34	6, 17, 28, 39	–	<b>No connection</b> , do not connect externally										

\*) I = Input  
O = Output

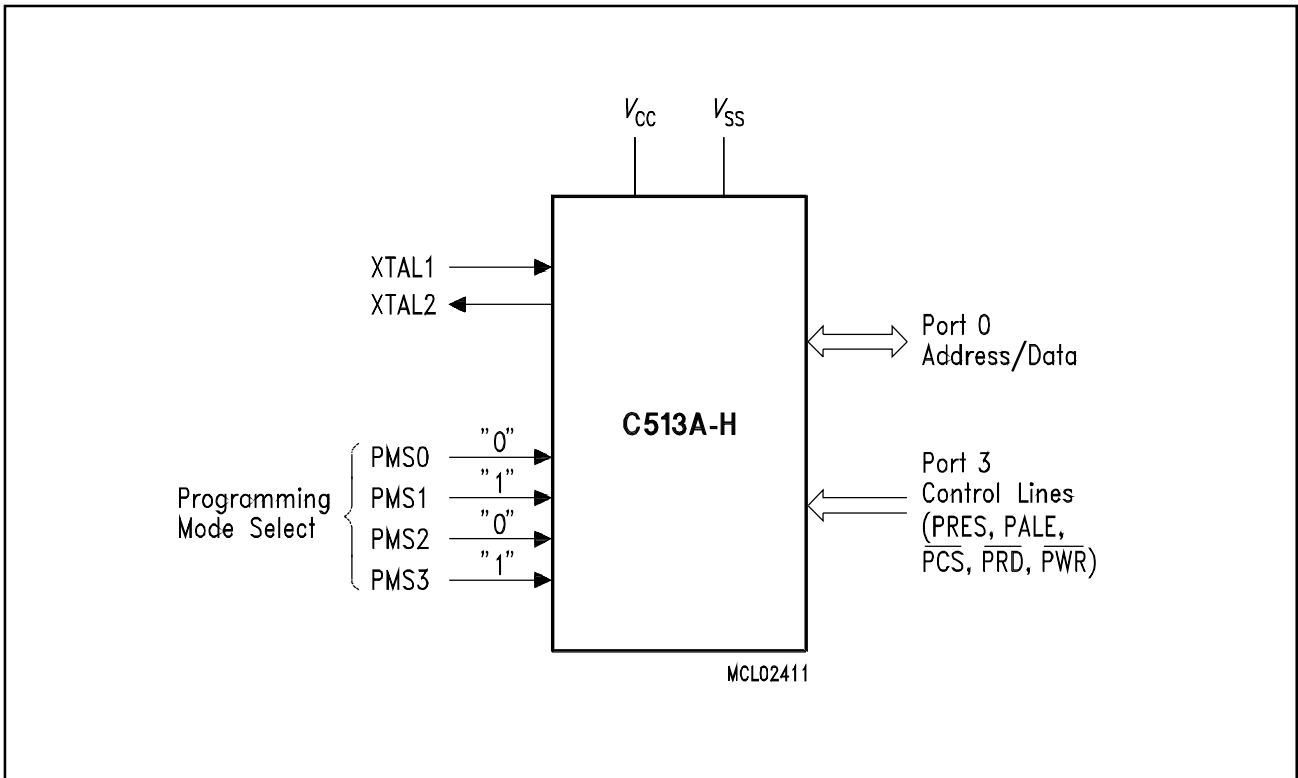

**Figure 4**  
C513A-H Logic Symbol in Programming Mode

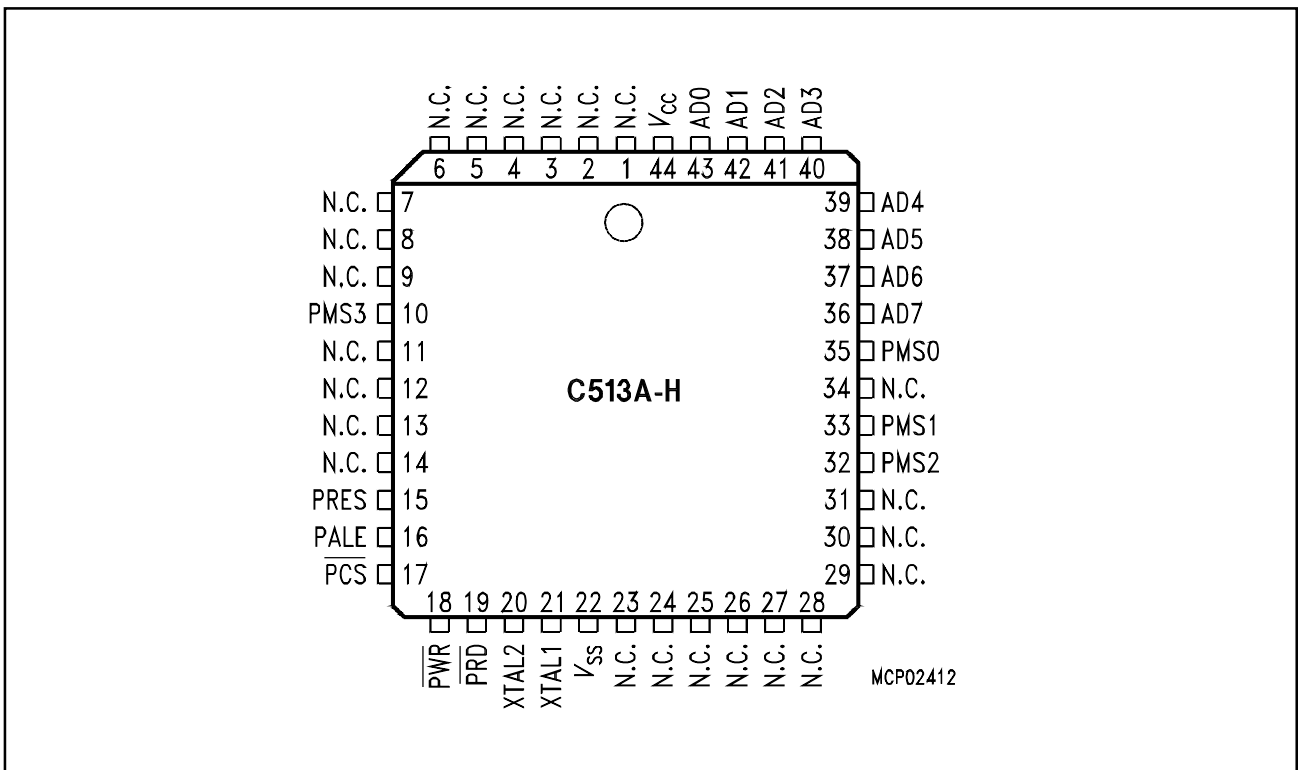

**Figure 5**  
C513A-H Pin Configuration in Programming Mode (P-LCC-44)

**Table 4**  
**Pin Definitions and Functions in Programming Mode (C513A-H only)**

Symbol	Pin Number	I/O*)	Function
	P-LCC-44		
PRES	15	I	<b>Programming Interface Reset</b> A high level on this input resets the programming interface and its registers to their initial state.
AD0 - AD7	43 - 36	I/O	<b>Bidirectional Address/Data Bus</b> AD0-7 is used to transfer data to and from the registers of the programming interface and to read the data of the memory field during EEPROM verification.
PALE	16	I	<b>Programming Address Latch Enable</b> This input is used to latch address information at AD0-7. The trailing edge of PALE is used to latch the register addresses. Each read or write access in programming mode must be initiated by a PALE high pulse.
$\overline{\text{PRD}}$	18	I	<b>Programming Read Control</b> A low level at this pin (and $\overline{\text{PCS}}=\text{low}$ ) enables the AD0-7 buffers for reading of the data or control registers of the programming interface.
$\overline{\text{PWR}}$	19	I	<b>Programming Write Control</b> A low level at this pin (and $\overline{\text{PCS}}=\text{low}$ ) causes the data at AD0-7 to be written into the data or control registers of the programming interface.
$\overline{\text{PCS}}$	17	I	<b>Programming Chip Select</b> A low level at this pin enables the access to the registers of the programming interface. If $\overline{\text{PCS}}$ is active, either $\overline{\text{PRD}}$ or $\overline{\text{PWR}}$ control whether data is read or written into the registers. $\overline{\text{PCS}}$ should be always deactivated between subsequent accesses to the programming interface.
XTAL2	20	–	<b>XTAL2</b> Output of the inverting oscillator amplifier.
XTAL1	21	–	<b>XTAL1</b> Input to the inverting oscillator amplifier and input to the internal clock generator circuits. To drive the device from an external clock source, XTAL1 should be driven, while XTAL2 is left unconnected. During the device programming a clock must be always supplied.

\*) I = Input  
 O = Output

**Table 4**  
**Pin Definitions and Functions in Programming Mode (C513A-H only) (cont'd)**

Symbol	Pin Number	I/O*	Function															
	P-LCC-44																	
PMS0 PMS1 PMS2 PMS3	35 33 32 10	I	<p><b>Programming Mode Select</b>            PMS0-3 are used to put the C513A-H into the programming mode. In normal mode the programming mode select pins have the meaning as shown in the table below. PMS0-3 must be set to the logic level as described in the table below.</p> <table border="1" style="margin-left: auto; margin-right: auto;"> <thead> <tr> <th>Normal Mode Pin Names</th> <th>Progr. Mode Pin Names</th> <th>Required Logic Level</th> </tr> </thead> <tbody> <tr> <td><math>\overline{EA}</math></td> <td>PMS0</td> <td>0</td> </tr> <tr> <td>ALE</td> <td>PMS1</td> <td>1</td> </tr> <tr> <td><math>\overline{PSEN}</math></td> <td>PMS2</td> <td>0</td> </tr> <tr> <td>RESET</td> <td>PMS3</td> <td>1</td> </tr> </tbody> </table>	Normal Mode Pin Names	Progr. Mode Pin Names	Required Logic Level	$\overline{EA}$	PMS0	0	ALE	PMS1	1	$\overline{PSEN}$	PMS2	0	RESET	PMS3	1
Normal Mode Pin Names	Progr. Mode Pin Names	Required Logic Level																
$\overline{EA}$	PMS0	0																
ALE	PMS1	1																
$\overline{PSEN}$	PMS2	0																
RESET	PMS3	1																
$V_{SS}$	22	–	<b>Circuit ground potential</b>															
$V_{CC}$	44	–	<b>Power supply terminal</b> for all operating modes															
N.C.	1-9, 11-14, 23-31, 34	–	<p><b>No connection</b>            These pins must not be connected.</p>															

\*) I = Input  
 O = Output

**Functional Description**

The C511/C513 microcontrollers are fully compatible to the standard 8051/80C52 and C500 microcontroller family. While maintaining all architectural and operational characteristics of the 80C52/C500 the C511/C513 incorporates enhancements such as additional internal XRAM and a second (synchronous) serial interface unit.

Figure 6 shows a block diagram of the C511/C513 microcontroller family.

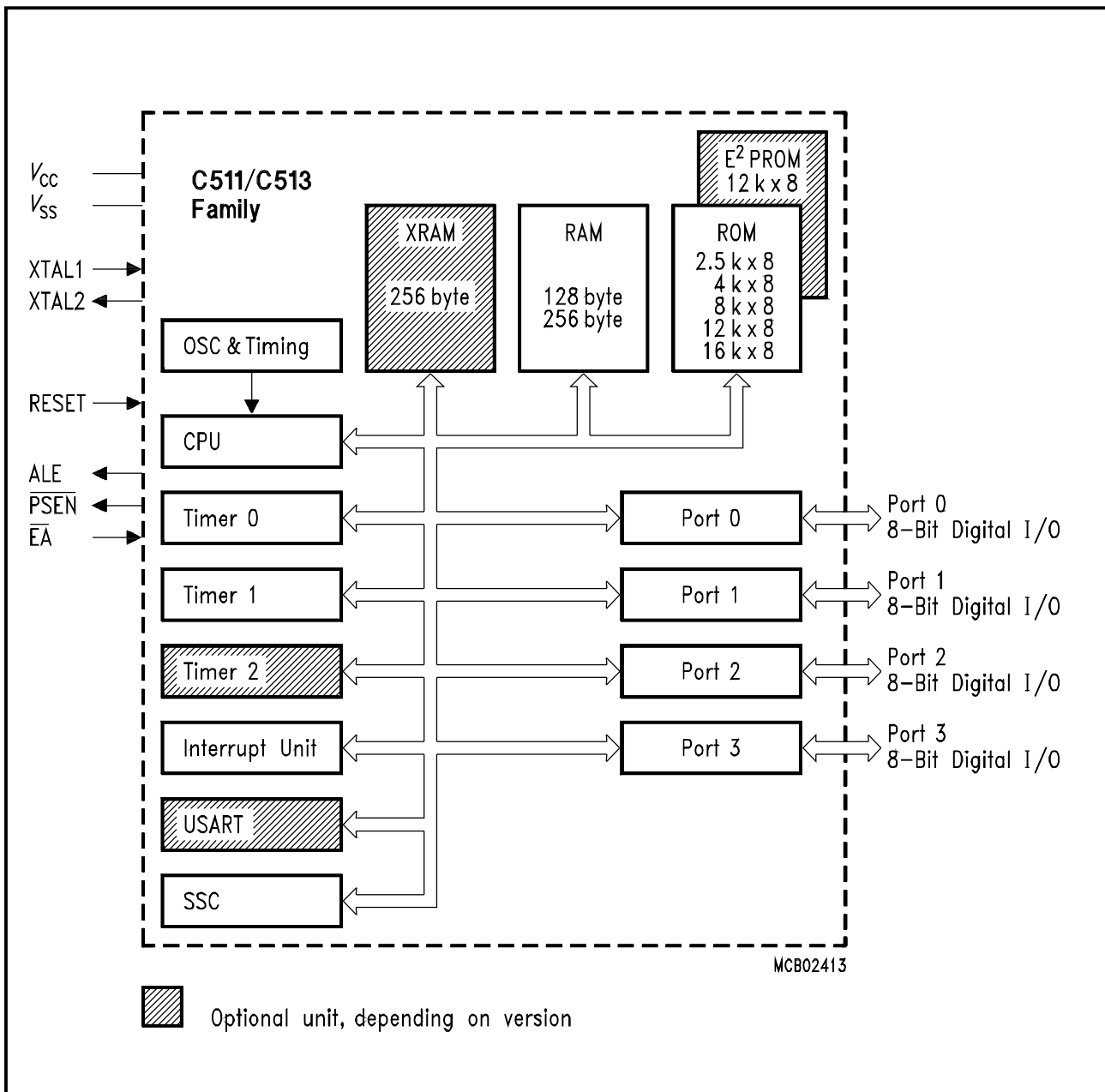

**Figure 6**  
**Block Diagram of the C511/C513 Units**

## CPU

The C511/C513 are efficient both as a controller and as an arithmetic processor. It has extensive facilities for binary and BCD arithmetic and for bit-handling capabilities. Efficient use of program memory results from an instruction set consisting of 44 % one-byte, 41 % two-byte, and 15 % three-byte instructions. With a 12 MHz crystal, 58 % of the instructions execute in 1  $\mu$ s.

### Special Function Register PSW (Address D0<sub>H</sub>)

Reset Value : 00<sub>H</sub>

	MSB						LSB		
Bit No.	7	6	5	4	3	2	1	0	
D0 <sub>H</sub>	CY	AC	F0	RS1	RS0	OV	F1	P	PSW

Bit	Function
CY	Carry Flag
AC	Auxiliary Carry Flag (for BCD operations)
F0	General Purpose Flag
RS1 RS0	Register Bank select control bits
0 0	Bank 0 selected, data address 00 <sub>H</sub> -07 <sub>H</sub>
0 1	Bank 1 selected, data address 08 <sub>H</sub> -0F <sub>H</sub>
1 0	Bank 2 selected, data address 10 <sub>H</sub> -17 <sub>H</sub>
1 1	Bank 3 selected, data address 18 <sub>H</sub> -1F <sub>H</sub>
OV	Overflow Flag
F1	General Purpose Flag
P	Parity Flag Set/cleared by hardware each instruction cycle to indicate an odd/even number of "one" bits in the accumulator, i.e. even parity.



### Special Function Registers

All registers except the program counter and the four general purpose register banks reside in the special function register area.

The 34 special function registers (SFR) include pointers and registers that provide an interface between the CPU and the other on-chip peripherals. There are also 128 directly addressable bits within the SFR area.

All SFRs are listed in **table 5** and **table 6**. In **table 5** they are organized in groups which refer to the functional blocks of the C511/C513. **Table 6** illustrates the contents of the SFRs, e.g. the bits of the SFRs, in numeric order of their addresses.

**Table 5**  
**SFRs - Functional Blocks**

Block	Symbol	Name	Address	Contents after Reset
CPU	ACC	Accumulator	<b>E0H</b> <sup>1)</sup>	<b>00H</b>
	B	B-Register	<b>F0H</b> <sup>1)</sup>	<b>00H</b>
	DPH	Data Pointer, High Byte	83H	00H
	DPL	Data Pointer, Low Byte	82H	00H
	PSW	Program Status Word	<b>D0H</b> <sup>1)</sup>	<b>00H</b>
	SP	Stack Pointer	81H	07H
	SYSCON	System Control Reg. C511/C511A/C513 C513A/C513A-H	B1H B1H	101X0XXX <sub>B</sub> <sup>3)</sup> 101X0XX0 <sub>B</sub> <sup>3)</sup>
Interrupt System	IE	Interrupt Enable Register	<b>A8H</b> <sup>1)</sup>	<b>00H</b>
	IP	Interrupt Priority Register	<b>B8H</b> <sup>1)</sup>	<b>X0000000<sub>B</sub></b> <sup>3)</sup>
Ports	P0	Port 0	<b>80H</b> <sup>1)</sup>	<b>FFH</b>
	P1	Port 1	<b>90H</b> <sup>1)</sup>	<b>FFH</b>
	P2	Port 2	<b>A0H</b> <sup>1)</sup>	<b>FFH</b>
	P3	Port 3	<b>B0H</b> <sup>1)</sup>	<b>FFH</b>
SSC	SSCCON	SSC Control Register	<b>E8H</b> <sup>1)</sup>	<b>07H</b>
	STB	SSC Transmit Buffer	E9H	XX <sub>H</sub> <sup>3)</sup>
	SRB	SSC Receive Register	EAH	XX <sub>H</sub> <sup>3)</sup>
	SCF	SSC Flag Register	<b>F8H</b> <sup>1)</sup>	<b>XXXXXX00<sub>B</sub></b> <sup>3)</sup>
	SCIEN	SSC Interrupt Enable Register	F9H	XXXXXX00 <sub>B</sub> <sup>3)</sup>
	SSCMOD	SSC Mode Test Register	EBH	00H
USART	PCON <sup>2)</sup>	Power Control Register	87H	0XXX0000 <sub>B</sub> <sup>3)</sup>
	SBUF	Serial Channel Buffer Register	99H	XX <sub>H</sub> <sup>3)</sup>
	SCON	Serial Channel 1 Control Register	<b>98H</b> <sup>1)</sup>	00H
Timer 0 / Timer 1	TCON	Timer Control Register	<b>88H</b> <sup>1)</sup>	<b>00H</b>
	TMOD	Timer Mode Register	89H	00H
	TL0	Timer 0, Low Byte	8AH	00H
	TL1	Timer 1, Low Byte	8BH	00H
	TH0	Timer 0, High Byte	8CH	00H
	TH1	Timer 1, High Byte	8DH	00H
Timer 2	T2CON	Timer 2 Control Register	<b>C8H</b> <sup>1)</sup>	00H
	T2MOD	Timer 2 Mode Register	C9H	XXXXXXXX0 <sub>B</sub> <sup>3)</sup>
	RC2L	Timer 2 Reload/Capture Register, Low Byte	CAH	00H
	RC2H	Timer 2 Reload/Capture Register, High Byte	CBH	00H
	TL2	Timer 2 Low Byte	CCH	00H
	TH2	Timer 2 High Byte	CDH	00H
Power Save Mode	PCON <sup>2)</sup>	Power Control Register	87H	0XXX0000 <sub>B</sub> <sup>3)</sup>

<sup>1)</sup> Bit-addressable special function registers

<sup>2)</sup> This special function register is listed repeatedly since some bits of it also belong to other functional blocks.

<sup>3)</sup> X means that the value is indeterminate and the location is reserved

**Table 6**  
**Contents of the SFRs, SFRs in Numeric Order of their Addresses**

Addr	Register	Content after Reset <sup>1)</sup>	Bit 7	Bit 6	Bit 5	Bit 4	Bit 3	Bit 2	Bit 1	Bit 0
80 <sub>H</sub>	P0	FF <sub>H</sub>	.7	.6	.5	.4	.3	.2	.1	.0
81 <sub>H</sub>	SP	07 <sub>H</sub>	.7	.6	.5	.4	.3	.2	.1	.0
82 <sub>H</sub>	DPL	00 <sub>H</sub>	.7	.6	.5	.4	.3	.2	.1	.0
83 <sub>H</sub>	DPH	00 <sub>H</sub>	.7	.6	.5	.4	.3	.2	.1	.0
87 <sub>H</sub>	PCON	0XXX-0000 <sub>B</sub>	SMOD	–	–	–	GF1	GF0	PDE	IDLE
88 <sub>H</sub>	TCON	00 <sub>H</sub>	TF1	TR1	TF0	TR0	IE1	IT1	IE0	IT0
89 <sub>H</sub>	TMOD	00 <sub>H</sub>	GATE	C/ $\bar{T}$	M1	M0	GATE	C/ $\bar{T}$	M1	M0
8A <sub>H</sub>	TL0	00 <sub>H</sub>	.7	.6	.5	.4	.3	.2	.1	.0
8B <sub>H</sub>	TL1	00 <sub>H</sub>	.7	.6	.5	.4	.3	.2	.1	.0
8C <sub>H</sub>	TH0	00 <sub>H</sub>	.7	.6	.5	.4	.3	.2	.1	.0
8D <sub>H</sub>	TH1	00 <sub>H</sub>	.7	.6	.5	.4	.3	.2	.1	.0
90 <sub>H</sub>	P1	FF <sub>H</sub>	–	–	SLS	STO	SRI	SCLK	T2EX	T2
98 <sub>H</sub>	SCON	00 <sub>H</sub>	SM0	SM1	SM2	REN	TB8	RB8	TI	RI
99 <sub>H</sub>	SBUF	XX <sub>H</sub>	.7	.6	.5	.4	.3	.2	.1	.0
A0 <sub>H</sub>	P2	FF <sub>H</sub>	.7	.6	.5	.4	.3	.2	.1	.0
A8 <sub>H</sub>	IE	00 <sub>H</sub>	EAL	ESSC	ET2	ES0	ET1	EX1	ET0	EX0
B0 <sub>H</sub>	P3	FF <sub>H</sub>	RD	WR	T1	T0	INT1	INT0	TxD0	RxD0
B1 <sub>H</sub>	SYSCON	<sup>2)</sup>	1	0	EAL	–	0	–	–	XMAP <sup>2)</sup>
B8 <sub>H</sub>	IP	X000-0000 <sub>B</sub>	–	PSSC	PT2	PS	PT1	PX1	PT0	PX0
C8 <sub>H</sub>	T2CON	00 <sub>H</sub>	TF2	EXF2	RCLK	TCLK	EXEN2	TR2	C/ $\bar{T}2$	CP/ RL2
C9 <sub>H</sub>	T2MOD	XXXX-XXX0 <sub>B</sub>	–	–	–	–	–	–	–	DCEN
CA <sub>H</sub>	RC2L	00 <sub>H</sub>	.7	.6	.5	.4	.3	.2	.1	.0
CB <sub>H</sub>	RC2H	00 <sub>H</sub>	.7	.6	.5	.4	.3	.2	.1	.0
CC <sub>H</sub>	TL2	00 <sub>H</sub>	.7	.6	.5	.4	.3	.2	.1	.0
CD <sub>H</sub>	TH2	00 <sub>H</sub>	.7	.6	.5	.4	.3	.2	.1	.0
D0 <sub>H</sub>	PSW	00 <sub>H</sub>	CY	AC	F0	RS1	RS0	OV	F1	P
E0 <sub>H</sub>	ACC	00 <sub>H</sub>	.7	.6	.5	.4	.3	.2	.1	.0
E8 <sub>H</sub>	SSCCON	07 <sub>H</sub>	SCEN	TEN	MSTR	CPOL	CPHA	BRS2	BRS1	BRS0
E9 <sub>H</sub>	STB	XX <sub>H</sub>	.7	.6	.5	.4	.3	.2	.1	.0
EA <sub>H</sub>	SRB	XX <sub>H</sub>	.7	.6	.5	.4	.3	.2	.1	.0
EB <sub>H</sub>	SSCMOD	00 <sub>H</sub> <sup>3)</sup>	0	0	0	0	0	0	0	0
F0 <sub>H</sub>	B	00 <sub>H</sub>	.7	.6	.5	.4	.3	.2	.1	.0

**Table 6**  
**Contents of the SFRs, SFRs in Numeric Order of their Addresses (cont'd)**

Addr	Register	Content after Reset <sup>1)</sup>	Bit 7	Bit 6	Bit 5	Bit 4	Bit 3	Bit 2	Bit 1	Bit 0
F8 <sub>H</sub>	SCF	XXXX- XX00 <sub>B</sub>	–	–	–	–	–	–	WCOL	TC
F9 <sub>H</sub>	SCIEN	XXXX- XX00 <sub>B</sub>	–	–	–	–	–	–	WCEN	TCEN

- <sup>1)</sup> X means that the value is indeterminate and the location is reserved.
- <sup>2)</sup> The availability of the XMAP bit and the reset value of SYSCON depends on the specific microcontroller :  
 C511/C511A/C513 : 101X0XXX<sub>B</sub> - bit XMAP is not available  
 C513A/C513A-H : 101X0XX0<sub>B</sub> - bit XMAP is available
- <sup>3)</sup> This register is only used for test purposes and must not be written. Otherwise unpredictable results may occur.  
 Shaded registers are bit-addressable special function registers.

## Timer/ Counter 0 and 1

Timer/Counter 0 and 1 can be used in four operating modes as listed in **table 7**:

**Table 7**  
**Timer/Counter 0 and 1 operating modes**

Mode	Description	TMOD				Input Clock	
		Gate	C/T	M1	M0	internal	external (max)
0	8-bit timer/counter with a divide-by-32 prescaler	X	X	0	0	$f_{osc}/12 \times 32$	$f_{osc}/24 \times 32$
1	16-bit timer/counter	X	X	0	1	$f_{osc}/12$	$f_{osc}/24$
2	8-bit timer/counter with 8-bit auto-reload	X	X	1	0	$f_{osc}/12$	$f_{osc}/24$
3	Timer/counter 0 used as one 8-bit timer/counter and one 8-bit timer Timer 1 stops	X	X	1	1	$f_{osc}/12$	$f_{osc}/24$

In “timer” function ( $C/\bar{T} = '0'$ ) the register is incremented every machine cycle. Therefore the count rate is  $f_{osc}/12$ .

In “counter” function the register is incremented in response to a 1-to-0 transition at its corresponding external input pin (P3.4/T0, P3.5/T1). Since it takes two machine cycles to detect a falling edge the max. count rate is  $f_{osc}/24$ . External inputs  $\overline{INT0}$  and  $\overline{INT1}$  (P3.2, P3.3) can be programmed to function as a gate to facilitate pulse width measurements. **Figure 7** illustrates the input clock logic.

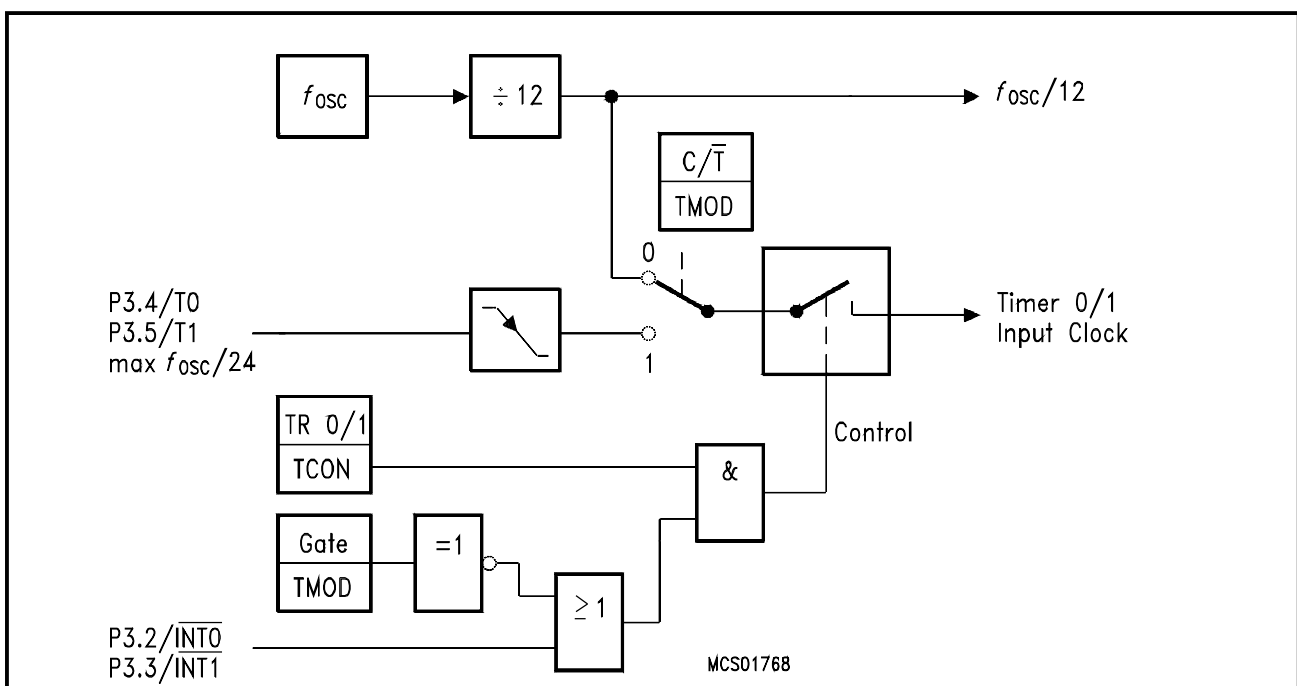

**Figure 7**  
**Timer/Counter 0 and 1 Input Clock Logic**

### Timer / Counter 2 (not available in the C511/C511A)

Timer 2 is a 16-bit Timer/Counter with up/down count feature. It can operate either as timer or as an event counter which is selected by bit  $C/\overline{T2}$  (T2CON.1). It has three operating modes as shown in table 8.

**Table 8**  
**Timer/Counter 2 Operating Modes**

Mode	T2CON			T2MOD	T2CON	P1.1/ T2EX	Remarks	Input Clock	
	R×CLK or T×CLK	CP/ RL2	TR2	DCEN	EXEN			internal	external (P1.0/T2)
16-bit Auto- reload	0	0	1	0	0	X	reload upon overflow	$f_{osc}/12$	max $f_{osc}/24$
	0	0	1	0	1	↓	reload trigger (falling edge)		
	0	0	1	1	X	0	Down counting		
	0	0	1	1	X	1	Up counting		
16-bit Cap- ture	0	1	1	X	0	X	16-bit Timer/Counter (only up-counting)	$f_{osc}/12$	max $f_{osc}/24$
	0	1	1	X	1	↓	capture TH2, TL2 → RC2H, RC2L		
Baud Rate Gene- rator	1	X	1	X	0	X	no overflow interrupt	$f_{osc}/2$	max $f_{osc}/24$
	1	X	1	X	1	↓	request (TF2) extra external interrupt ("Timer 2")		
off	X	X	0	X	X	X	Timer 2 stops	–	–

**Note:** ↓ =  falling edge

**Serial Interface (USART, not available in the C511/C511A)**

The serial port is full duplex and can operate in four modes (one synchronous mode, three asynchronous modes) as illustrated in **table 9**. **Figure 8** illustrates the block diagram of Baudrate generation for the serial interface.

**Table 9**  
**USART Operating Modes**

Mode	SCON		Baudrate	Description
	SM0	SM1		
0	0	0	$f_{osc}/12$	Serial data enters and exits through RxD. TxD outputs the shift clock. 8-bit are transmitted/received (LSB first)
1	0	1	Timer 1/2 overflow rate	8-bit UART 10 bits are transmitted (through TxD) or received (RxD)
2	1	0	$f_{osc}/32$ or $f_{osc}/64$	9-bit UART 11 bits are transmitted (TxD) or received (RxD)
3	1	1	Timer 1/2 overflow rate	9-bit UART Like mode 2 except the variable baud rate

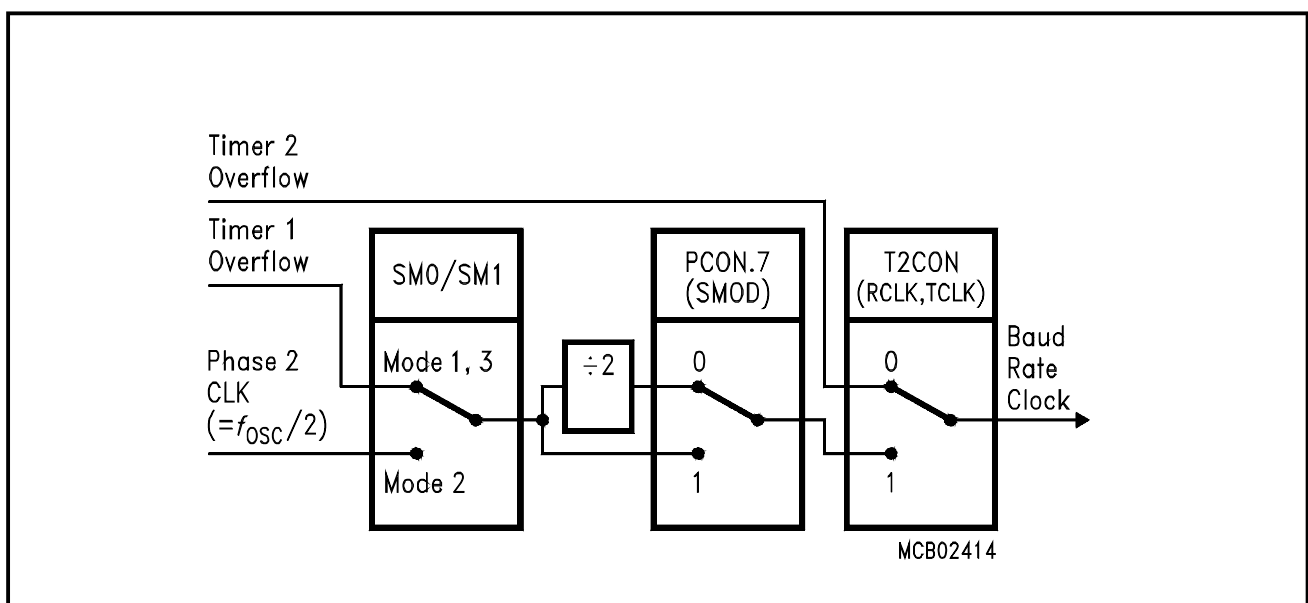

**Figure 8**  
**Block Diagram of Baud Rate Generation for the Serial Interface**

The possible baudrates can be calculated using the formulas given in **table 10**.

**Table 10**  
**Baudrates Selection**

Baud rate derived from	Interface Mode	Baudrate
Oscillator	0 2	$f_{osc}/12$ $(2^{SMOD} \times f_{osc})/64$
Timer 1 (16-bit timer) (8-bit timer with 8-bit autoreload)	1,3 1,3	$(2^{SMOD} \times \text{timer 1 overflow rate})/32$ $(2^{SMOD} \times f_{osc})/(32 \times 12 \times (256-TH1))$
Timer 2	1,3	$f_{osc}/(32 \times (65536-(RC2H, RC2L)))$



**Synchronous Serial Channel (SSC)**

The C511/C513 microcontrollers provide a Synchronous Serial Channel unit, the SSC. This interface is compatible to the popular SPI serial bus interface. It can be used for simple I/O expansion via shift registers, for connection of a variety of peripheral components, such as A/D converters, EEPROMs etc., or for allowing several microcontrollers to be interconnected in a master/slave structure. It supports full-duplex or half-duplex operation and can run in a master or a slave mode. **Figure 9** shows the block diagram of the SSC.

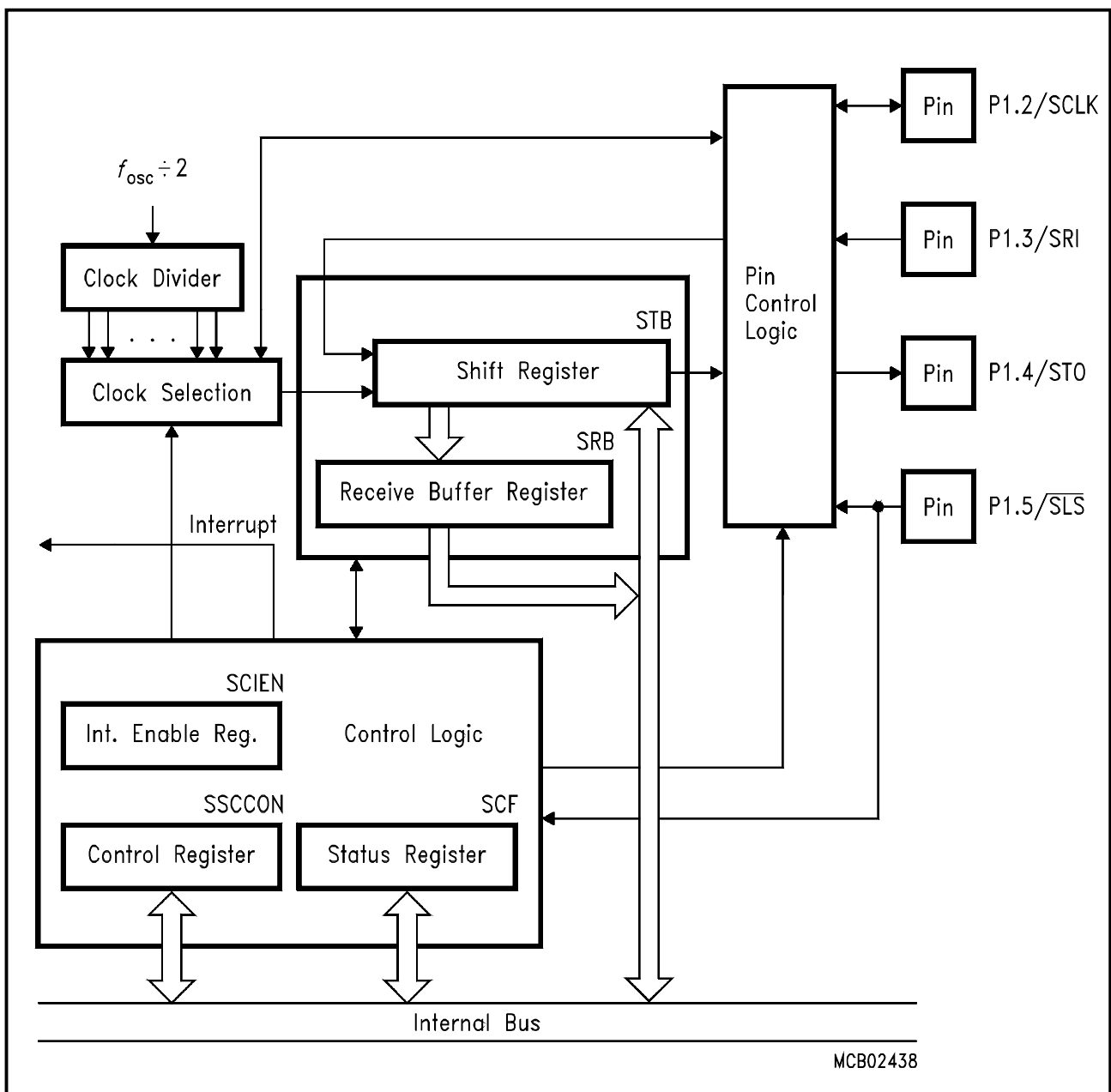

**Figure 9**  
**SSC Blockdiagram**

### Additional On-Chip XRAM (not available in the C511/C511A/C513)

The C513A/C513A-H contain another 256 byte of on-chip RAM additional to the 256 byte internal RAM. This RAM is called XRAM ('eXtended RAM').

The additional on-chip XRAM is logically located in the external data memory range from address FF00<sub>H</sub> to FFFF<sub>H</sub>. The contents of the XRAM are not affected by a reset. After power up the content is undefined, while it remains unchanged during and after reset as long as the power supply is not turned off. The XRAM is controlled by SFR SYSCON as shown in **table 11**.

**Table 11**  
**Control of the XRAM**

SFR SYSCON Bit XMAP	Description
0	Reset value. Access to XRAM is disabled.
1	XRAM enabled. The signals $\overline{RD}$ and $\overline{WR}$ are not activated during MOVX accesses in the XRAM address range.

The XRAM is accessed as external data memory. Therefore, MOVX instruction types must be used for accessing the XRAM. A general overview gives **table 12**.

**Table 12**  
**Accessing the XRAM**

Instruction using	Instruction	Remarks
DPTR (16-bit addr.)	MOVX A @DPTR MOVX @DPTR,A	Normally the use of these instructions would use a physically external memory. However, in the C513A/C513A-H the XRAM is accessed if it is enabled by bit XMAP and the 16-bit address (DPTR) is within the XRAM address range FF00 <sub>H</sub> - FFFF <sub>H</sub> .
R0/R1 (8-bit addr.)	MOVX A, @Ri MOVX @Ri,A	If XRAM is enabled in the C513A/C513A-H, MOVX instructions using Ri will always access the internal XRAM. External data memory cycles will not be generated in this case. If the XRAM is disabled, MOVX instructions using Ri will generate normal external data memory cycles.

**Interrupt System**

The C511/C513 provide 7 interrupt sources with two priority levels. **Figure 10** gives a general overview of the interrupt sources and illustrates the request and control flags.

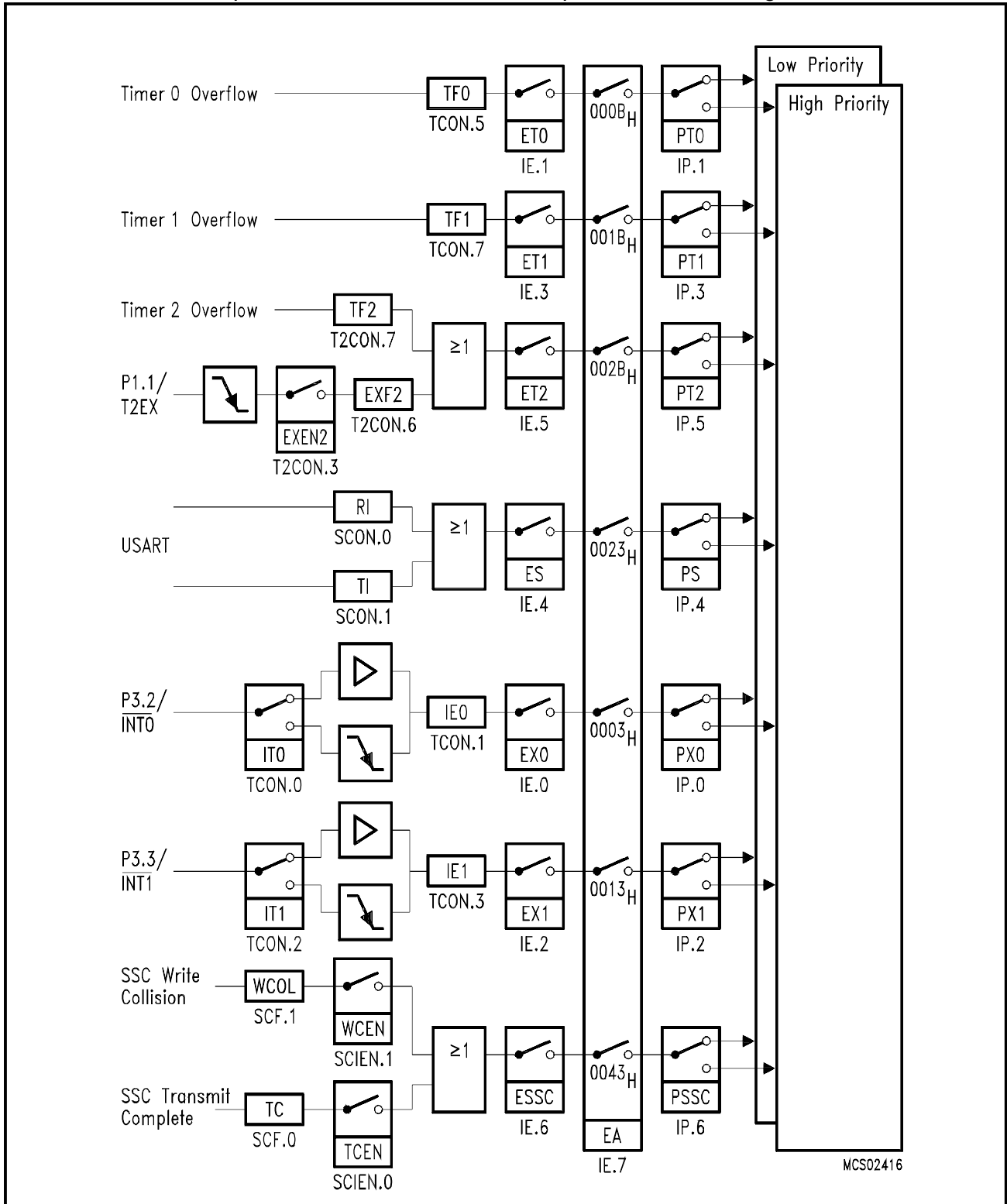

**Figure 10**  
**Interrupt Request Sources**

**Table 13**  
**Interrupt Sources and their Corresponding Interrupt Vectors**

Source (Request Flags)	Vector	Vector Address
IE0	External interrupt 0	0003 <sub>H</sub>
TF0	Timer 0 interrupt	000B <sub>H</sub>
IE1	External interrupt 1	0013 <sub>H</sub>
TF1	Timer 1 interrupt	001B <sub>H</sub>
RI + TI	USART serial port interrupt, (C513/C513A/C513A-H only)	0023 <sub>H</sub>
TF2 + EXF2	Timer 2 interrupt	
SSCI	Synchronous serial channel interrupt (SSC)	002B <sub>H</sub> 0043 <sub>H</sub>

A low-priority interrupt can itself be interrupted by a high-priority interrupt, but not by another low-priority interrupt. A high-priority interrupt cannot be interrupted by any other interrupt source.

If two requests of different priority level are received simultaneously, the request of higher priority is serviced. If requests of the same priority are received simultaneously, an internal polling sequence determines which request is serviced. Thus within each priority level there is a second priority structure determined by the polling sequence as shown in **table 14**.

**Table 14**  
**Priority-within-Level Structure**

Interrupt Source	Priority
External Interrupt 0, IE0	High
Synchronous Serial Channel SSC	
Timer 0 Interrupt, TF0	↓
External Interrupt 1, IE1	
Timer 1 Interrupt, TF1	
Universal Serial Channel, RI or TI	
Timer 2 Interrupt, TF2 or EXF2	Low

## Power Saving Modes

Two power down modes are available, the idle mode and the power down mode. In the idle mode only the CPU will be deactivated while in the power down mode the on-chip oscillator is stopped.

The bits PDE and IDLE select the power down mode or the idle mode, respectively. If the power down mode and the idle mode are set at the same time, power down takes precedence. **Table 15** gives a general overview of the power saving modes.

**Table 15**  
**Entering and leaving the power saving modes**

Mode	Entering Example	Leaving by	Remarks
Idle mode	ORL PCON, #01H	– enabled interrupt – Hardware Reset	CPU is gated off CPU status registers maintain their data. Peripherals are active
Power Down Mode	ORL PCON, #02H	Hardware Reset	Oscillators are stopped. Contents of on-chip RAM and SFR's are maintained (leaving power down mode means redefinition of SFR's contents)

In the power down mode of operation,  $V_{CC}$  can be reduced to minimize power consumption. It must be ensured, however, that  $V_{CC}$  is not reduced before the power down mode is invoked, and that  $V_{CC}$  is restored to its normal operating level, before the power down mode is terminated. The reset signal that terminates the power down mode also restarts the oscillator. The reset should not be activated before  $V_{CC}$  is restored to its normal operating level and must be held active long enough to allow the oscillator to restart and stabilize (similar to power-on reset).

## Absolute Maximum Ratings

Ambient temperature under bias ( $T_A$ ) .....	0 °C to + 70 °C
Storage temperature ( $T_{ST}$ ) .....	- 65 °C to + 150 °C
Voltage on $V_{CC}$ pins with respect to ground ( $V_{SS}$ ) .....	- 0.5 V to 6.5 V
Voltage on any pin with respect to ground ( $V_{SS}$ ).....	- 0.5 V to $V_{CC} + 0.5$ V
Input current on any pin during overload condition.....	- 10 mA to + 10 mA
Absolute sum of all input currents during overload condition .....	100 mA
Power dissipation.....	TBD

### Note:

*Stresses above those listed under “Absolute Maximum Ratings” may cause permanent damage of the device. This is a stress rating only and functional operation of the device at these or any other conditions above those indicated in the operational sections of this specification is not implied. Exposure to absolute maximum rating conditions for longer periods may affect device reliability. During overload conditions ( $V_{IN} > V_{CC}$  or  $V_{IN} < V_{SS}$ ) the Voltage on  $V_{CC}$  pins with respect to ground ( $V_{SS}$ ) must not exceed the values defined by the absolute maximum ratings.*

## DC Characteristics

$V_{CC} = 5\text{ V} + 10\%, -15\%$ ;  $V_{SS} = 0\text{ V}$ ;  $T_A = 0\text{ to } +70\text{ }^\circ\text{C}$

Parameter	Symbol	Limit Values		Unit	Test Condition
		min.	max.		
Input low voltage (except $\overline{EA}$ , RESET)	$V_{IL}$	-0.5	$0.2 V_{CC}$ -0.1	V	-
Input low voltage ( $\overline{EA}$ )	$V_{IL1}$	-0.5	$0.2 V_{CC}$ -0.3	V	-
Input low voltage (RESET)	$V_{IL2}$	-0.5	$0.2 V_{CC}$ +0.1	V	-
Input high voltage (except $\overline{EA}$ , RESET, XTAL1)	$V_{IH}$	$0.2 V_{CC}$ +0.9	$V_{CC} + 0.5$	V	-
Input high voltage to XTAL1	$V_{IH1}$	$0.7 V_{CC}$	$V_{CC} + 0.5$	V	-
Input high voltage to $\overline{EA}$ , RESET	$V_{IH2}$	$0.6 V_{CC}$	$V_{CC} + 0.5$	V	-
Output low voltage Ports 1, 2, 3 (except P1.2, P1.4) Port 0, ALE, $\overline{PSEN}$ P1.2 / P1.4 pull-down transistor resistance	$V_{OL}$ $V_{OL1}$ $R_{DSon}$	-	0.45 0.45 120	V V $\Omega$	$I_{OL} = 1.6\text{ mA}^1)$ $I_{OL} = 3.2\text{ mA}^1)$ $V_{OL} = 0.45\text{ V}$
Output high voltage Ports 1, 2, 3  Port 0 in ext. bus mode, ALE, $\overline{PSEN}$ P1.2 / P1.4 pull-up transistor resistance	$V_{OH}$  $V_{OH1}$  $R_{DSon}$	2.4  2.4  -	- - - 120	V V V $\Omega$	$I_{OH} = -80\text{ }\mu\text{A}$ $I_{OH} = -10\text{ }\mu\text{A}$ $I_{OH} = -800\text{ }\mu\text{A}$ $I_{OH} = -80\text{ }\mu\text{A}$ $V_{OH} = 0.9 V_{CC}$
Logic 0 input current (Ports 1, 2, 3)	$I_{IL}$	-10	-50	$\mu\text{A}$	$V_{IN} = 0.45\text{ V}$
Logical 1-to-0 transition current (Ports 1, 2, 3)	$I_{TL}$	-65	-650	$\mu\text{A}$	$V_{IN} = 2\text{ V}$
Maximum output low current per pin (Ports 0, 1, 2, 3)	$I_{OLM}$	-	5	mA	$V_{OL} \leq 1\text{ V}$
Maximum output low current per port	$I_{PL}$	-	30	mA	-
Input leakage current Port 0 (if $\overline{EA}=0$ ), $\overline{EA}$ , P1.2, P1.3, P1.5 as SSC inputs	$I_{LI}$	-	$\pm 1$	$\mu\text{A}$	$0.45 < V_{IN} < V_{CC}$
Pin capacitance <sup>7)</sup>	$C_{IO}$	-	10	pF	$f_C = 1\text{ MHz}$ , $T_A = 25\text{ }^\circ\text{C}$

## DC Characteristics (cont'd)

$V_{CC} = 5\text{ V} + 10\%, -15\%$ ;  $V_{SS} = 0\text{ V}$ ;  $T_A = 0\text{ to } +70\text{ }^\circ\text{C}$

Parameter	Symbol	Limit Values		Unit	Test Condition
		typ. <sup>8)</sup>	max.		
Power supply current:					
C511/C511A/C513/C513A					
Active mode, 12 MHz <sup>6)</sup>	$I_{CC}$	7	9.5	mA	$V_{CC} = 5\text{ V}$ , <sup>4)</sup>
Idle mode, 12 MHz <sup>6)</sup>	$I_{CC}$	3.5	4.5	mA	$V_{CC} = 5\text{ V}$ , <sup>5)</sup>
Power Down Mode	$I_{PD}$	TBD	50	$\mu\text{A}$	$V_{CC} = 2 \dots 5.5\text{ V}$ , <sup>3)</sup>
C513A-H					
Active mode, 12 MHz <sup>6)</sup>	$I_{CC}$	16	TBD	mA	$V_{CC} = 5\text{ V}$ , <sup>4)</sup>
Idle mode, 12 MHz <sup>6)</sup>	$I_{CC}$	6	TBD	mA	$V_{CC} = 5\text{ V}$ , <sup>5)</sup>
Power Down Mode	$I_{PD}$	TBD	50	$\mu\text{A}$	$V_{CC} = 2 \dots 5.5\text{ V}$ <sup>3)</sup>

### Notes:

- Capacitive loading on ports 0 and 2 may cause spurious noise pulses to be superimposed on the  $V_{OL}$  of ALE and port 3. The noise is due to external bus capacitance discharging into the port 0 and port 2 pins when these pins make 1-to-0 transitions during bus operation. In the worst case (capacitive loading > 100 pF), the noise pulse on ALE line may exceed 0.8 V. In such cases it may be desirable to qualify ALE with a schmitt-trigger, or use an address latch with a schmitt-trigger strobe input.
- Capacitive loading on ports 0 and 2 may cause the  $V_{OH}$  on ALE and  $\overline{\text{PSEN}}$  to momentarily fall below the 0.9  $V_{CC}$  specification when the address lines are stabilizing.
- $I_{PD}$  (Power Down Mode) is measured under following conditions:  
 $\overline{\text{EA}} = \text{Port0} = V_{CC}$ ;  $\text{RESET} = V_{SS}$ ;  $\text{XTAL2} = \text{N.C.}$ ;  $\text{XTAL1} = V_{CC}$ ; all other pins are disconnected.
- $I_{CC}$  (active mode) is measured with:  
 $\text{XTAL1}$  driven with  $t_{CLCH}, t_{CHCL} = 5\text{ ns}$ ,  $V_{IL} = V_{SS} + 0.5\text{ V}$ ,  $V_{IH} = V_{CC} - 0.5\text{ V}$ ;  $\text{XTAL2} = \text{N.C.}$ ;  
 $\overline{\text{EA}} = \text{Port0} = \text{RESET} = V_{CC}$ ; all other pins are disconnected.  $I_{CC}$  would be slightly higher if a crystal oscillator is used (appr. 1 mA).
- $I_{CC}$  (Idle mode) is measured with all output pins disconnected and with all peripherals disabled;  
 $\text{XTAL1}$  driven with  $t_{CLCH}, t_{CHCL} = 5\text{ ns}$ ,  $V_{IL} = V_{SS} + 0.5\text{ V}$ ,  $V_{IH} = V_{CC} - 0.5\text{ V}$ ;  $\text{XTAL2} = \text{N.C.}$ ;  
 $\text{RESET} = \overline{\text{EA}} = V_{SS}$ ;  $\text{Port0} = V_{CC}$ ; all other pins are disconnected;
- $I_{CC\text{Max}}$  at other frequencies is given by:  
C511/C511A/C513/C513A : Active mode: TBD  
Idle mode: TBD  
C513A-H : Active mode: TBD  
Idle mode: TBD  
where  $f_{OSC}$  is the oscillator frequency in MHz.  $I_{CC}$  values are given in mA and measured at  $V_{CC} = 5\text{ V}$ .
- This parameter is periodically sampled and not 100% tested.
- The typical  $I_{CC}$  values are periodically measured at  $T_A = +25\text{ }^\circ\text{C}$  but not 100% tested.



## AC Characteristics (applies to all C511/513 Family Microcontrollers)

$V_{CC} = 5\text{ V} + 10\%, -15\%$ ;  $V_{SS} = 0\text{ V}$   $T_A = 0\text{ °C}$  to  $+70\text{ °C}$

( $C_L$  for port 0, ALE and  $\overline{\text{PSEN}}$  outputs = 100 pF;  $C_L$  for all other outputs = 80 pF)

### Program Memory Characteristics

Parameter	Symbol	Limit Values				Unit
		12 MHz Clock		Variable Clock $1/t_{\text{CLCL}} = 3.5\text{ MHz to }12\text{ MHz}$		
		min.	max.	min.	max.	
ALE pulse width	$t_{\text{LHLL}}$	127	–	$2t_{\text{CLCL}} - 40$	–	ns
Address setup to ALE	$t_{\text{AVLL}}$	43	–	$t_{\text{CLCL}} - 40$	–	ns
Address hold after ALE	$t_{\text{LLAX}}$	60	–	$t_{\text{CLCL}} - 23$	–	ns
ALE low to valid instr in	$t_{\text{LLIV}}$	–	233	–	$4t_{\text{CLCL}} - 100$	ns
ALE to $\overline{\text{PSEN}}$	$t_{\text{LLPL}}$	58	–	$t_{\text{CLCL}} - 25$	–	ns
$\overline{\text{PSEN}}$ pulse width	$t_{\text{PLPH}}$	215	–	$3t_{\text{CLCL}} - 35$	–	ns
$\overline{\text{PSEN}}$ to valid instr in	$t_{\text{PLIV}}$	–	150	–	$3t_{\text{CLCL}} - 100$	ns
Input instruction hold after $\overline{\text{PSEN}}$	$t_{\text{PXIX}}$	0	–	0	–	ns
Input instruction float after $\overline{\text{PSEN}}$	$t_{\text{PXIZ}}^{*)}$	–	63	–	$t_{\text{CLCL}} - 20$	ns
Address valid after $\overline{\text{PSEN}}$	$t_{\text{PXAV}}^{*)}$	75	–	$t_{\text{CLCL}} - 8$	–	ns
Address to valid instr in	$t_{\text{AVIV}}$	–	302	–	$5t_{\text{CLCL}} - 115$	ns
Address float to $\overline{\text{PSEN}}$	$t_{\text{AZPL}}$	0	–	0	–	ns

\*) Interfacing the C511/513 microcontrollers to devices with float times up to 75 ns is permissible. This limited bus contention will not cause any damage to port 0 drivers.

## External Data Memory Characteristics

Parameter	Symbol	Limit Values				Unit
		12 MHz Clock		Variable Clock $1/t_{CLCL} = 3.5 \text{ MHz to } 12 \text{ MHz}$		
		min.	max.	min.	max.	
$\overline{RD}$ pulse width	$t_{RLRH}$	400	–	$6t_{CLCL} - 100$	–	ns
$\overline{WR}$ pulse width	$t_{WLWH}$	400	–	$6t_{CLCL} - 100$	–	ns
Address hold after ALE	$t_{LLAX2}$	132	–	$2t_{CLCL} - 35$	–	ns
$\overline{RD}$ to valid data in	$t_{RLDV}$	–	252	–	$5t_{CLCL} - 165$	ns
Data hold after $\overline{RD}$	$t_{RHDX}$	0	–	0	–	ns
Data float after $\overline{RD}$	$t_{RHDZ}$	–	97	–	$2t_{CLCL} - 70$	ns
ALE to valid data in	$t_{LLDV}$	–	517	–	$8t_{CLCL} - 150$	ns
Address to valid data in	$t_{AVDV}$	–	585	–	$9t_{CLCL} - 165$	ns
ALE to $\overline{WR}$ or $\overline{RD}$	$t_{LLWL}$	200	300	$3t_{CLCL} - 50$	$3t_{CLCL} + 50$	ns
Address valid to $\overline{WR}$ or $\overline{RD}$	$t_{AVWL}$	203	–	$4t_{CLCL} - 130$	–	ns
$\overline{WR}$ or $\overline{RD}$ high to ALE high	$t_{WHLH}$	43	123	$t_{CLCL} - 40$	$t_{CLCL} + 40$	ns
Data valid to $\overline{WR}$ transition	$t_{QVWX}$	33	–	$t_{CLCL} - 50$	–	ns
Data setup before $\overline{WR}$	$t_{QVWH}$	433	–	$7t_{CLCL} - 150$	–	ns
Data hold after $\overline{WR}$	$t_{WHQX}$	33	–	$t_{CLCL} - 50$	–	ns
Address float after $\overline{RD}$	$t_{RLAZ}$	–	0	–	0	ns

## SSC Interface Characteristics

Parameter	Symbol	Limit Values		Unit
		12 MHz Clock		
		min.	max.	
Clock Cycle Time : Master Mode Slave Mode	$t_{SCLK}$	666	–	ns
	$t_{SCLK}$	600	–	ns
Clock high time	$t_{SCH}$	250	–	ns
Clock low time	$t_{SCL}$	250	–	ns
Data output delay	$t_D$	–	100	ns
Data output hold	$t_{HO}$	0	–	ns
Data input setup	$t_S$	100	–	ns
Data input hold	$t_{HI}$	100	–	ns
TC bit set delay	$t_{DTC}$	–	$16 t_{CLCL}$	ns

## External Clock Characteristics

Parameter	Symbol	Limit Values		Unit
		Variable Clock Freq. = 3.5 MHz to 12 MHz		
		min.	max.	
Oscillator period	$t_{CLCL}$	83.3	285	ns
High time	$t_{CHCX}$	20	$t_{CLCL} - t_{CLCX}$	ns
Low time	$t_{CLCX}$	20	$t_{CLCL} - t_{CHCX}$	ns
Rise time	$t_{CLCH}$	–	20	ns
Fall time	$t_{CHCL}$	–	20	ns

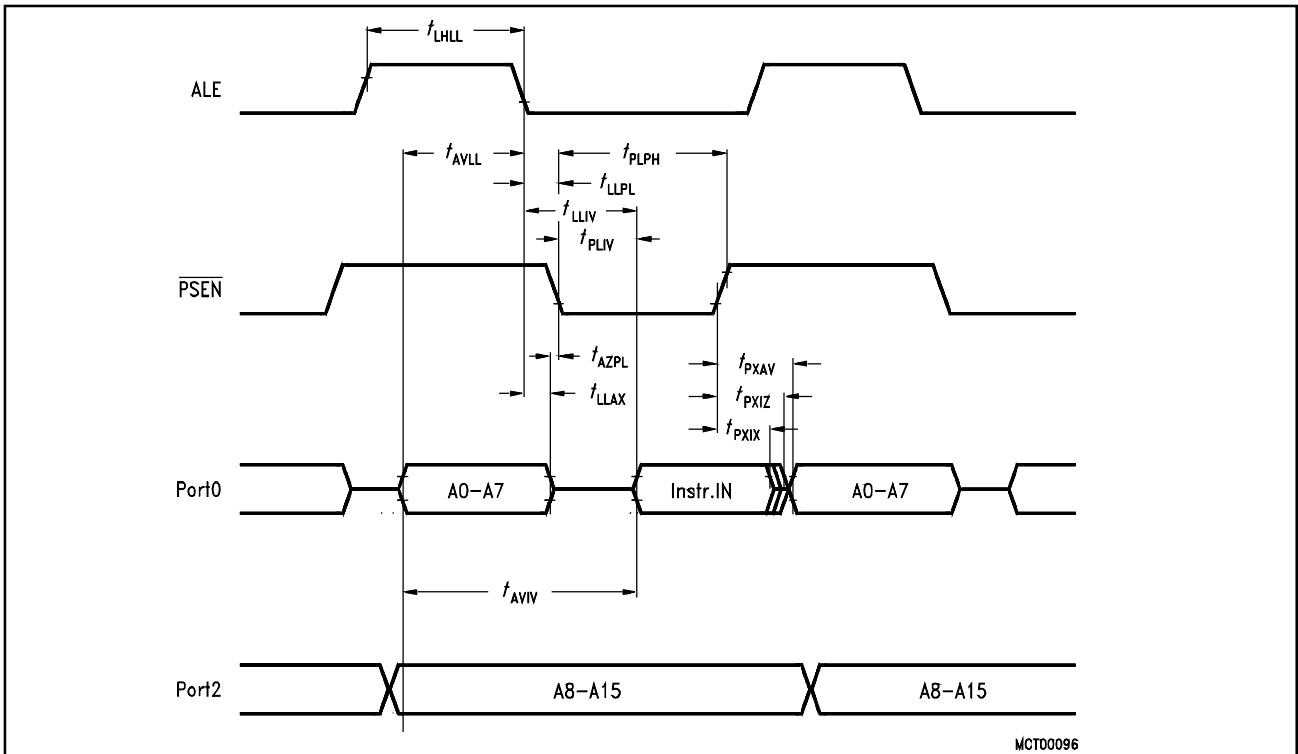

MCT00096

**Figure 11**  
Program Memory Read Cycle

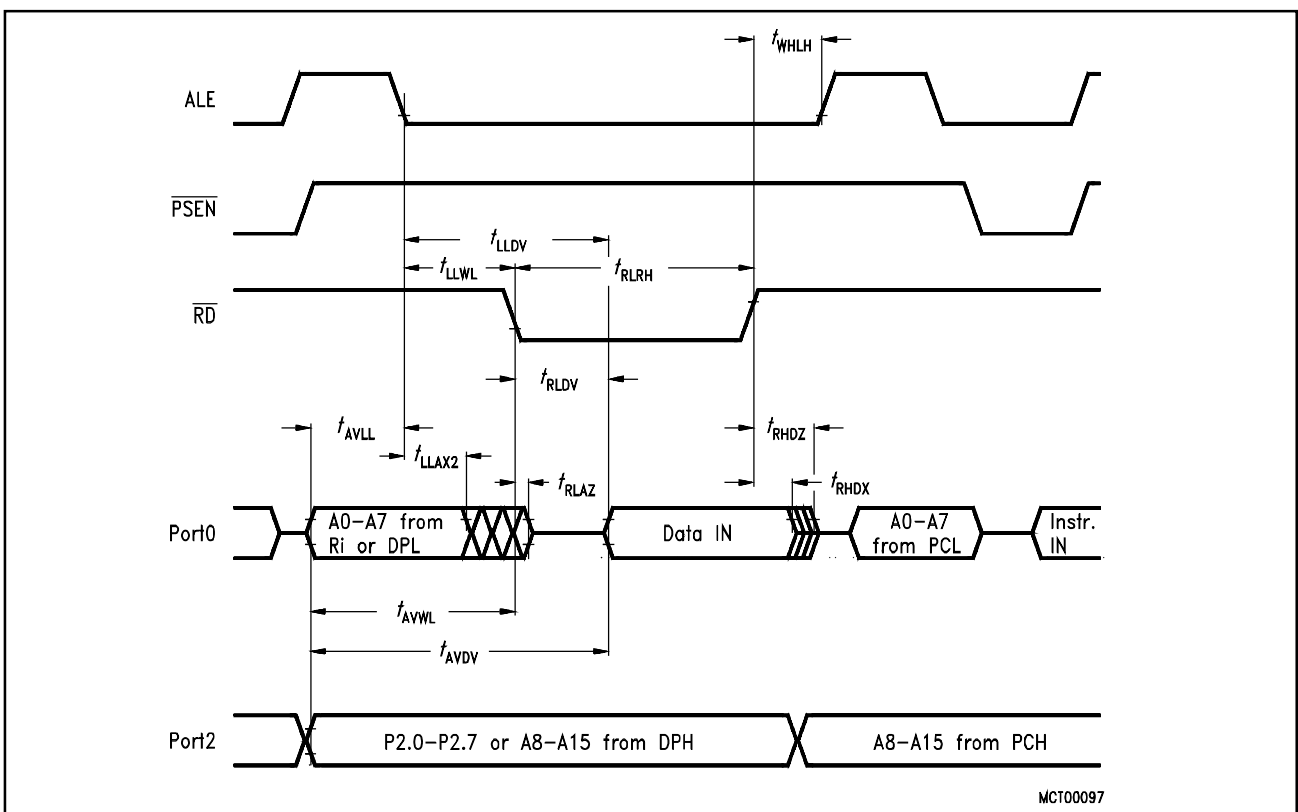

MCT00097

**Figure 12**  
Data Memory Read Cycle

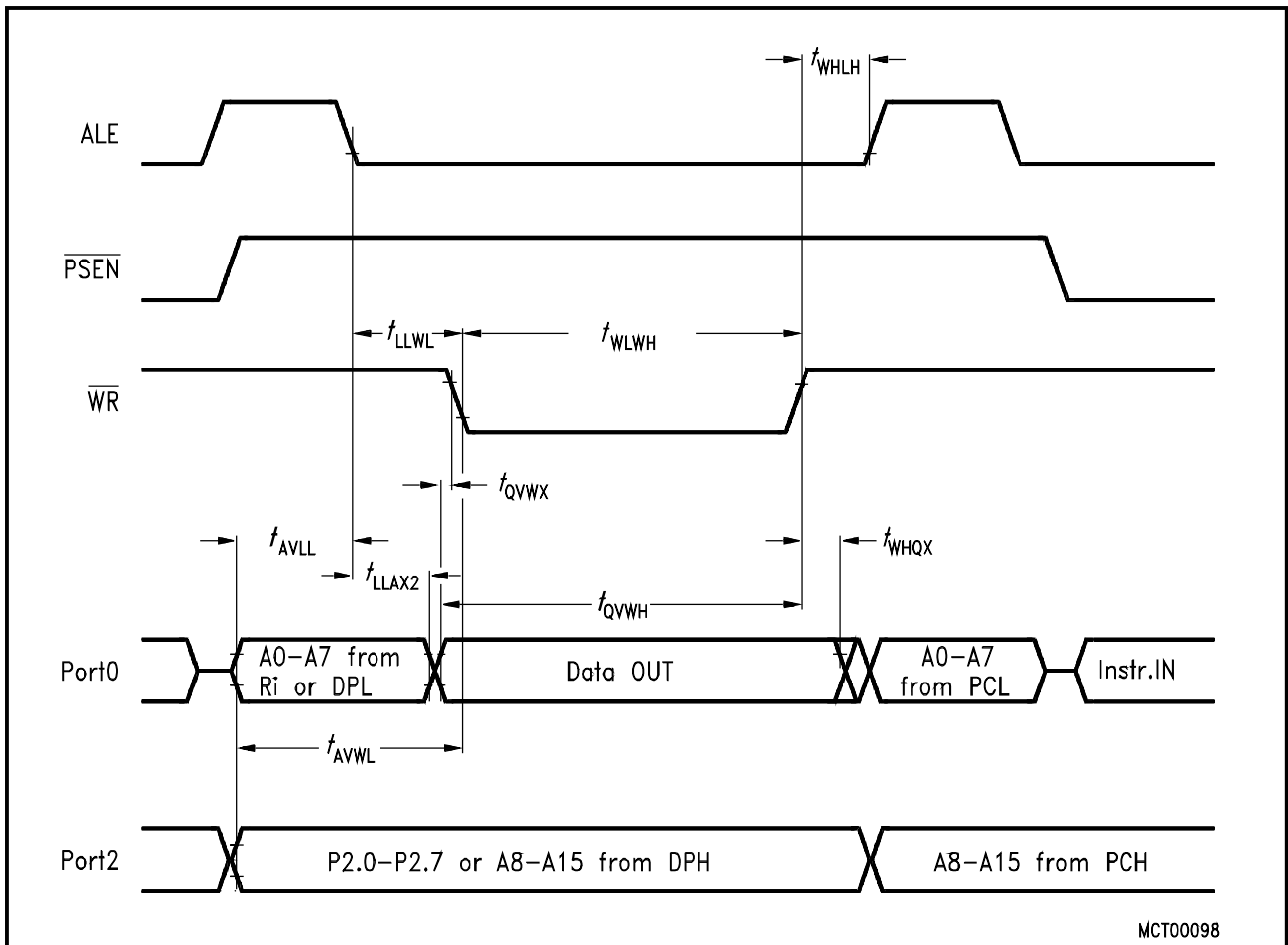

**Figure 13**  
**Data Memory Write Cycle**

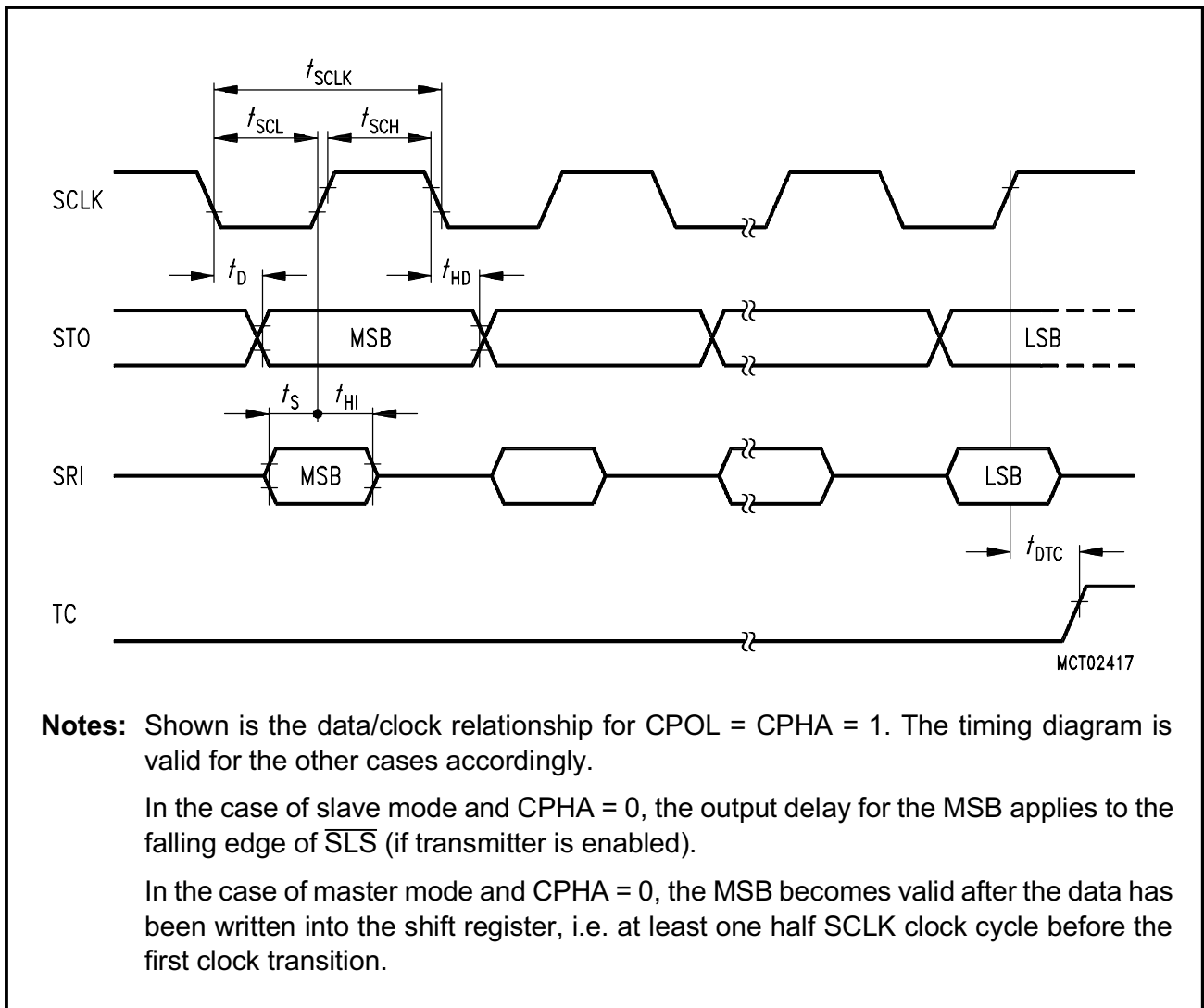

**Figure 14**  
**SSC Timing**

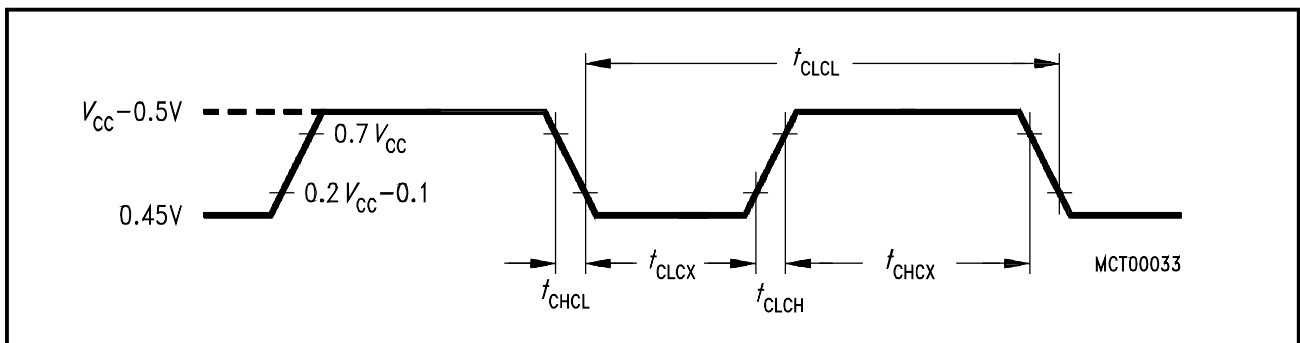

**Figure 15**  
**External Clock Drive at XTAL1**

### ROM Verification Characteristics (only ROM versions C511 / C511A / C513 / C513A)

Parameter	Symbol	Limit Values		Unit
		min.	max.	
Address to valid data	$t_{AVQV}$	—	$48t_{CLCL}$	ns
ENABLE to valid data	$t_{ELQV}$	—	$48t_{CLCL}$	ns
Data float after ENABLE	$t_{EHQZ}$	0	$48t_{CLCL}$	ns
Oscillator frequency	$1/t_{CLCL}$	4	6	MHz

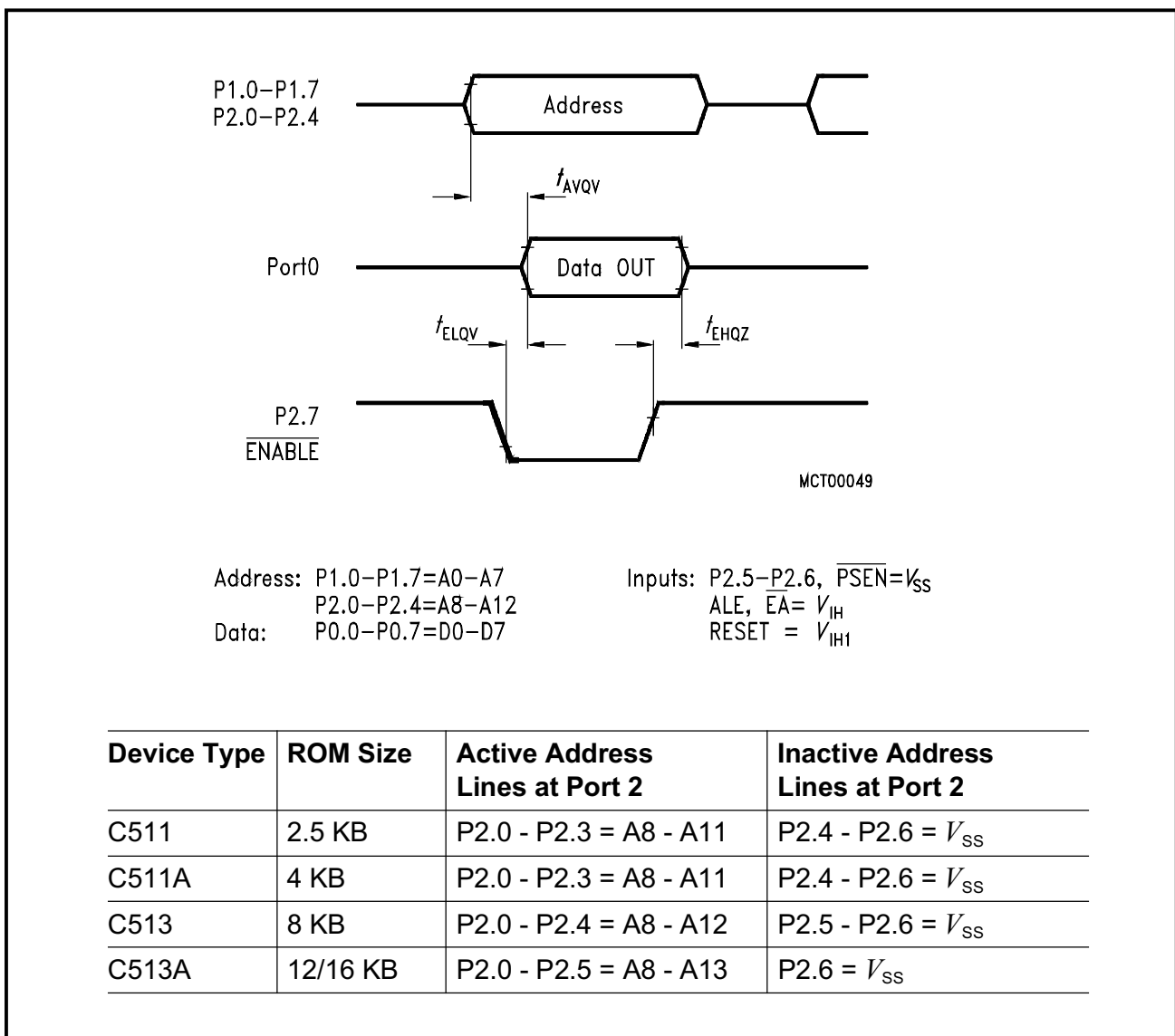

**Figure 16**  
**ROM Verification Timing**

## AC Characteristics of C513A-H Programming Interface

$V_{CC} = 5\text{ V} \pm 10\%$ ,  $V_{SS} = 0\text{ V}$ ;  $T_A = +25\text{ °C} \pm 10\text{ °C}$ ;  $1/t_{CLCL} = 8\text{ MHz}$

Parameter	Symbol	Limit Values		Unit
		min.	max.	
ALE pulse width	$t_{PLL}$	60	–	ns
Address setup to ALE	$t_{PAL}$	20	–	ns
Address hold after ALE	$t_{PLA}$	20	–	ns
Address to valid data out	$t_{PAD}$	–	230	ns
$\overline{\text{PRD}}/\overline{\text{PWR}}$ pulse width	$t_{PCC}$	250	–	ns
$\overline{\text{PRD}}$ to valid data out	$t_{PRDV}$	–	200	ns
Data hold after $\overline{\text{PWR}}$	$t_{PWDH}$	0	–	ns
Data float after $\overline{\text{PRD}}$	$t_{PDZ}$	–	40	ns
Chip select setup to ALE active	$t_{PCS}$	0	–	ns
Chip select hold after $\overline{\text{PRD}}/\overline{\text{PWR}}$ inactive	$t_{PCH}$	0	–	ns
ALE to $\overline{\text{PWR}}$ or $\overline{\text{PRD}}$	$t_{PLC}$	90	–	ns
$\overline{\text{PWR}}$ or $\overline{\text{PRD}}$ high to ALE high	$t_{PCL}$	20	–	ns
Data setup before $\overline{\text{PWR}}$ rising edge	$t_{PWDS}$	50	–	ns
Data hold after $\overline{\text{PWR}}$ rising edge	$t_{PWDH}$	0	–	ns
Data float after $\overline{\text{PCS}}$	$t_{PDF}$	–	40	ns



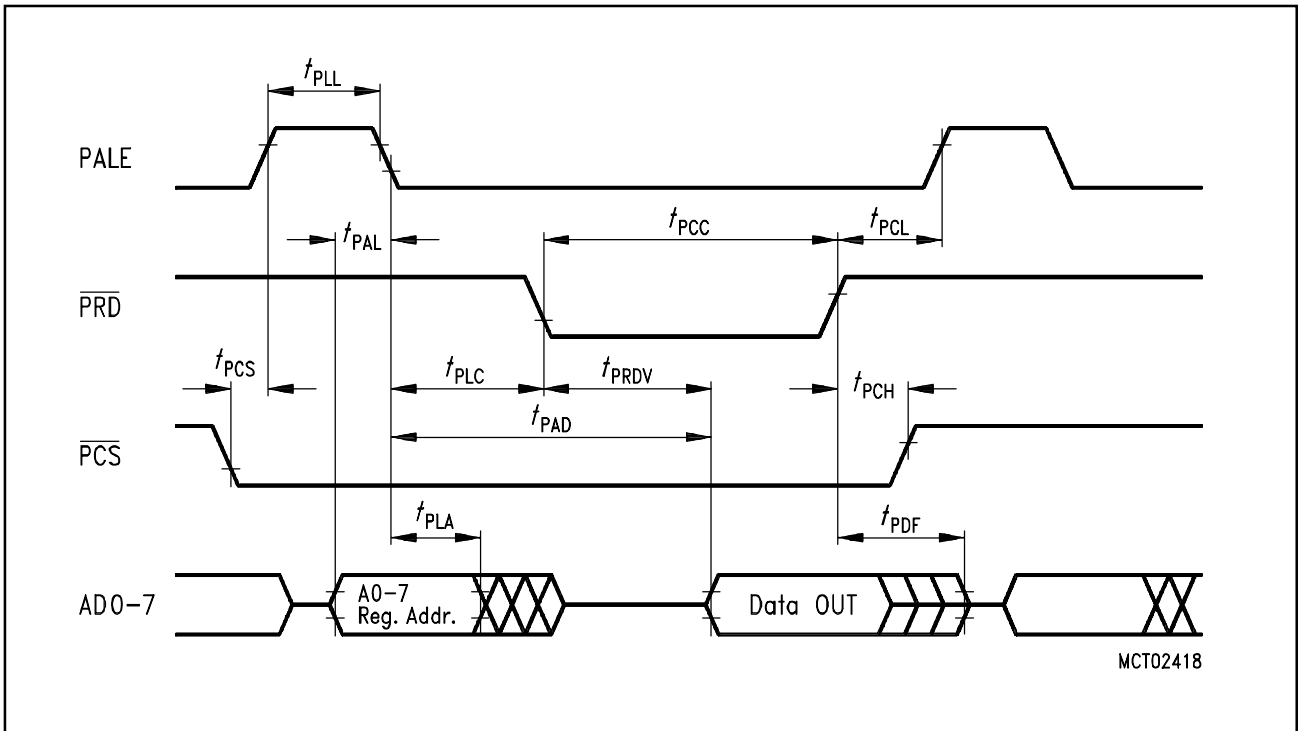

**Figure 17**  
C513A-H Programming Interface Read Cycle

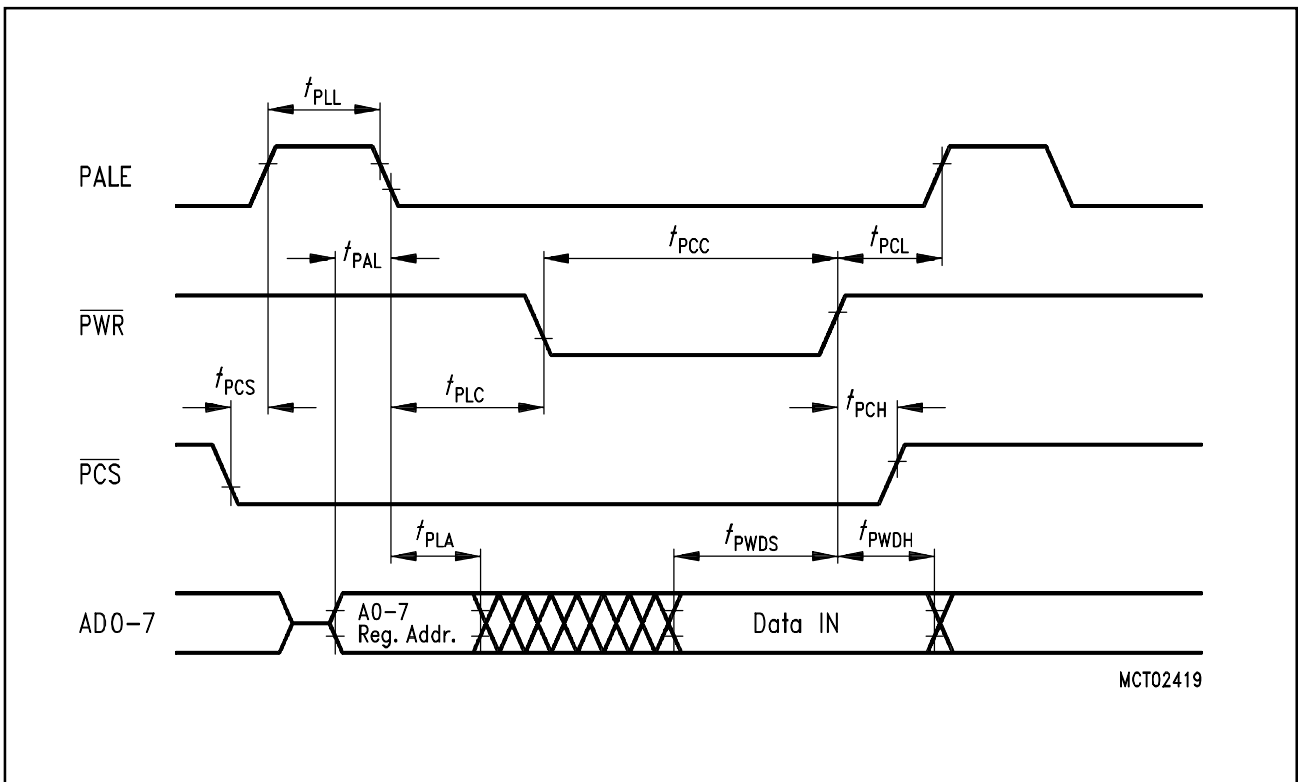

**Figure 18**  
C513A-H Programming Interface Write Cycle

### Reset Characteristics (C513A-H only)

Parameter	Symbol	Limit Values				Unit
		12 MHz Clock		Variable Clock $1/t_{CLCL} = 3.5 \text{ MHz to } 12 \text{ MHz}$		
		min.	max.	min.	max.	
RESET pulse width	$t_{RLRH}$	10	–	10	–	ms

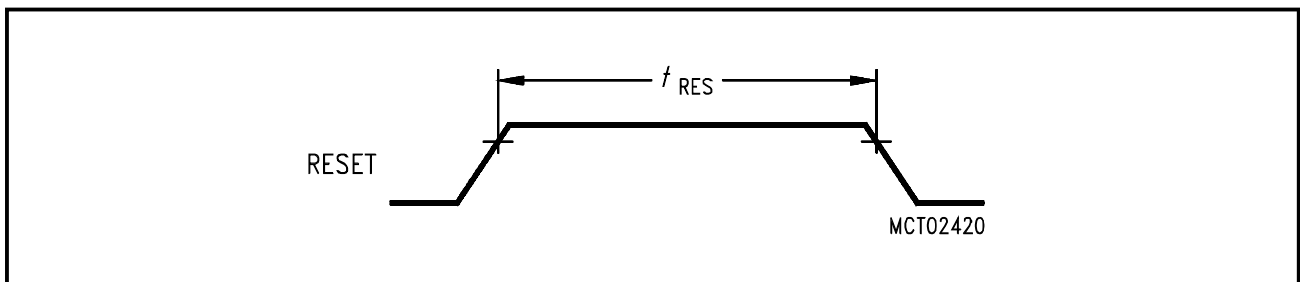

**Figure 19**  
C513A-H Reset Pulse

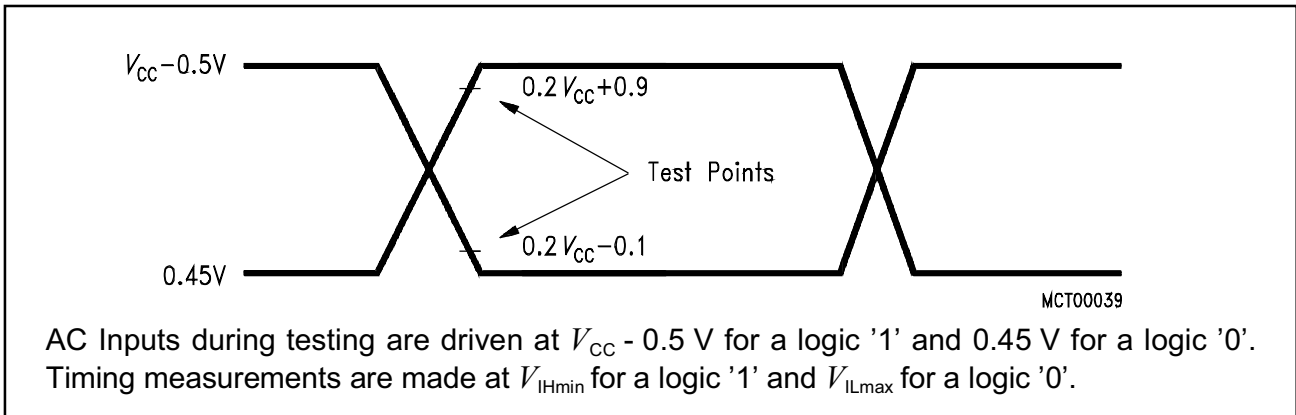

**Figure 20**  
AC Testing: Input, Output Waveforms

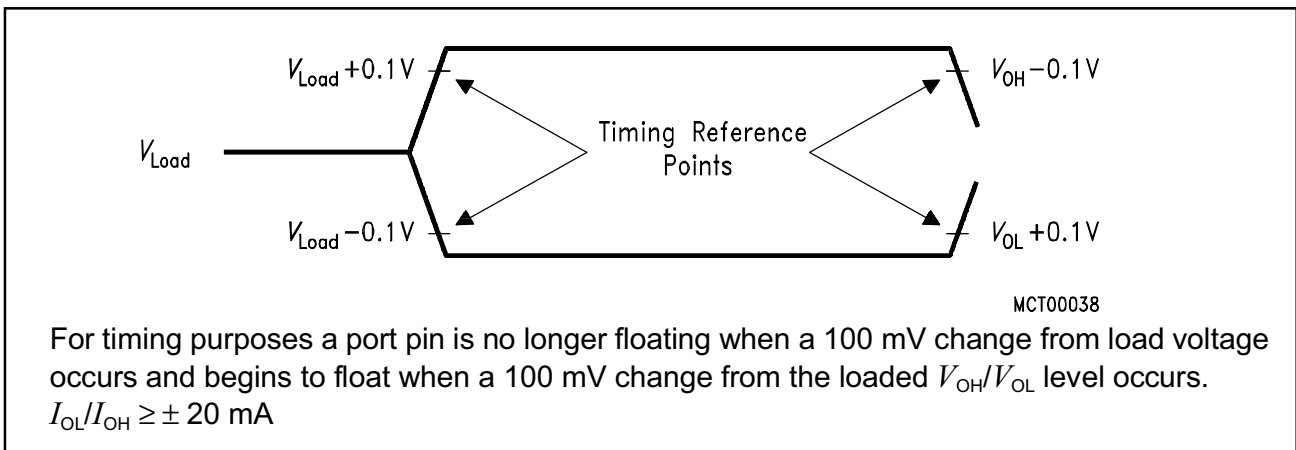

**Figure 21**  
AC Testing: Float Waveforms

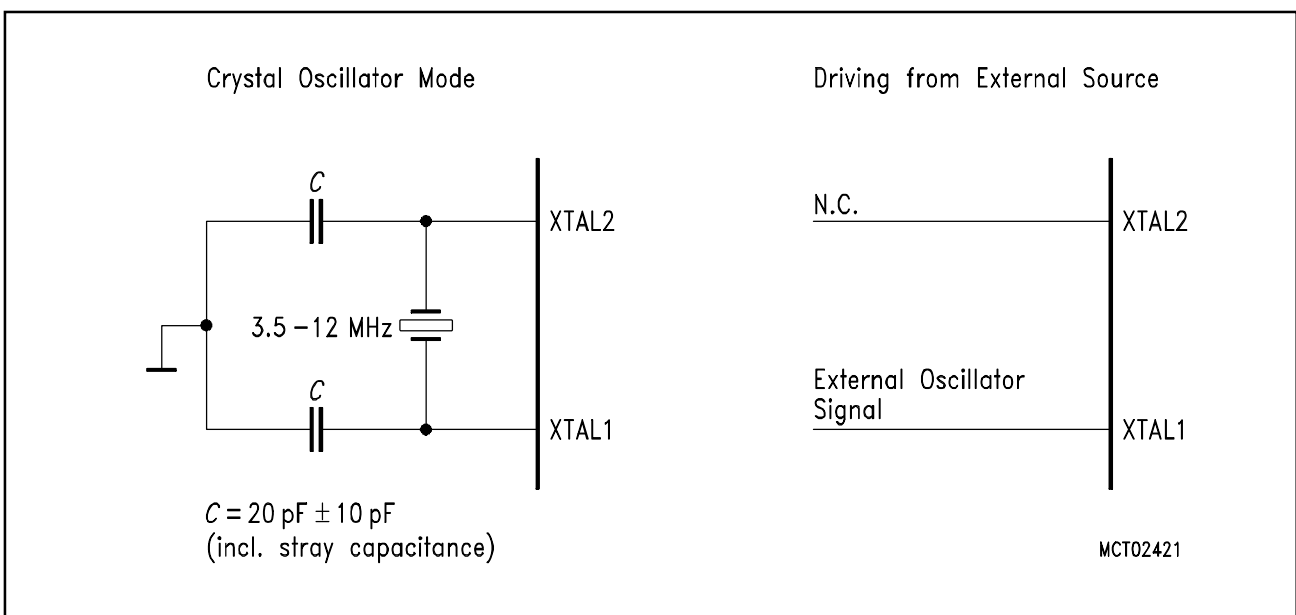

**Figure 22**  
Recommended Oscillator Circuits for Crystal Oscillator