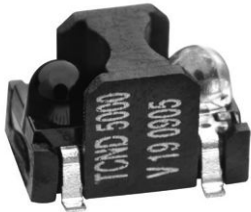
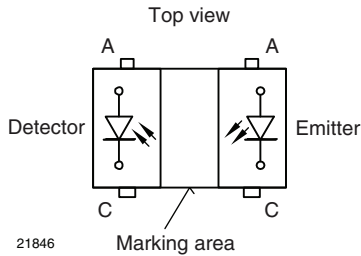


## Reflective Optical Sensor with PIN Photodiode Output



19967



21846

### DESCRIPTION

The TCND5000 is a reflective sensor that includes an infrared emitter and pin photodiode in a surface mount package which blocks visible light.

### FEATURES

- Package type: surface mount
- Detector type: pin photodiode
- Dimensions (L x W x H in mm): 6 x 4.3 x 3.75
- Peak operating distance: 6 mm
- Operating range within > 20 % relative collector current: 2 mm to 25 mm
- Typical output current under test:  $I_{ra} > 0.11 \mu A$
- Daylight blocking filter
- High linearity
- Emitter wavelength: 940 nm
- Lead (Pb)-free soldering released
- Moisture sensitivity level (MSL): 4
- Compliant to RoHS Directive 2002/95/EC and in accordance to WEEE 2002/96/EC


**RoHS**  
COMPLIANT

### APPLICATIONS

- Proximity sensor
- Object sensor
- Motion sensor
- Touch key

### PRODUCT SUMMARY

PART NUMBER	DISTANCE FOR MAXIMUM CTR <sub>rel</sub> <sup>(1)</sup> (mm)	DISTANCE RANGE FOR RELATIVE I <sub>out</sub> > 20 % (mm)	TYPICAL OUTPUT CURRENT UNDER TEST <sup>(2)</sup> (mA)	DAYLIGHT BLOCKING FILTER INTEGRATED
TCND5000	6	2 to 25	0.15	Yes

#### Notes

- (1) CTR: current transference ratio,  $I_{out}/I_{in}$   
 (2) Conditions like in table basic characteristics/sensors

### ORDERING INFORMATION

ORDERING CODE	PACKAGING	VOLUME <sup>(1)</sup>	REMARKS
TCND5000	Tape and reel	MOQ: 2000 pcs, 2000 pcs/reel	Drypack

#### Note

- (1) MOQ: minimum order quantity

### ABSOLUTE MAXIMUM RATINGS (T<sub>amb</sub> = 25 °C, unless otherwise specified)

PARAMETER	TEST CONDITION	SYMBOL	VALUE	UNIT
<b>INPUT (EMITTER)</b>				
Reverse voltage		V <sub>R</sub>	5	V
Forward current		I <sub>F</sub>	100	mA
Peak forward current	t <sub>p</sub> = 50 μs, t = 2 ms, T <sub>amb</sub> ≤ 25 °C	I <sub>FM</sub>	500	mA
Power dissipation		P <sub>V</sub>	190	mW
Junction temperature		T <sub>J</sub>	100	°C

<b>ABSOLUTE MAXIMUM RATINGS</b> ( $T_{amb} = 25\text{ }^{\circ}\text{C}$ , unless otherwise specified)				
PARAMETER	TEST CONDITION	SYMBOL	VALUE	UNIT
<b>OUTPUT (DETECTOR)</b>				
Reverse voltage		$V_R$	60	V
Power dissipation		$P_V$	75	mW
Junction temperature		$T_j$	100	$^{\circ}\text{C}$
<b>SENSOR</b>				
Ambient temperature range		$T_{amb}$	- 40 to + 85	$^{\circ}\text{C}$
Storage temperature range		$T_{stg}$	- 40 to + 100	$^{\circ}\text{C}$
Soldering temperature	acc. fig. 14	$T_{sd}$	260	$^{\circ}\text{C}$

## ABSOLUTE MAXIMUM RATINGS

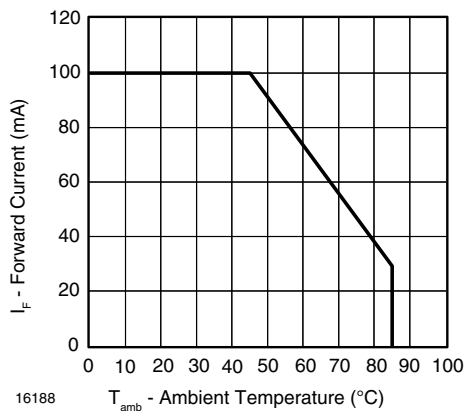


Fig. 1 - Forward Current Limit vs. Ambient Temperature

<b>BASIC CHARACTERISTICS</b> ( $T_{amb} = 25\text{ }^{\circ}\text{C}$ , unless otherwise specified)						
PARAMETER	TEST CONDITION	SYMBOL	MIN.	TYP.	MAX.	UNIT
<b>INPUT (EMITTER) <sup>(1)</sup></b>						
Forward voltage	$I_F = 50\text{ mA}$ , $t_p = 20\text{ ms}$	$V_F$		1.2	1.5	V
Temperature coefficient of $V_F$	$I_F = 1\text{ mA}$	$TK_{V_F}$		- 1.3		mV/K
Reverse current	$V_R = 5\text{ V}$	$I_R$			10	$\mu\text{A}$
Junction capacitance	$V_R = 0\text{ V}$ , $f = 1\text{ MHz}$ , $E = 0\text{ lx}$	$C_j$		25		pF
Radiant intensity	$I_F = 20\text{ mA}$ , $t_p = 20\text{ ms}$	$I_e$		7	75	mW/sr
Angle of half intensity		$\phi$		$\pm 12$		deg
Peak wavelength	$I_F = 100\text{ mA}$	$\lambda_p$	930	940		nm
Spectral bandwidth	$I_F = 100\text{ mA}$	$\Delta\lambda$		50		nm
Temperature coefficient of $\lambda_p$	$I_F = 100\text{ mA}$	$TK_{\lambda_p}$		0.2		nm/K
Rise time	$I_F = 100\text{ mA}$	$t_r$		800		ns
Fall time	$I_F = 100\text{ mA}$	$t_f$		800		ns
Virtual source diameter	Method: 63 % encircled energy	$d$		1.2		mm

<b>BASIC CHARACTERISTICS</b> ( $T_{amb} = 25\text{ }^{\circ}\text{C}$ , unless otherwise specified)						
PARAMETER	TEST CONDITION	SYMBOL	MIN.	TYP.	MAX.	UNIT
<b>OUTPUT (DETECTOR) <sup>(2)</sup></b>						
Forward voltage	$I_F = 50\text{ mA}$	$V_F$		1	1.3	V
Breakdown voltage	$I_R = 100\text{ }\mu\text{A}$	$V_{BR}$	60			V
Reverse dark current	$V_R = 10\text{ V}$ , $E = 0\text{ lx}$	$I_{ro}$		1	10	nA
Diode capacitance	$V_R = 5\text{ V}$ , $f = 1\text{ MHz}$ , $E = 0\text{ lx}$	$C_D$		1.8		pF
Reverse light current	$E_o = 1\text{ mW/cm}^2$ , $\lambda = 950\text{ nm}$ , $V_R = 5\text{ V}$	$I_{ra}$		12		$\mu\text{A}$
Temperature coefficient of $I_{ra}$	$\lambda = 870\text{ nm}$ , $V_R = 5\text{ V}$	$TK_{I_{ra}}$		0.2		%/K
Angle of half intensity		$\phi$		$\pm 15$		deg
Wavelength of peak sensitivity		$\lambda_P$		930		nm
Range of spectral bandwidth		$\lambda_{0.5}$		840 to 1050		nm
<b>SENSOR</b>						
Reverse Light Current	$V_R = 2.5\text{ V}$ , $I_F = 20\text{ mA}$ , $D = 30\text{ mm}$ , reflective mode: see figure 2	$I_{ra}$	110			nA

**Note**

- (1) See figures 2 to 8 accordingly  
 (2) See figures 9 to 12 accordingly

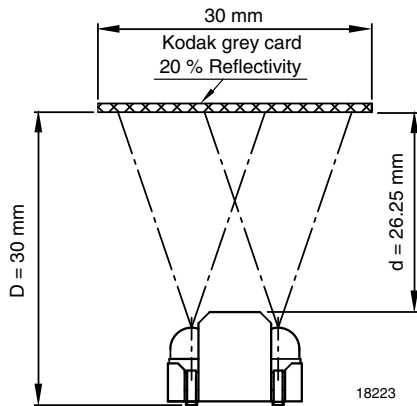


Fig. 2 - Test Circuit

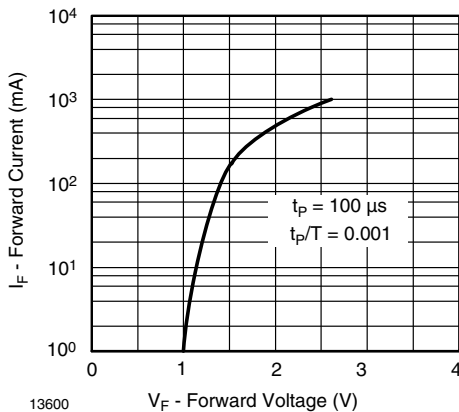
**BASIC CHARACTERISTICS** ( $T_{amb} = 25\text{ }^{\circ}\text{C}$ , unless otherwise specified)


Fig. 3 - Forward Current vs. Forward Voltage

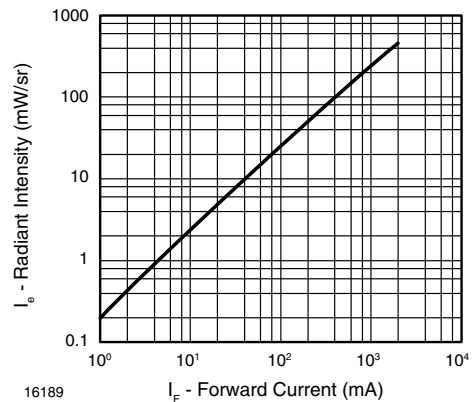


Fig. 4 - Radiant Intensity vs. Forward Current

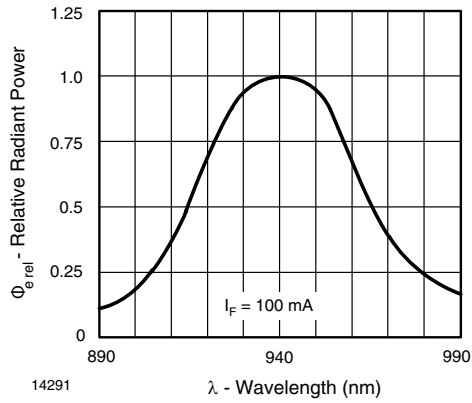


Fig. 5 - Relative Radiant Power vs. Wavelength

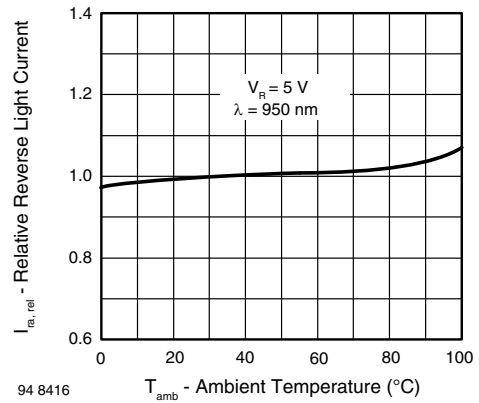


Fig. 8 - Relative Reverse Light Current vs. Ambient Temperature

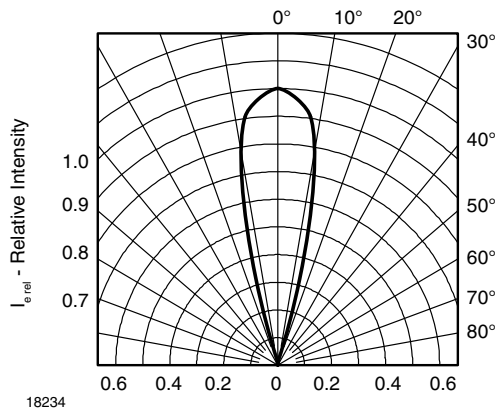


Fig. 6 - Relative Radiant Intensity vs. Angular Displacement

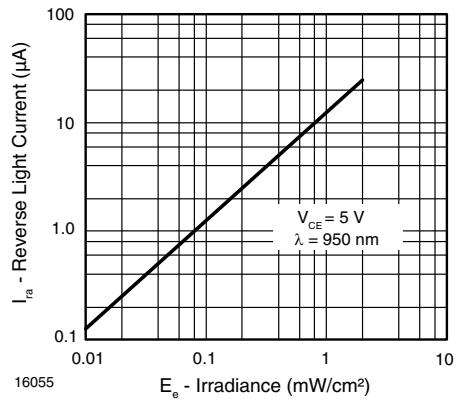


Fig. 9 - Reverse Light Current vs. Irradiance

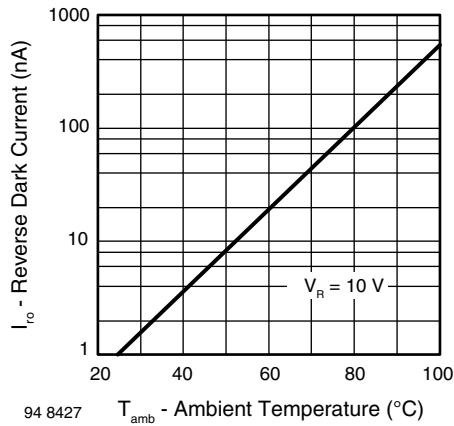


Fig. 7 - Reverse Dark Current vs. Ambient Temperature

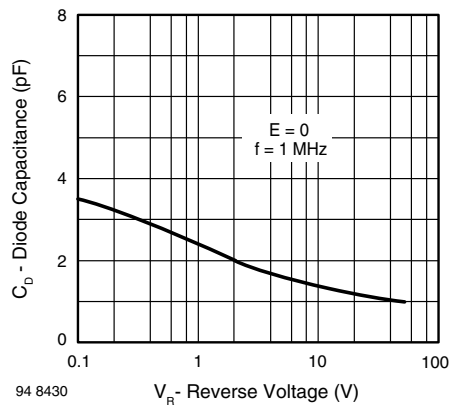
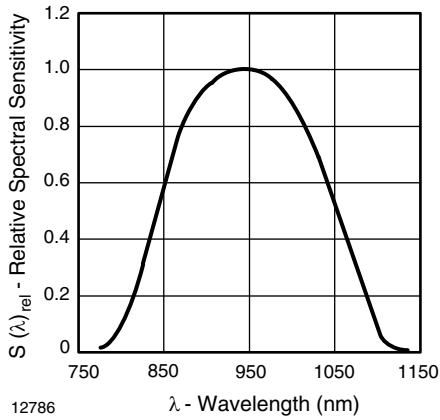
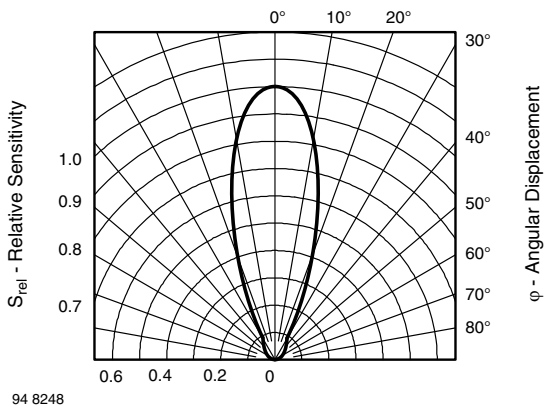


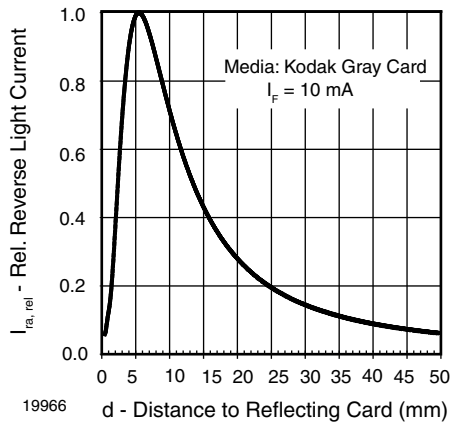
Fig. 10 - Diode Capacitance vs. Reverse Voltage



12786  
Fig. 11 - Relative Spectral Sensitivity vs. Wavelength



94 8248  
Fig. 12 - Relative Radiant Sensitivity vs. Angular Displacement



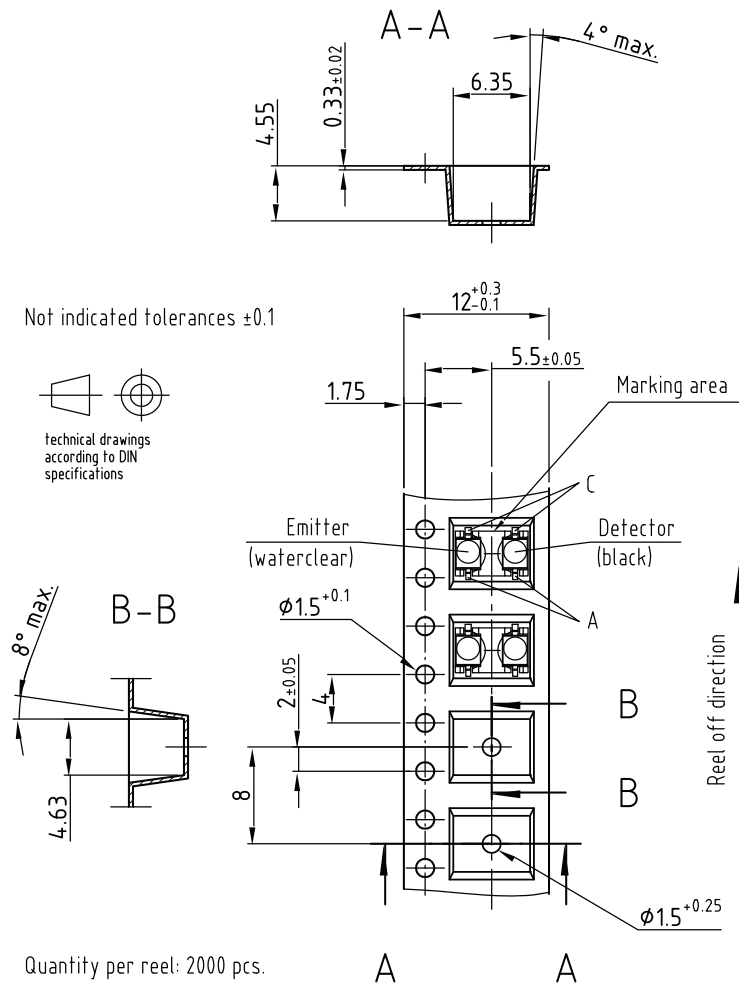
19966  
Fig. 13 - Relative Reverse Light Current vs. Distance

# TCND5000

Vishay Semiconductors Reflective Optical Sensor with PIN  
Photodiode Output

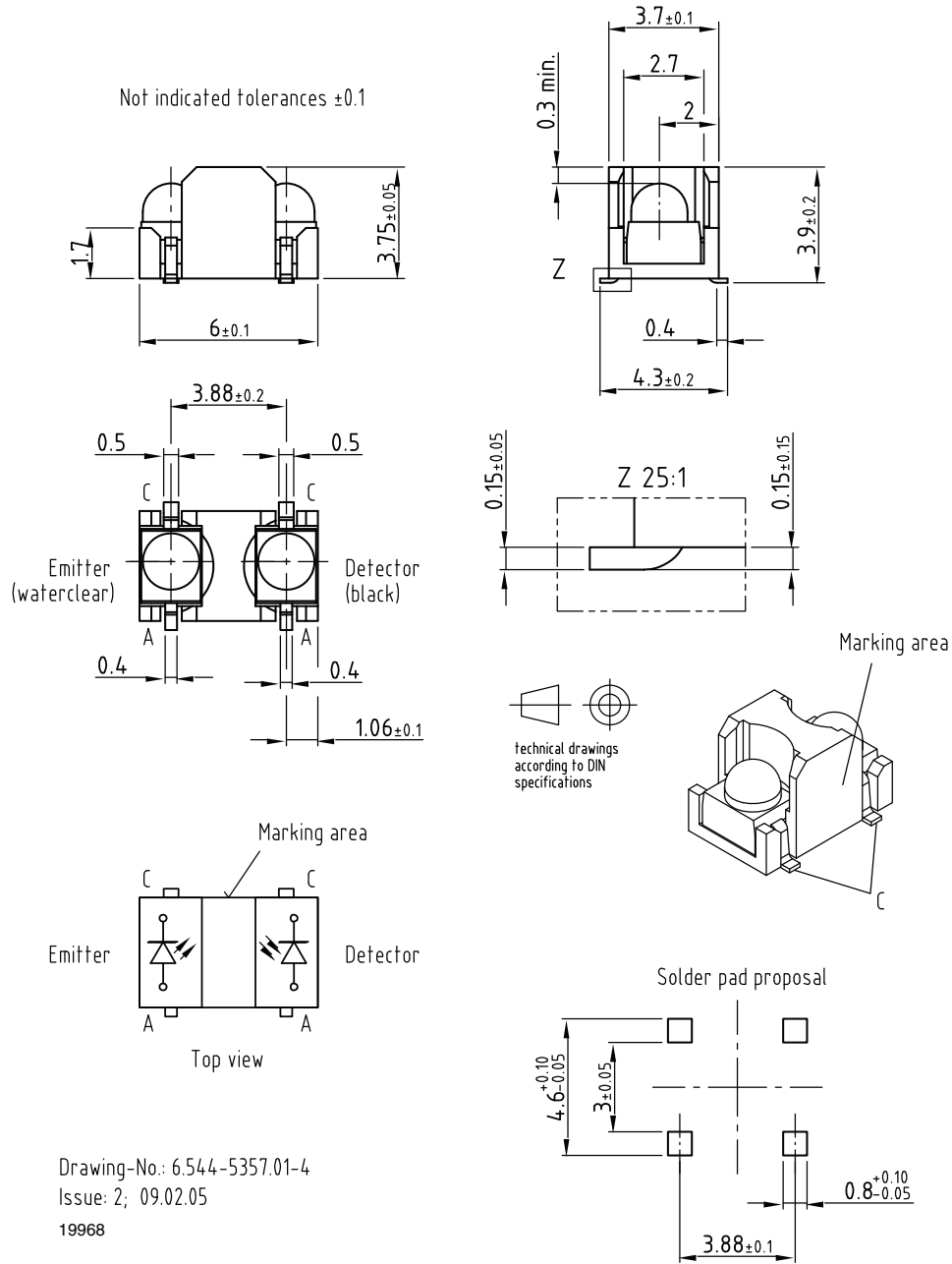


## TAPING Dimensions in millimeters



Material of Blister tape: PC black  
Sealing of cavities with hot sealing cover tape,  
C-Pak Type CP - 2010 AS ( Thickness: 0.055 - 0.075mm; Base Material: Polyester )

Drawing-No.: 9.700-5281.01-4  
Issue: 4; 10.02.05  
18222

**PACKAGE DIMENSIONS** in millimeters


**PRECAUTIONS FOR USE**

**1. Over-current-proof**

Customer must apply resistors for protection, otherwise slight voltage shift will cause big current change (Burn out will happen).

**2. Storage**

2.1 Storage temperature and rel. humidity conditions are: 5 °C to 30 °C, RH 60 %

2.2 Floor life must not exceed 72 h, acc. to JEDEC level 4, J-STD-020.

Once the package is opened, the products should be used within 72 h. Otherwise, they should be kept in a damp proof box with desiccant.

Considering tape life, we suggest to use products within one year from production date.

2.3 If opened more than 72 h in an atmosphere 5 °C to 30 °C, RH 60 %, devices should be treated at 60 °C ± 5 °C for 15 h.

2.4 If humidity indicator in the package shows pink color (normal blue), then devices should be treated with the same conditions as 2.3

**REFLOW SOLDER PROFILES**

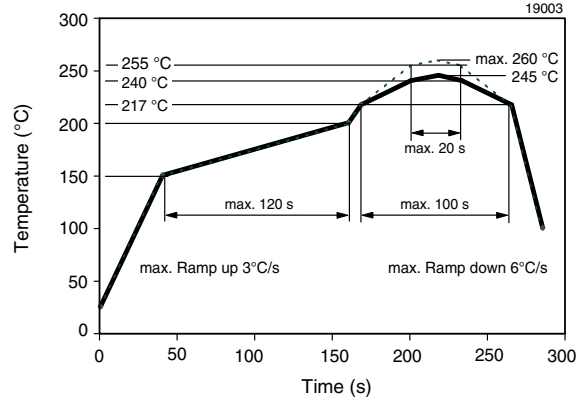


Fig. 14 - Lead (Pb)-Free Reflow Solder Profile

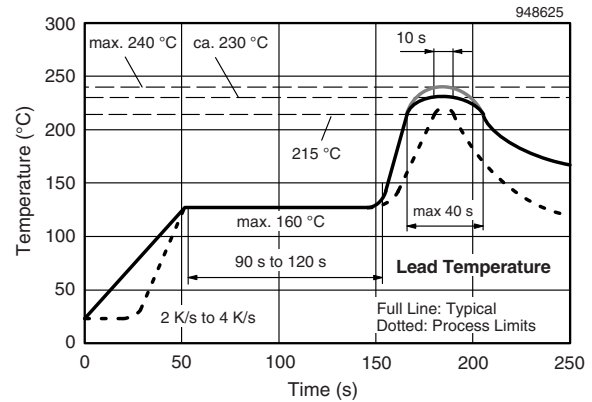


Fig. 15 - Lead Tin (SnPb) Reflow Solder Profile





## Disclaimer

All product specifications and data are subject to change without notice.

Vishay Intertechnology, Inc., its affiliates, agents, and employees, and all persons acting on its or their behalf (collectively, "Vishay"), disclaim any and all liability for any errors, inaccuracies or incompleteness contained herein or in any other disclosure relating to any product.

Vishay disclaims any and all liability arising out of the use or application of any product described herein or of any information provided herein to the maximum extent permitted by law. The product specifications do not expand or otherwise modify Vishay's terms and conditions of purchase, including but not limited to the warranty expressed therein, which apply to these products.

No license, express or implied, by estoppel or otherwise, to any intellectual property rights is granted by this document or by any conduct of Vishay.

The products shown herein are not designed for use in medical, life-saving, or life-sustaining applications unless otherwise expressly indicated. Customers using or selling Vishay products not expressly indicated for use in such applications do so entirely at their own risk and agree to fully indemnify Vishay for any damages arising or resulting from such use or sale. Please contact authorized Vishay personnel to obtain written terms and conditions regarding products designed for such applications.

Product names and markings noted herein may be trademarks of their respective owners.