



PROGRAMMABLE VOLTAGE REFERENCE

- ADJUSTABLE OUTPUT VOLTAGE :
2.5 to 36V
- SINK CURRENT CAPABILITY : 1 to 100mA
- TYPICAL OUTPUT IMPEDANCE : 0.22Ω
- 1% AND 2% VOLTAGE PRECISION

DESCRIPTION

The TL431 is a programmable shunt voltage reference with guaranteed temperature stability over the entire temperature range of operation. The output voltage may be set to any value between 2.5V and 36V with two external resistors. The TL431 operates with a wide current range from 1 to 100mA with a typical dynamic impedance of 0.22Ω.

ORDER CODE

Part Number	Temperature Range	Package	
		Z	D
TL431C/AC	0°C, +70°C	•	•
TL431I/AI	-40°C, +105°C	•	•

Z = TO92 Plastic package - also available in Bulk (Z), Tape & Reel (ZT) and Ammo Pack (AP)
 D = Small Outline Package (SO) - also available in Tape & Reel (DT)

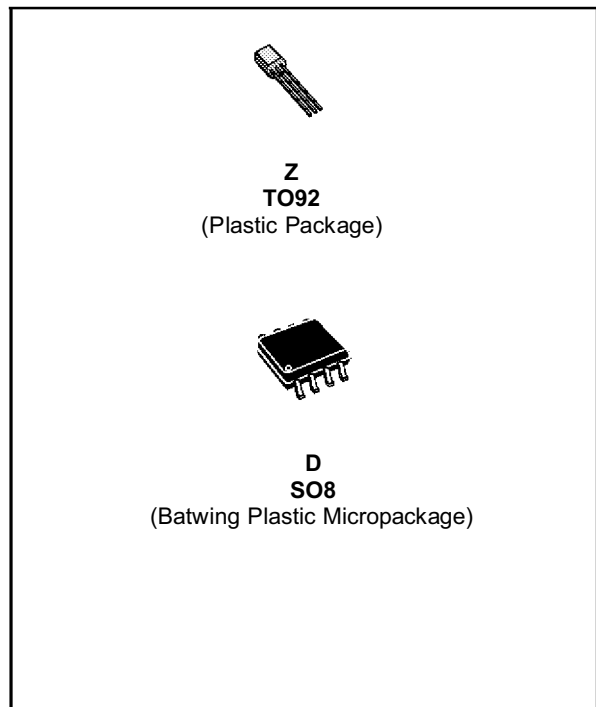

PIN CONNECTIONS (top view)

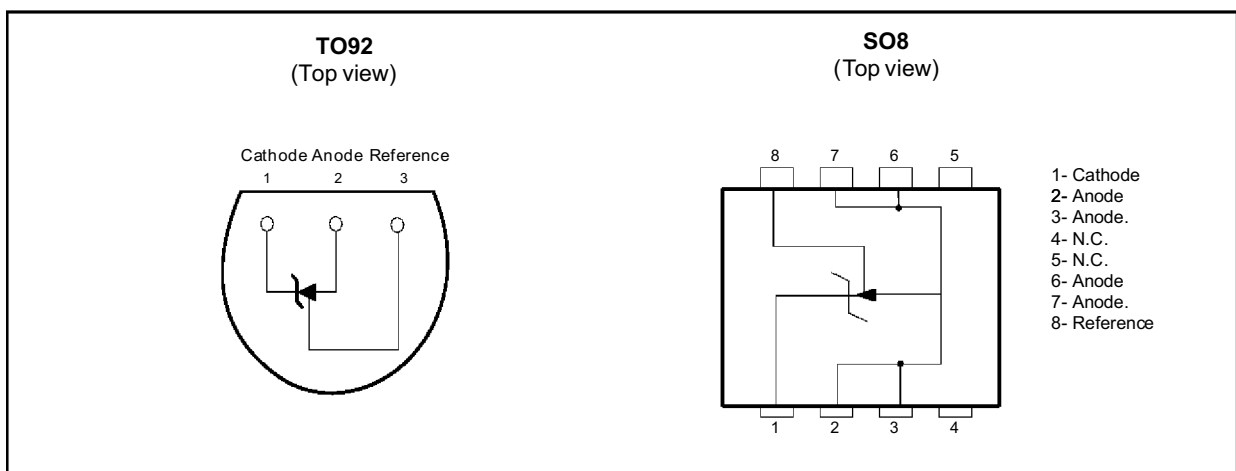

TL431

ABSOLUTE MAXIMUM RATINGS

Symbol	Parameter	Value	Unit	
V_{KA}	Cathode to Anode Voltage	37	V	
I_k	Continuous Cathode Current Range	-100 to +150	mA	
I_{ref}	Reference Input Current Range	-0.05 to +10	mA	
P_d	Power Dissipation ¹⁾	TO92 SO8 batwing	625 960	mW
T_{stg}	Storage Temperature Range	-65 to +150	°C	

1. P_d is calculated with $T_{amb} = +25^\circ\text{C}$, $T_j = +150^\circ\text{C}$ and $R_{thja} = 200^\circ\text{C/W}$ for TO92 package
 $= 130^\circ\text{C/W}$ for SO8 batwing package

OPERATING CONDITIONS

Symbol	Parameter	Value	Unit
V_{KA}	Cathode to Anode Voltage	V_{ref} to 36	V
I_k	Cathode Current	1 to 100	mA
T_{oper}	Operating Free-air Temperature Range TL431C/AC TL431I/AI	0 to +70 -40 to +105	°C

ELECTRICAL CHARACTERISTICS

$T_{amb} = 25^\circ\text{C}$ (unless otherwise specified)

Symbol	Parameter	TL431C			TL431AC			Unit
		Min.	Typ.	Max.	Min.	Typ.	Max.	
V_{ref}	Reference Input Voltage $V_{KA} = V_{ref}$, $I_k = 10\text{ mA}$ $T_{amb} = 25^\circ\text{C}$ $T_{min} \leq T_{amb} \leq T_{max}$	2.44 2.423	2.495	2.55 2.567	2.47 2.453	2.495	2.52 2.537	V
ΔV_{ref}	Reference Input Voltage Deviation Over-Temperature Range - note 1 $V_{KA} = V_{ref}$, $I_k = 10\text{ mA}$, $T_{min} \leq T_{amb} \leq T_{max}$		3	17		3	15	mV
$\frac{\Delta V_{ref}}{\Delta V_{KA}}$	Ratio of Change in Reference Input Voltage to Change in Cathode to Anode Voltage - (figure 2) $I_k = 10\text{ mA}$ $\Delta V_{KA} = 10\text{ V to } V_{ref}$ $\Delta V_{KA} = 36\text{ V to } 10\text{ V}$		-1.4 -1	-2.7 -2		-1.4 -1	-2.7 -2	mV/V
I_{ref}	Reference Input Current $I_k = 10\text{ mA}$, $R_1 = 10\text{ k}\Omega$, $R_2 = \infty$ $T_{amb} = 25^\circ\text{C}$ $T_{min} \leq T_{amb} \leq T_{max}$		1.8	4 5.2		1.8	4 5.2	μA
ΔI_{ref}	Reference Input Current Deviation Over Temperature Range $I_k = 10\text{ mA}$, $R_1 = 10\text{ k}\Omega$, $R_2 = \infty$ $T_{min} \leq T_{amb} \leq T_{max}$		0.4	1.2		0.4	1.2	μA
I_{min}	Minimum Cathode Current for Regulation $V_{KA} = V_{ref}$		0.5	1		0.5	0.6	mA
I_{off}	Off-State Cathode Current		2.6	1000		2.6	1000	nA
$ Z_{KA} $	Dynamic Impedance - note 2 $V_{KA} = V_{ref}$, $\Delta I_k = 1\text{ to }100\text{ mA}$, $f \leq 1\text{ kHz}$		0.22	0.5		0.22	0.5	Ω

1) ΔV_{ref} is defined as the difference between the maximum and minimum values obtained over the full temperature range.

$$\Delta V_{ref} = V_{ref\ max.} - V_{ref\ min.}$$

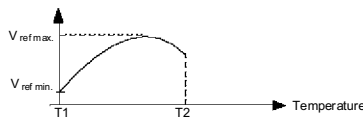

2) The dynamic Impedance is defined as $|Z_{KA}| = \frac{\Delta V_{KA}}{\Delta I_k}$

ELECTRICAL CHARACTERISTICS

T_{amb} = 25°C (unless otherwise specified)

Symbol	Parameter	TL431I			TL431AI			Unit
		Min.	Typ.	Max.	Min.	Typ.	Max.	
V _{ref}	Reference Input Voltage V _{KA} = V _{ref} , I _k = 10 mA, T _{amb} = 25°C T _{min} ≤ T _{amb} ≤ T _{max}	2.44 2.41	2.495	2.55 2.58	2.47 2.44	2.495	2.52 2.55	V
ΔV _{ref}	Reference Input Voltage Deviation Over-Temperature Range - note 1 V _{KA} = V _{ref} , I _k = 10 mA, T _{min} ≤ T _{amb} ≤ T _{max}		7	30		7	30	mV
$\frac{\Delta V_{ref}}{\Delta V_{ka}}$	Ratio of Change in Reference Input Voltage to Change in Cathode to Anode Voltage I _k = 10 mA ΔV _{KA} = 10V to V _{ref} ΔV _{KA} = 36V to 10V		-1.4 -1	-2.7 -2		-1.4 -1	-2.7 -2	mV/V
I _{ref}	Reference Input Current I _k = 10 mA, R ₁ = 10kΩ, R ₂ = ∞ T _{amb} = 25°C T _{min} ≤ T _{amb} ≤ T _{max}		1.8	4 6.5		1.8	4 6.5	μA
ΔI _{ref}	Reference Input Current Deviation Over Temperature Range I _k = 10 mA, R ₁ = 10kΩ, R ₂ = ∞ T _{min} ≤ T _{amb} ≤ T _{max}		0.8	2.5		0.8	1.2	μA
I _{min}	Minimum Cathode Current for Regulation V _{KA} = V _{ref}		0.5	1		0.5	0.7	mA
I _{off}	Off-State Cathode Current		2.6	1000		2.6	1000	nA
Z _{KA}	Dynamic Impedance note 2 V _{KA} = V _{ref} , ΔI _k = 1 to 100 mA, f ≤ 1 kHz		0.22	0.5		0.22	0.5	Ω

1) ΔV_{ref} is defined as the difference between the maximum and minimum values obtained over the full temperature range.
 $\Delta V_{ref} = V_{ref\ max.} - V_{ref\ min.}$

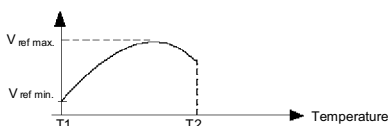

2) The dynamic Impedance is defined as $|Z_{KA}| = \frac{\Delta V_{KA}}{\Delta I_K}$

Figure 1 : Test Circuit for $V_{KA} = V_{REF}$

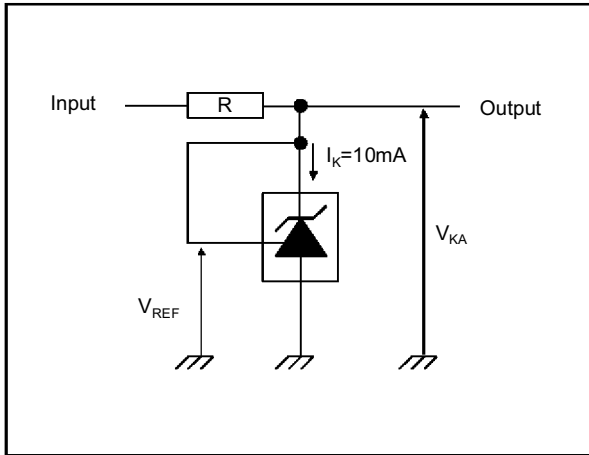

Figure 3 : Test Circuit for I_{OFF}

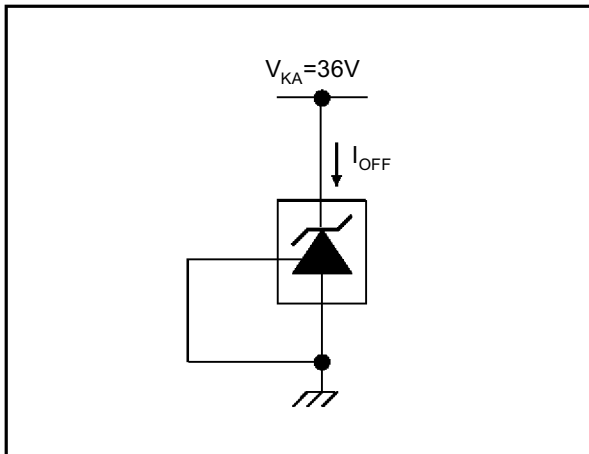

Figure 5 : Block diagram of TL431

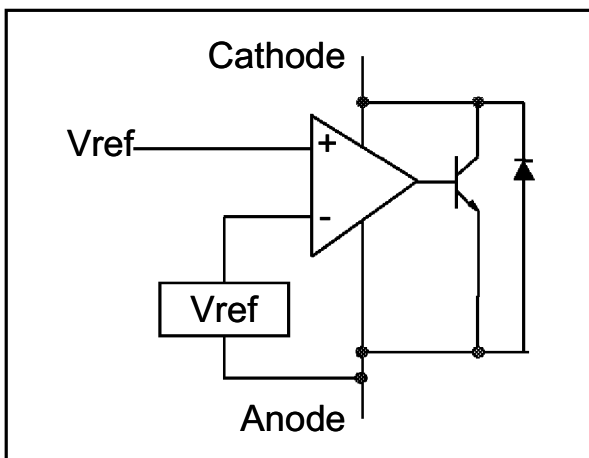

Figure 2 : Test Circuit for $V_{KA} > V_{REF}$

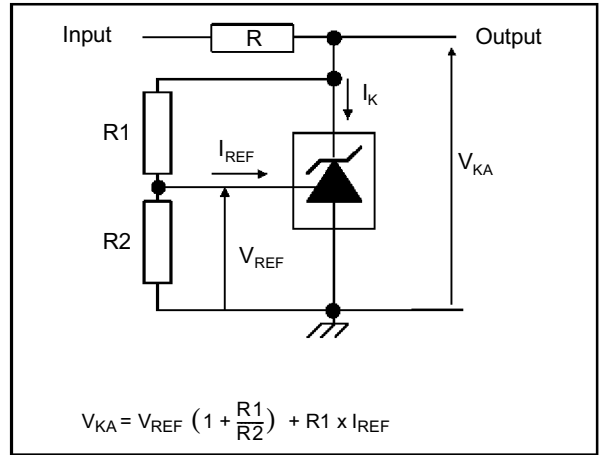

Figure 4 : Test Circuit for Phase Margin and Voltage Gain

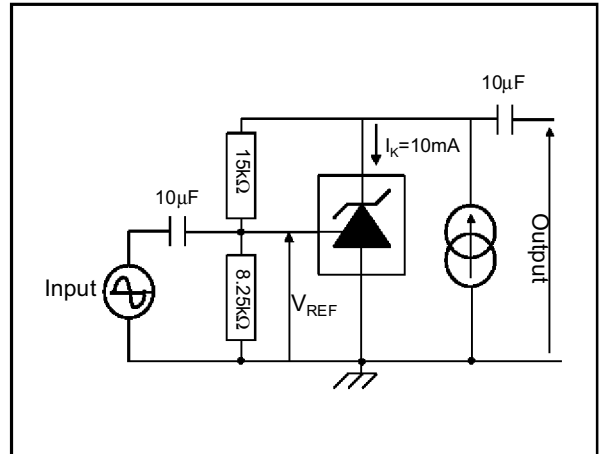
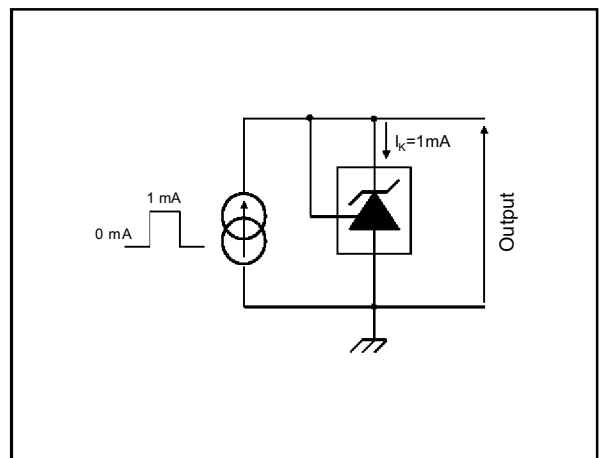
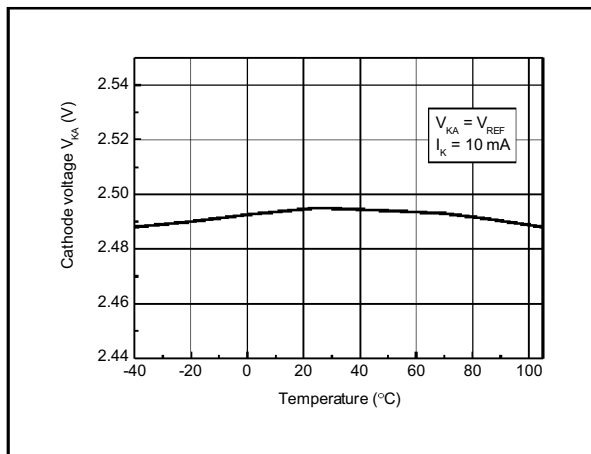

Figure 6 : Test Circuit for Response time



Reference voltage vs Temperature



Reference voltage vs cathode current

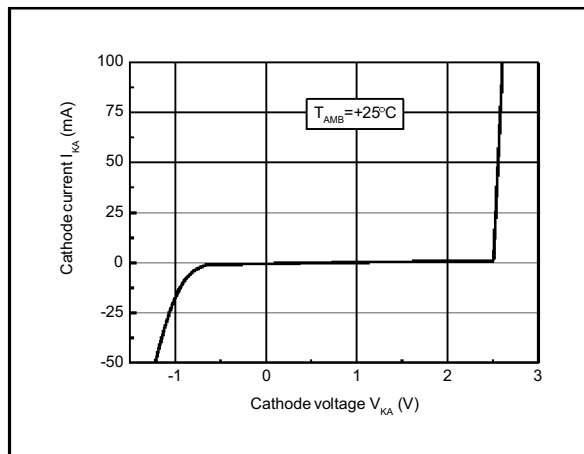

Reference voltage vs cathode current

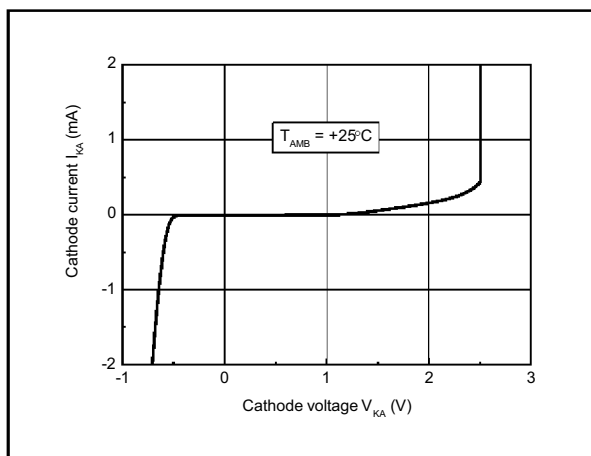

Reference current vs temperature

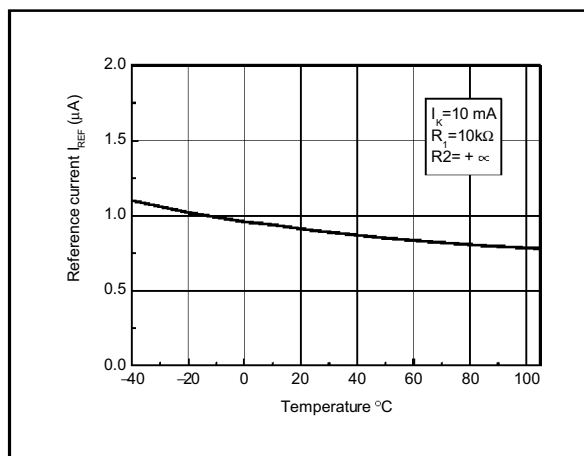

Off-state cathode current vs temperature

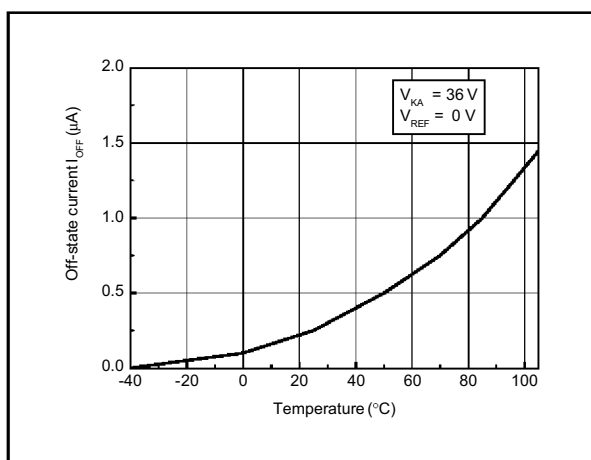

Ratio of change in V_{REF} to change in V_{KA} vs Temperature

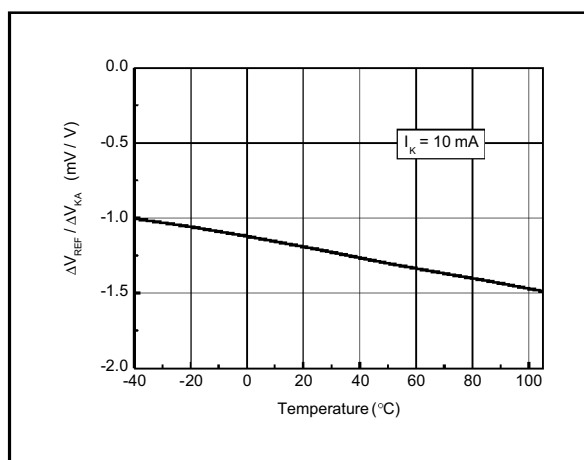

Static impedance R_{KA} vs Temperature

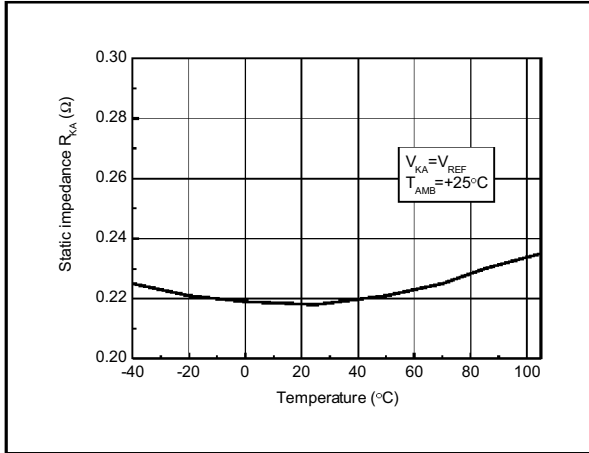

Minimum operating current vs temperature

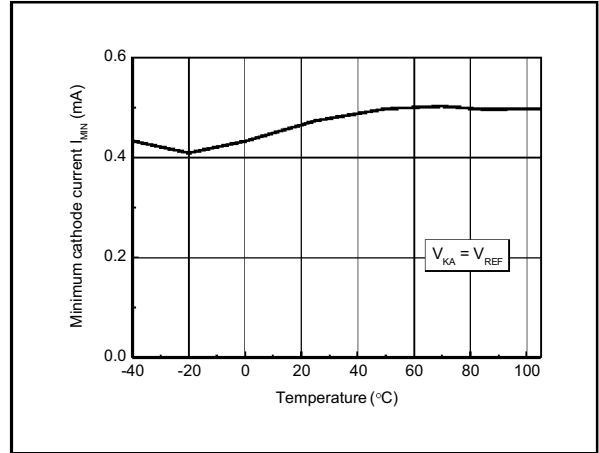

Gain & Phase vs Frequency

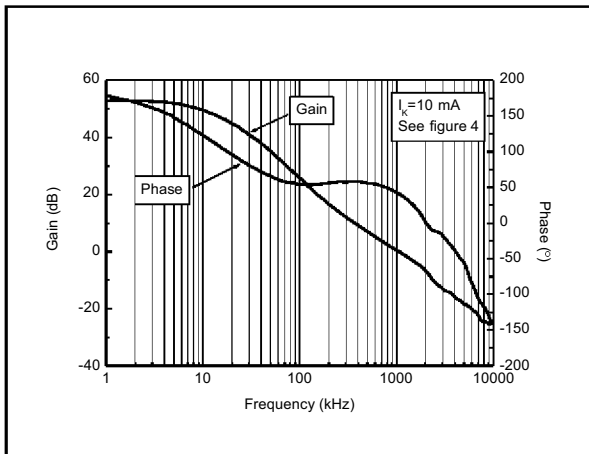

Stability behaviour with capacitive loads

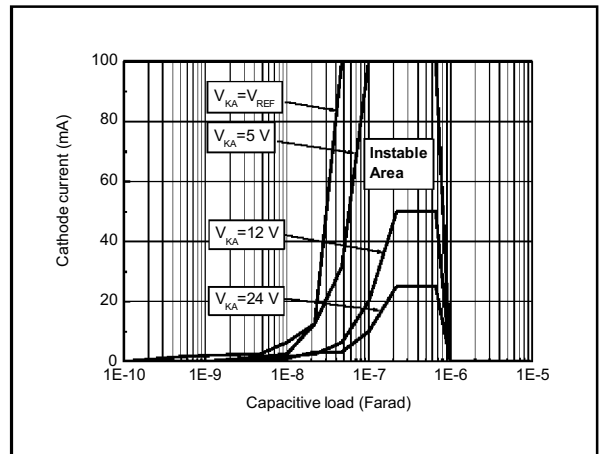

Maximum Power dissipation

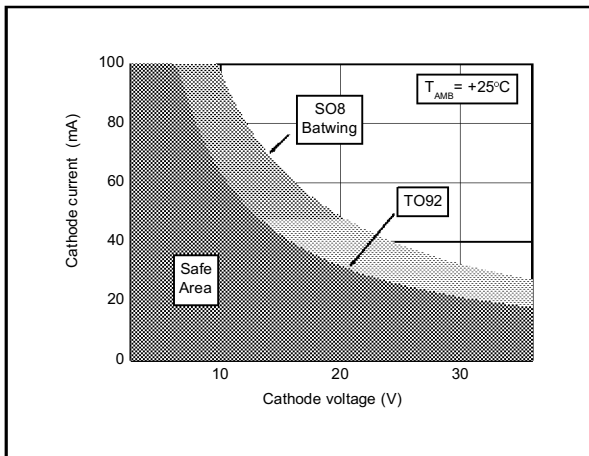

Pulse response for $I_K=1\text{mA}$

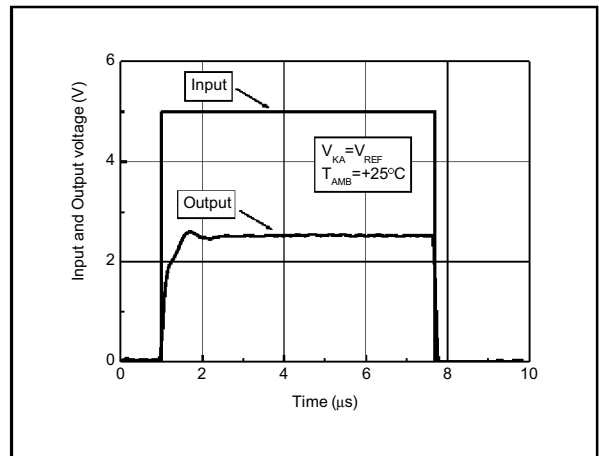

PACKAGE MECHANICAL DATA
 8 PINS - BATWING PLASTIC MICROPACKAGE (SO)

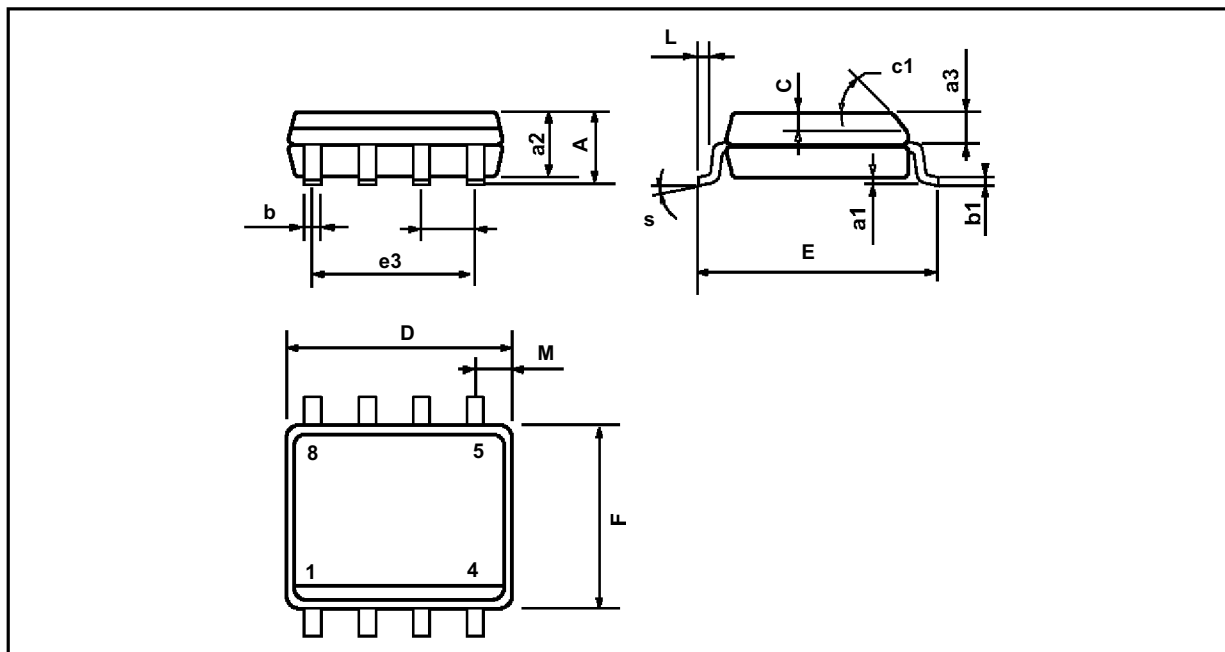

Dim.	Millimeters			Inches		
	Min.	Typ.	Max.	Min.	Typ.	Max.
A			1.75			0.069
a1	0.1		0.25	0.004		0.010
a2			1.65			0.065
a3	0.65		0.85	0.026		0.033
b	0.35		0.48	0.014		0.019
b1	0.19		0.25	0.007		0.010
C	0.25		0.5	0.010		0.020
c1	45° (typ.)					
D	4.8		5.0	0.189		0.197
E	5.8		6.2	0.228		0.244
e		1.27			0.050	
e3		3.81			0.150	
F	3.8		4.0	0.150		0.157
L	0.4		1.27	0.016		0.050
M			0.6			0.024
S	8° (max.)					

PACKAGE MECHANICAL DATA

3 PINS - PLASTIC PACKAGE TO92 (TAPE & REEL)

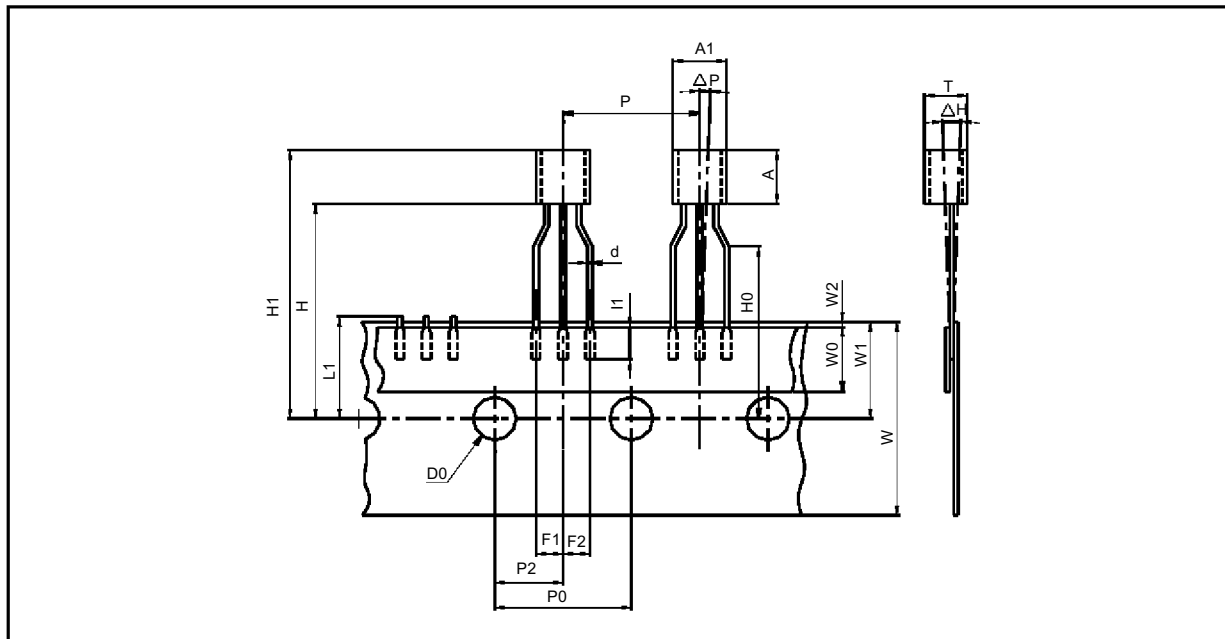

Dim.	Millimeters			Inches		
	Min	Typ.	Max.	Min.	Typ.	Max.
AL			5.0			0.197
A			5.0			0.197
T			4.0			0.157
d		0.45			0.018	
I1	2.5			0.098		
P	11.7	12.7	13.7	0.461	0.500	0.539
PO	12.4	12.7	13	0.488	0.500	0.512
P2	5.95	6.35	6.75	0.234	0.250	0.266
F1/F2	2.4	2.5	2.8	0.094	0.098	0.110
Δh	-1	0	1	-0.039	0	0.039
ΔP	-1	0	1	-0.039	0	0.039
W	17.5	18.0	19.0	0.689	0.709	0.748
W0	5.7	6	6.3	0.224	0.236	0.248
W1	8.5	9	9.75	0.335	0.354	0.384
W2			0.5			0.020
H			20			0.787
H0	15.5	16	16.5	0.610	0.630	0.650
H1			25			0.984
DO	3.8	4.0	4.2	0.150	0.157	0.165
L1			11			0.433

PACKAGE MECHANICAL DATA

3 PINS - PLASTIC PACKAGE TO92 (TAPE AMMO PACK)

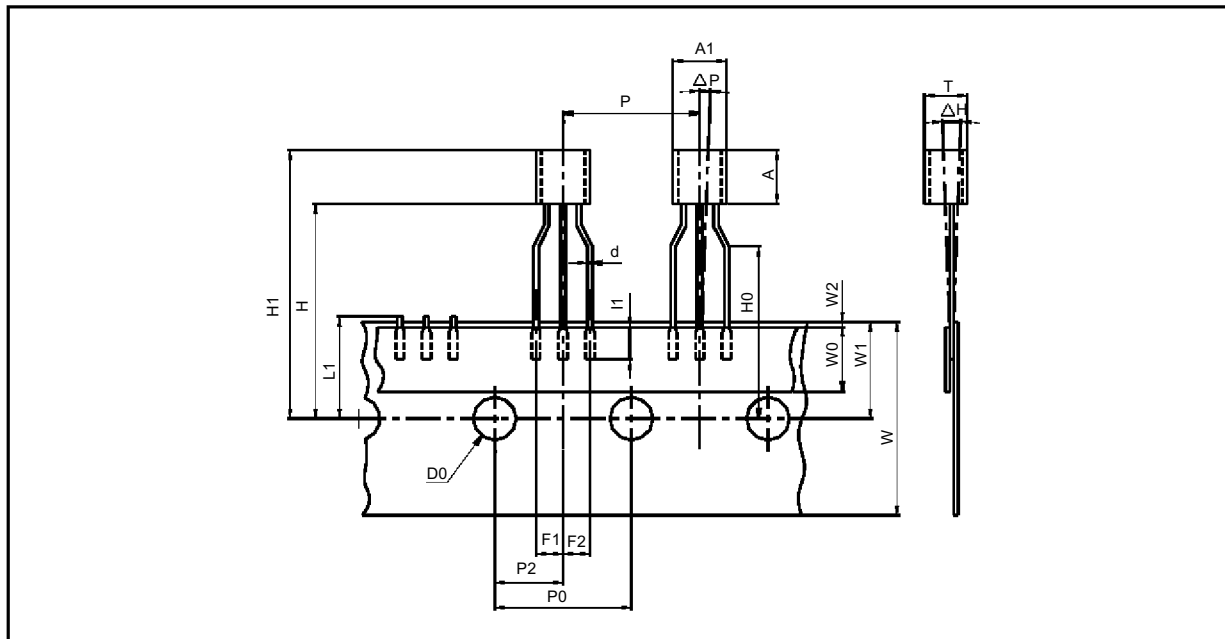

Dim.	Millimeters			Inches		
	Min	Typ.	Max.	Min.	Typ.	Max.
AL			5.0			0.197
A			5.0			0.197
T			4.0			0.157
d		0.45			0.018	
I1	2.5			0.098		
P	11.7	12.7	13.7	0.461	0.500	0.539
PO	12.4	12.7	13	0.488	0.500	0.512
P2	5.95	6.35	6.75	0.234	0.250	0.266
F1/F2	2.4	2.5	2.8	0.094	0.098	0.110
Δh	-1	0	1	-0.039	0	0.039
ΔP	-1	0	1	-0.039	0	0.039
W	17.5	18.0	19.0	0.689	0.709	0.748
W0	5.7	6	6.3	0.224	0.236	0.248
W1	8.5	9	9.75	0.335	0.354	0.384
W2			0.5			0.020
H			20			0.787
H0	15.5	16	16.5	0.610	0.630	0.650
H1			25			0.984
DO	3.8	4.0	4.2	0.150	0.157	0.165
L1			11			0.433

PACKAGE MECHANICAL DATA
3 PINS - PLASTIC PACKAGE TO92 (BULK)

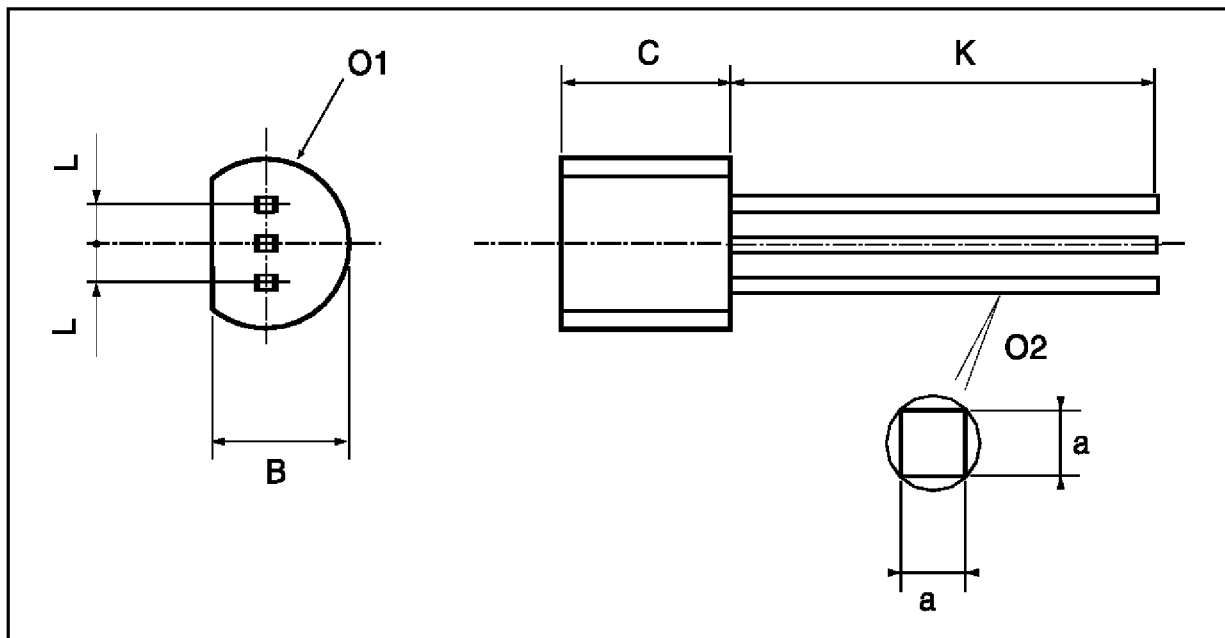

Dim.	Millimeters			Inches		
	Min	Typ.	Max.	Min.	Typ.	Max.
L		1.27			0.05	
B	3.2	3.7	4.2	0.126	0.1457	0.1654
O1	4.45	5.00	5.2	0.1752	0.1969	0.2047
C	4.58	5.03	5.33	0.1803	0.198	0.2098
K	12.7			0.5		
O2	0.407	0.5	0.508	0.016	0.0197	0.02
a	0.35			0.0138		

Information furnished is believed to be accurate and reliable. However, STMicroelectronics assumes no responsibility for the consequences of use of such information nor for any infringement of patents or other rights of third parties which may result from its use. No license is granted by implication or otherwise under any patent or patent rights of STMicroelectronics. Specifications mentioned in this publication are subject to change without notice. This publication supersedes and replaces all information previously supplied. STMicroelectronics products are not authorized for use as critical components in life support devices or systems without express written approval of STMicroelectronics.

© The ST logo is a registered trademark of STMicroelectronics

© 2002 STMicroelectronics - Printed in Italy - All Rights Reserved
STMicroelectronics GROUP OF COMPANIES

Australia - Brazil - Canada - China - Finland - France - Germany - Hong Kong - India - Israel - Italy - Japan - Malaysia
Malta - Morocco - Singapore - Spain - Sweden - Switzerland - United Kingdom - United States

© <http://www.st.com>