

2. TRANZYSTORY

Wykaz oznaczeń parametrów technicznych

C_{CBO}	pojemność kolektor - baza
C_{12es}	pojemność sprzężenia zwrotnego w układzie wspólnego emitera /OE/
C_{12ss}	pojemność sprzężenia zwrotnego w układzie wspólnego źródła /OS/
f_p	częstotliwość pomiarowa
f_T	częstotliwość graniczna
F	współczynnik szumów
h_{21e}	małosygnałowy zwarciovowy współczynnik przeniesienia prądowego w OE
I_B	prąd bazy
I_C	prąd kolektora
I_D	prąd drenu
I_{DSS}	prąd drenu przy zwarciu bramka - źródło / $U_{GS} = 0$ / i przy określonym U_{DS}
I_G	prąd bramki
P_C	moc strat w kolektorze
P_{tot}	moc całkowita
$r_{bb} C_c$	stała czasowa sprzężenia zwrotnego przy w.cz.
t_{amb}	temperatura otoczenia
t_{case}	temperatura obudowy
t_j	temperatura złącza
t_{off}	czas wyłączenia
t_{on}	czas włączania
t_s	czas przełączania
U_{CB}	napięcie kolektor - baza
U_{CBO}	napięcie kolektor - baza, otwarty emiter
U_{CE}	napięcie kolektor - emiter
U_{CEO}	napięcie kolektor - emiter, otwarta baza
U_{CES}	napięcie kolektor - emiter, baza swarta
U_{EBO}	napięcie emiter - baza, otwarty kolektor
U_{DS}	napięcie dren - źródło
U_{GD}	napięcie bramka - dren
U_{GS}	napięcie stałe bramka - źródło
$U_{GS\ off}$	napięcie odcięcie bramka - źródło

2.1. Tranzystory małej częstotliwości małej mocy

Oznaczenie wyrobu	Parametry dopuszczalne / $t_{amb} = 25^{\circ}C$ /								Grupa	U_C I min
	U_{CBO}	U_{CEO}	U_{EBO}	I_C	P_{tot}	t_j	t_{amb}	t_{stg}		
	V	V	V	mA	mW	$^{\circ}C$	$^{\circ}C$	$^{\circ}C$		
	max	max	max	max	max	max				
1	2	3	4	5	6	7	8	9	10	
BC 107	50	45	5	100	300	175	-40 ... +125	-55 ... +150	A B	110 200
BC 108	30	20	5	100	300	175	-40 ... +125	-55 ... +150	A B C	110 200 400
BC 109	30	20	5	100	300	175	-40 ... +125	-55 ... +150	B C	200 400
BC 147	50	45	6	100	300	125	-40 ... +125	-55 ... +125	A B	110 200
BC 148	30	20	5	100	300	125	-40 ... +125	-55 ... +125	A B C	110 200 400
BC 149	30	20	5	100	300	125	-40 ... +125	-55 ... +125	B C	200 400
BC 157	50	45	5	100	300	125	-40 ... +125	-55 ... +125	VI A	65 110
BC 158	30	25	5	100	300	125	-40 ... +125	-55 ... +125	VI A B	65 110 200
BC 159	25	20	5	100	300	125	-40 ... +125	-55 ... +125	A B	110 200
BC 177	50	45	5	100	300	175	-40 ... +125	-55 ... +175	VI A B	65 110 200
BC 178	30	25	5	100	300	175	-40 ... +125	-55 ... +175	VI A B	65 110 200
BC 179	25	20	5	100	300	175	-40 ... +125	-55 ... +175	A B	110 200
BC 211	80	40	5	1000	800	175	-40 ... +125	-65 ... +175	6 10 16	40 ^{2/} 60 ^{2/} 100 ^{2/}

Parametry charakterystyczne / $t_{amb} = 25^{\circ}C$ /										N	Zastosowanie	Obudowa
h_{21E}		h_{21e}		f_T	C_{CBO} przy		$U_{CE sat}$		F			
CE = 5 V $I_C = 2$ mA		$U_{CE} = 5$ V $I_C = 2$ mA $f = 1$ kHz			MHz	pF	U_{CB} / U_{CE}	V				
/typ/	max	min	max	min /typ/					max /typ/			
11	12			13	14	15	16	17	18	19	20	
	240 480	125 240	260 500	150	6	10	0,25	10	N	a	CE 22	
	240 480 850	125 240 450	260 500 900	150	6	10	0,25	10	N	a	CE 22	
	480 850	240 450	500 900	150	6	10	0,25	4	N	b	CE 22	
	240 480	125 240	260 500	150	4,5	10	0,25	10	N	c	CE 36	
	240 480 850	125 240 450	260 500 900	150	4,5	10	0,25	10	N	c	CE 36	
	480 850	240 450	500 900	150	4,5	10	0,25	4	N	b	CE 36	
	150 240	75 125	150 260	/150/	6	10	0,2	10	P	c	CE 36	
	150 240 480	75 125 240	150 260 500	/150/	6	10	0,2	10	P	c	CE 36	
	240 480	125 240	260 500	/150/	6	10	0,2	4	P	b	CE 36	
	150 240 480	75 125 240	150 260 500	100	7	10	/0,1/	10	P	c	CE 22	
	150 240 480	75 125 240	150 260 500	100	7	10	/0,1/	10	P	c	CE 22	
	240 480	125 240	260 500	100	7	10	/0,1/	4	P	b	CE 22	
1/ 2/ 2/	100 ² / 160 ² / 250 ² / 2/			50	25	/10/	1 ³ / 2/		N	e	CE 23	

1	2	3	4	5	6	7	8	9	10	11	
BC 211 A	100	60	5	1000	800	175	-40 ... +125	-65 ... +175	6 10 16	40 ² / ₂ 60 ² / ₂ 100 ² / ₂	100 ² / ₂ 160 ² / ₂ 250 ² / ₂
BC 237	45	45	6	100	300	150	-25 ... +85	-55 ... +150	A B	110 200	240 480
BC 238	20	20	5	100	300	150	-25 ... +85	-55 ... +150	A B C	110 200 450	240 480 900
BC 239	20	20	5	100	300	150	-25 ... +85	-55 ... +150	B C	200 450	480 900
BC 307	50	45	5	100	300	150	-25 ... +85	-55 ... +150	VI A	65 110	150 240
BC 308	30	25	5	100	300	150	-25 ... +85	-55 ... +150	VI A B	65 110 200	150 240 480
BC 309	25	20	5	100	300	150	-25 ... +85	-55 ... +150	A B	110 200	240 480
BC 313	60	40	5	1000	800	175	-40 ... +125	-65 ... +175	6 10 16	40 ² / ₂ 60 ² / ₂ 100 ² / ₂	100 ² / ₂ 160 ² / ₂ 250 ² / ₂
BC 337	50	45	5	800	500	150	-25 ... +85	-55 ... +150	10 16 25	60 ⁴ / ₄ 100 ⁴ / ₄ 160 ⁴ / ₄	160 ⁴ / ₄ 250 ⁴ / ₄ 400 ⁴ / ₄
BC 338	30	25	5	800	500	150	-25 ... +85	-55 ... +150	10 16 25	60 ⁴ / ₄ 100 ⁴ / ₄ 160 ⁴ / ₄	160 ⁴ / ₄ 250 ⁴ / ₄ 400 ⁴ / ₄
BC 393	180	180	6	100	400	200	-40 ... +125	-55 ... +200		50 ⁵ / ₅	
BC 413	45	30	5	100	300	150	-25 ... +125	-55 ... +150	B C	200 400	480 850
BC 414	50	45	5	100	300	150	-25 ... +125	-55 ... +150	B C	200 400	480 850
BC 527	45	45	5	50	300	150	-25 ... +85	-55 ... +150	I II III	90 180 360	240 450 850
BC 528	20	20	5	50	300	150	-25 ... +85	-55 ... +150	I II III	90 180 360	240 480 850
BC 627	45	45	5	50	300	150	-25 ... +85	-55 ... +150	A B C		/180/ /290/ /520/
BC 628	20	20	5	50	300	150	-25 ... +85	-55 ... +150	A B C		/180/ /290/ /520/
BCE 107 BCE 107 R	45	45	5	100	150	175	-40 ... +125	-55 ... +175	A B		/180/ /290/

	12		13	14	15	16	17	18	19	20
100 ^{2/} 160 ^{2/} 150 ^{2/}			50	25	/10/	1 ^{3/}		N	e	CE 23
240 180	125 240	260 500	150	4,5	10	0,25	10	N	d	CE 35
240 180 300	125 240 450	260 500 900	150	4,5	10	0,25	10	N	d	CE 35
180 300	240 450	500 900	150	4,5	10	0,25	4	N	b	CE 35
150 240	75 125	150 260	100	6	10	0,2	10	P	a	CE 35
150 240 480	75 125 240	150 260 500	100	6	10	0,2	10	P	a	CE 35
240 480	125 240	260 500	100	6	10	0,2	4	P	b	CE 35
100 ^{2/} 160 ^{2/} 250 ^{2/}			50	30	/10/	1 ^{3/}		P	e	CE 23
160 ^{4/} 250 ^{4/} 400 ^{4/}			/150/	/7/	/10/	0,7 ^{1/}		N	e	CE 35
160 ^{4/} 250 ^{4/} 400 ^{4/}			/150/	/7/	/10/	0,7 ^{1/}		N	e	CE 35
			50	7	10	/0,25/		P	e	CE 22
480 850	240 450	500 900	/250/	/2,5/	10	0,25	2,5	N	b	CE 35
480 850	240 450	500 900	/250/	/2,5/	10	0,25	2,5	N	b	CE 35
240 450 850	100 210 400	240 450 900	150	4,5	5	0,25	10	N	e	CE 22
240 480 850	100 210 400	240 450 900	150	4,5	5	0,25	10	N	e	CE 22
	100 210 400	240 450 900	150	4,5	5	0,25	10	N	e	CE 35
	100 210 400	240 450 900	150	4,5	5	0,25	10	N	e	CE 35
	125 240	260 500	150	6	10	0,25	10	N	d	CE 45

1	2	3	4	5	6	7	8	9	10	
BCE 108 DCE 108 R	20	20	5	100	150	175	-40 ... +125	-55 ... +175	A B C	
BCE 109 BCE 109 R	20	20	5	100	150	175	-40 ... +125	-55 ... +175	B C	
BCE 177 BCE 177 R	50	45	5	100	150	175	-40 ... +125	-55 ... +175	VI A B	65 110 200
BCE 178 BCE 178 R	30	25	5	100	150	175	-40 ... +125	-55 ... +175	VI A B C	65 110 200 400
BCE 179 BCE 179 R	25	20	5	100	150	175	-40 ... +125	-55 ... +175	B C	200 400
BCW 29 BCW 29 R	30	20	5	100	200	150	-40 ... +125	-55 ... +150		120
BCW 30 BCW 30 R	30	20	5	100	200	150	-40 ... +125	-55 ... +150		260
BCW 31 BCW 31 R	30	20	5	100	200	150	-40 ... +125	-55 ... +150		110
BCW 32 BCW 32 R	30	20	5	100	200	150	-40 ... +125	-55 ... +150		200
BCW 33 BCW 33 R	30	20	5	100	200	150	-40 ... +125	-55 ... +150		420
BCW 69 BCW 69 R	50	45	5	100	200	150	-40 ... +125	-55 ... +150		120
BCW 70 BCW 70 R	50	45	5	100	200	150	-40 ... +125	-55 ... +150		260
BCW 71 BCW 71 R	50	45	5	100	200	150	-40 ... +125	-55 ... +150		110
BCW 72 BCW 72 R	50	45	5	100	200	150	-40 ... +125	-55 ... +150		200
BCX 17 ^x BCX 17 R ^x		45	5	1000	310	150	-40 ... +125	-65 ... +150		100 ^{4/}
BCX 18 ^x BCX 18 R ^x		25	5	1000	310	150	-40 ... +125	-65 ... +150		100 ^{4/}
BCX 19 ^x BCX 19 R ^x		45	5	1000	310	150	-40 ... +125	-65 ... +150		100 ^{4/}
BCX 20 ^x BCX 20 R ^x		25	5	1000	310	150	-40 ... +125	-65 ... +150		100 ^{4/}

a stopnie wejściowe małej częstotliwości; b stopnie małej częstotliwości niskoszumowe
e stopnie sterujące i wyjściowe średniej mocy

1/ przy $I_C = 0,5 \text{ A}$; $I_B = 0,05 \text{ A}$; 2/ przy $I_C = 150 \text{ mA}$; $U_{CE} = 2 \text{ V}$; 3/ przy $I_C = 1 \text{ A}$;

x nowe uruchomienia

11		12		13	14	15	16	17	18	19	20
	/180/ /290/ /520/	125 240 450	260 500 900	150	6	10	0,25	10	N	d	CE 45
	/290/ /520/	240 450	500 900	150	6	10	0,25	4	N	d	CE 45
65 110 200	150 240 480	75 125 240	150 260 500	/250/	6	10	0,2	10	P	d	CE 45
65 110 200 400	150 240 480 850	75 125 240 450	150 260 500 900	/250/	6	10	0,2	10	P	d	CE 45
200 400	430 850	240 450	500 900	/250/	6	10	0,2	4	P	d	CE 45
120	215			/150/	7	10	0,3	10	P	d	CE 46
260	500			/150/	7	10	0,3	10	P	d	CE 46
110	220			/300/	4	10	0,25	10	N	d	CE 46
200	450			/300/	4	10	0,25	10	N	d	CE 46
420	800			/300/	4	10	0,25	10	N	d	CE 46
120	215			/150/	7	10	0,3	10	P	d	CE 46
260	500			/150/	7	10	0,3	10	P	d	CE 46
110	220			/300/	4	10	0,25	10	N	d	CE 46
200	450			/300/	4	10	0,25	10	N	d	CE 46
100 ^{4/}	600 ^{4/}			100	8	10	0,6 ^{1/}		P	d	CE 46
100 ^{4/}	600 ^{4/}			100	8	10	0,6 ^{1/}		P	d	CE 46
100 ^{4/}	600 ^{4/}			200	5	10	0,6 ^{1/}		N	d	CE 46
100 ^{4/}	600 ^{4/}			200	5	10	0,6 ^{1/}		N	d	CE 46

szumowe; c stopnie wejściowe i sterujące małej częstotliwości; d układy hybrydowe;

1 A; $I_B = 0,1 A$; ^{4/} przy $I_C = 100 mA$; $U_{CL} = 1 V$ ^{5/} przy $I_C = 10 mA$; $U_{CE} = 10 V$

2.2. Tranzystory małej częstotliwości małej mocy specjalne

Oznaczenie wyrobu	Parametry graniczne / t _{amb} = 25°C/						Parametry charakterystyczne / t _{amb} = 25°C/										M	Zastosowanie	Obudowa
	U _{CEO}	U _{CE0}	U _{EBO}	I _C	P _{tot}	t _j	h _{21E}	h _{21E}	f _T	C _{CEO}	U _{CB}	U _{CE}	U _{CE sat}	P	dB				
	V	V	V	mA	mW	°C										U _{CE} = 5 V I _C = 2 mA			
	max	max	max	max	max	max	/typ/	min	max	min	max	min	max	max	max				
1	2	3	4	5	6	7	9	10	11	12	13	14	15	16	17	18			
BCAE 07 BCAE 07 R	45	45	5	100	150	175	/180/ /290/	125 240 500	150	6	10	0,25	10	N	d	CE 45			
BCAE 08 BCAE 08 R	20	20	5	100	150	175	/180/ /290/ /520/	125 240 450 900	150	6	10	0,25	10	N	d	CE 45			
BCAE 09 BCAE 09 R	20	20	5	100	150	175	/290/ /520/	240 450 900	150	6	10	0,25	4	N	d	CE 45			
BCAE 77 BCAE 77 R	50	45	5	100	150	175	65 110 200	150 240 480	/250/	6	10	0,2	10	P	d	CE 45			
BCAE 78 BCAE 78 R	30	25	5	100	150	175	65 110 200 400	150 240 480 850	/250/	6	10	0,2	10	P	d	CE 45			
BCAE 79 BCAE 79 R	25	20	5	100	150	175	200 400	480 850	/250/	6	10	0,2	4	P	d	CE 45			
BCAP 07	45	45	5	100	300	175	110 200	240 480	150	4,5	10	0,20	10	N	e	CE 22			
BCAP 08	20	20	5	100	300	175	110 200 400	240 480 850	150	4,5	10	0,20	10	N	e	CE 22			

1	2	3	4	5	6	7	8	9			10		11	12	13	14	15	16	17	18
BCAP 09	20	20	5	100	300	175	B C	200 400	480 850	240 450	500 900	150	4,5	10	C,20	4	N	f	CE 22	
BCAP 11	80	40	5	1000	800	175	6 10 16	40 ² / ₂ 60 ² / ₂ 100 ² / ₂	100 ² / ₂ 160 ² / ₂ 250 ² / ₂	50	25	50	/10/	1 ¹ / ₁		N	e	CE 23		
BCAP 11 A	100	60	5	1000	800	175	6 ¹ / ₁ 10 16	40 ² / ₂ 60 ² / ₂ 100 ² / ₂	100 ² / ₂ 160 ² / ₂ 250 ² / ₂	50	25	50	/10/	1 ¹ / ₁		N	e	CE 23		
BCAP 13	60	40	5	1000	800	175	6 10 16	40 ² / ₂ 60 ² / ₂ 100 ² / ₂	100 ² / ₂ 160 ² / ₂ 250 ² / ₂	50	30	50	/10/	1 ¹ / ₁		P	e	CE 23		
BCAP 77	50	45	5	100	300	175	VI A B	65 110 200	150 240 480	75 125 240	150 260 500	/100/	7	10	0,2	10	P	e	CE 22	
BCAP 78	30	25	5	100	300	175	VI A B	65 110 200	150 240 480	75 125 240	150 260 500	/100/	7	10	0,2	10	P	e	CE 22	
BCAP 79	25	20	5	100	300	175	A B	110 200	240 480	125 240	260 500	/100/	7	10	0,2	4	P	f	CE 22	
BCAP 93	180	180	6	100	400	200		50 ³ / ₃		50	7	50	/0,25/			P	e	CE 22		

d układy hybrydowe

e układy wejściowe i sterujące małej częstotliwości

f układy niskosumowe małej częstotliwości

1/ przy $I_D = 0,1 \text{ A}$; $I_C = 1 \text{ A}$ 2/ przy $I_C = 150 \text{ mA}$; $U_{CE} = 2 \text{ V}$ 3/ przy $I_C = 10 \text{ mA}$; $U_{CE} = 10 \text{ V}$

2.3. Tranzystory małej częstotliwości dużej mocy

Oznaczenie wyrobu	Parametry graniczne / $t_{amb} = 25^{\circ}C$ /									Grupa
	U_{CBO}	U_{CEO}	U_{EBO}	I_C	P_{tot} przy	t_{case}	t_j	t_{amb}	t_{stg}	
	V	V	V	A	W	$^{\circ}C$	$^{\circ}C$	$^{\circ}C$	$^{\circ}C$	
	max	max	max	max	max		max			
1	2	3	4	5	6	7	8	9	10	11
BD 135	45	45	5	0,5	6,5	60	125	-40 ... +100	-55 ... +125	A B C
BD 136	45	45	5	0,5	6,5	60	125	-40 ... +100	-55 ... +125	
BD 137	60	60	5	0,5	6,5	60	125	-40 ... +100	-55 ... +125	
BD 138	60	60	5	0,5	6,5	60	125	-40 ... +100	-55 ... +125	
BD 139	80	80	5	0,5	6,5	60	125	-40 ... +100	-55 ... +125	
BD 140	80	80	5	0,5	6,5	60	125	-40 ... +100	-55 ... +125	
BD 354	60	40	5	3	12,5	45	175	-25 ... +85	-55 ... +175	
BD 355	60	40	5	3	12,5	45	175	-25 ... +85	-55 ... +175	
BD 643	45	45	5	8	62,5	25	150	-40 ... +100	-40 ... +150	
BD 644 ^x	45	45	5	8	62,5	25	150	-40 ... +100	-40 ... +150	
BD 645	60	60	5	8	62,5	25	150	-40 ... +100	-40 ... +150	
BD 646 ^x	60	60	5	8	62,5	25	150	-40 ... +100	-40 ... +150	
BD 647	80	80	5	8	62,5	25	150	-40 ... +100	-40 ... +150	
BD 648 ^x	80	80	5	8	62,5	25	150	-40 ... +100	-40 ... +150	
BD 649	100	100	5	8	62,5	25	150	-40 ... +100	-40 ... +150	
BD 650 ^x	100	100	5	8	62,5	25	150	-40 ... +100	-40 ... +150	
BDP 279	30	25	3	7	40	25	150	-40 ... +100	-40 ... +150	
BDP 280	30	25	3	7	40	25	150	-40 ... +100	-40 ... +150	
BDP 281	40	30	5	7	40	25	150	-40 ... +100	-40 ... +150	
BDP 282	40	30	5	7	40	25	150	-40 ... +100	-40 ... +150	

Grupa	Parametry charakterystyczne / $t_{amb} = 25^{\circ}C$ /								N n-p-n P p-n-p	Zasto- sowa- nie	Obu- dowa											
	h_{21E} przy		I_C	U_{CE}	f_T	C_{CBO} przy		$U_{CE\ sat}$ przy				I_C/I_B										
	min	max	A	V	MHz	pF	V	V				A/A										
				min /typ/	max /typ/		max															
11	12		13	14	15	16	17	18	19	20	21	22										
A P C	40	250	0,15	2	/200/			0,5	0,5/0,05	N	b	CE 39										
	40	250	0,15	2	/150/			0,5	0,5/0,05	P	b	CE 39										
	40	160	0,15	2	/200/			0,5	0,5/0,05	N	b	CE 39										
	40	160	0,15	2	/150/			0,5	0,5/0,05	P	b	CE 39										
	40	160	0,15	2	/200/			0,5	0,5/0,05	N	b	CE 39										
	40	160	0,15	2	/150/			0,5	0,5/0,05	P	b	CE 39										
A B C	30	90	1	2	10			0,75	2/0,2	N	a	CE 24										
	50	150																				
	100	300																				
A B C	30	90	1	2	10			0,75	2/0,2	P	a	CE 24										
	50	150																				
	100	300																				
	750												3	3	1	/100/	10	2	3/0,012	N	a	CE 30
	750												3	3	1	/100/	10	2	3/0,012	P	a	CE 30
	750												3	3	1	/100/	10	2	3/0,012	N	a	CE 30
	750												3	3	1	/100/	10	2	3/0,012	P	a	CE 30
	750												3	3	1	/100/	10	2	3/0,012	N	a	CE 30
	750												3	3	1	/100/	10	2	3/0,012	P	a	CE 30
	750												3	3	1	/100/	10	2	3/0,012	N	a	CE 30
	750												3	3	1	/100/	10	2	3/0,012	P	a	CE 30
	25												1	4	3	250	10	3,5	7/3	N	c	CE 30
	25												1	4	8	250	10	3,5	7/3	P	c	CE 30
	30	200											3	4	4	250	10	3,5	7/3	N	c	CE 30
30	200	3	4	10	250	10	3,5	7/3	P	c	CE 30											

1	2	3	4	5	6	7	8	9	10	11	12	
BDP 283	60	50	5	7	40	25	150	-40 ... +100	-40 ... +150		30	200
BDP 284	60	50	5	7	40	25	150	-40 ... +100	-40 ... +150		30	200
BDP 285	80	70	5	7	40	25	150	-40 ... +100	-40 ... +150		30	200
BDP 286	80	70	5	7	40	25	150	-40 ... +100	-40 ... +150		30	200
BDP 391	50	40	5	15	75	25	150	-40 ... +100	-40 ... +150		20	150
BDP 392	50	40	5	15	75	25	150	-40 ... +100	-40 ... +150		20	150
BDP 393	70	60	5	15	75	25	150	-40 ... +100	-40 ... +150		20	150
BDP 394	70	60	5	15	75	25	150	-40 ... +100	-40 ... +150		20	150
BDP 395	90	80	5	15	75	25	150	-40 ... +100	-40 ... +150		20	150
BDP 396	90	80	5	15	75	25	150	-40 ... +100	-40 ... +150		20	150
BDP 491 ^x	50	40	5	15	125	25	200	-40 ... +150	-40 ... +200		20	
BDP 492 ^x	50	40	5	15	125	25	200	-40 ... +150	-40 ... +200		20	
BDP 493 ^x	70	60	5	15	125	25	200	-40 ... +150	-40 ... +200		20	
BDP 494 ^x	70	60	5	15	125	25	200	-40 ... +150	-40 ... +200		20	
BDP 495 ^x	90	80	5	15	125	25	200	-40 ... +150	-40 ... +200		20	
BDP 496 ^x	90	80	5	15	125	25	200	-40 ... +150	-40 ... +200		20	
BDY 23	60	60	10	6	87,5	25	200	-40 ... +100	-55 ... +175	A B C	15 30 75	45 90 180
BDY 24	100	90	10	6	87,5	75	200	-40 ... +100	-55 ... +175	A B C	15 30 75	45 90 180
BDY 25	200	140	10	6	87,5	25	200	-40 ... +100	-55 ... +175	A B C	15 30 75	45 90 180

a stopnie mocy, przełączniki mocy
b stopnie sterujące średniej mocy, komplementarne
c przełączniki mocy, stopnie mocy, stabilizatory

^x nowe uruchomienia

	13	14	15	16	17	18	19	20	21	22
200	2,5	4	4	250	10	3,5	7/3	N	c	CE 30
200	2,5	4	10	250	10	3,5	7/3	P	c	CE 30
200	2	4	4	250	10	3,5	7/3	N	c	CE 30
200	2	4	10	250	10	3,5	7/3	P	c	CE 30
150	5	4	4			1,3	5/0,5	N	a	CE 30
150	5	4	4			1,3	5/0,5	P	a	CE 30
150	5	4	4			1,3	5/0,5	N	a	CE 30
150	5	4	4			1,3	5/0,5	P	a	CE 30
150	5	4	4			1,3	5/0,5	N	a	CE 30
150	5	4	4			1,3	5/0,5	P	a	CE 30
	5	4	5			1,3	5/0,5	N	a	CE 20
	5	4	5			1,3	5/0,5	P	a	CE 20
	5	4	5			1,3	5/0,5	N	a	CE 20
	5	4	5			1,3	5/0,5	P	a	CE 20
	5	4	5			1,3	5/0,5	N	a	CE 20
	5	4	5			1,3	5/0,5	P	a	CE 20
45 90 180	2	4	10			1	2/0,25	N	c	CE 20
45 90 180	2	4	10			0,6	2/0,25	N	c	CE 20
45 90 180	2	4	10			0,6	2/0,25	N	c	CE 20

2.4. Tranzystory malej częstotliwości dużej mocy specjalne

BD spec

Oznaczenie wyrobu	Parametry graniczne / $t_{amb} = 25^{\circ}C/$						Parametry charakterystyczne / $t_{amb} = 25^{\circ}C/$										Zastosowanie	Obudowa	
	U _{CEO}	U _{CEO}	U _{EBO}	I _C	P _{tot} przy t _{case}	t _j	h _{21E} przy		f _T	C _{CEO} przy		U _{CE sat} przy	I _C /I _B	N	P	P			P
							min	max		U _{CB}	U _{CB}								
	V	max	V	A	W	°C	max	max	MHz	min /typ/	max	V	max	max	max	max			max
2	3	4	5	6	7	8	9	10	11	12	13	14	15	16	17	18	19		
BDAP 35	45	45	5	0,5	6,5	60	125	40	250	0,15	/200/		0,5	0,5/0,05	N		b	CE 39	
BDAP 36	45	45	5	0,5	6,5	60	125	40	250	0,15	/150/		0,5	0,5/0,05	P		b	CE 39	
BDAP 37	60	60	5	0,5	6,5	60	125	40	160	0,15	/200/		0,5	0,5/0,05	N		b	CE 39	
BDAP 38	60	60	5	0,5	6,5	60	125	40	160	0,15	/150/		0,5	0,5/0,05	P		b	CE 39	
BDAP 39	80	80	5	0,5	6,5	60	125	40	160	0,15	/200/		0,5	0,5/0,05	N		b	CE 39	
BDAP 40	80	80	5	0,5	6,5	60	125	40	160	0,15	/150/		0,5	0,5/0,05	P		b	CE 39	
BDAP 54	60	40	5	3	12,5	45	175	30	90	1	30	70	0,75	2/0,2	N		a	CE 24	
BDAP 55	60	40	5	3	12,5	45	175	30	90	1	30	70	1,0	2/0,2	P		a	CE 24	
BDAP 81	40	30	5	7	40	25	150	30	200	3	4	250	3,5	7/3	N		c	CE 30	
BDAP 82	40	30	5	7	40	25	150	30	200	3	10	250	3,5	7/3	P		c	CE 30	
BDAP 83	60	50	5	7	40	25	150	30	200	2,5	4	250	3,5	7/3	N		c	CI 30	
BDAP 84	60	50	5	7	40	25	150	30	200	2,5	10	250	3,5	7/3	P		c	CE 30	
BDAP 85	80	70	5	7	40	25	150	30	200	2	4	250	3,5	7/3	N		c	CE 30	

1	2	3	4	5	6	7	8	9	10	11	12	13	14	15	16	17	18	19	
BDAP 86	80	70	5	7	40	25	150		30	200	2	10	250	10	3,5	7/3	P	c	CE 30
BDAP 91 ^x	50	40	5	15	125	25	200		20		5	5			1,3	5/0,5	N	a	CI 20
BDAP 92 ^x	50	40	5	15	125	25	200		20		5	5			1,3	5/0,5	P	a	CE 20
BDAP 93 ^x	70	60	5	15	125	25	200		20		5	5			1,3	5/0,5	N	a	CE 20
BDAP 94 ^x	70	60	5	15	125	25	200		20		5	5			1,3	5/0,5	P	a	CE 20
BDAP 95 ^x	90	80	5	15	125	25	200		20		5	5			1,3	5/0,5	N	a	CE 20
BDAP 96 ^x	90	80	5	15	125	25	200		20		5	5			1,3	5/0,5	P	a	CE 20
BDCP 25	200	140	10	6	87,5	25	200	A L C	15 30 75	45 90 180	2	10			0,6	2/0,25	N	c	CI 20

a stopnie mocy, przełączniki mocy

b stopnie sterujące średniej mocy, komplementarne

c przełączniki mocy, stopnie mocy, stabilizatory

x nowe uruchomienia

2.5. Tranzystory wielkiej częstotliwości

Oznaczenie wyrobu	Parametry graniczne / $t_{amb} = 25^{\circ}C$ /								Grupa	h_{21E} prz	
	U_{CBO}	U_{CEO}	U_{EBO}	I_C	P_{tot}	t_j	t_{amb}	t_{stg}		min	max
	V	V	V	mA	mW	$^{\circ}C$	$^{\circ}C$	$^{\circ}C$			
	max	max	max	max	max	max					
1	2	3	4	5	6	7	8	9	10	11	
BF 167	40	30	4	25	150	175	-40 ... +125	-65 ... +175		25	
BF 173	40	25	4	25	230	175	-40 ... +125	-65 ... +175		40	
BF 180	30	20	3	20	150	175	-40 ... +125	-55 ... +175		15	
BF 181	30	20	3	20	150	175	-40 ... +125	-55 ... +175		20	
BF 182	30	20	3	20	150	175	-40 ... +125	-85 ... +175		10	
BF 183	30	20	3	20	150	175	-40 ... +125	-85 ... +175		10	
BF 194	30	20	4	30	160	125	-40 ... +125	-65 ... +125		67	225
BF 195	30	20	4	30	160	125	-40 ... +125	-65 ... +125		35	125
BF 196	40	30	4	25	160	125	-40 ... +125	-65 ... +125		30	
BF 197	40	25	4	25	250	125	-40 ... +125	-65 ... +125		40	
BF 200	30	20	3	20	150	175	-40 ... +125	-55 ... +175		15	
BF 214	30	30	4	30	165	175	-40 ... +125	-55 ... +175		90	330
BF 215	30	30	4	30	165	175	-40 ... +125	-55 ... +175		40	165
BF 240	40	40	4	25	300	150	-25 ... +85	-55 ... +150		67	220
BF 241	40	40	4	25	300	150	-25 ... +85	-55 ... +150		36	125
BF 257	160	160	5	100	5 W ^{1/}	175	-40 ... +125	-55 ... +175		25	
BF 258	250	250	5	100	5 W ^{1/}	175	-40 ... +125	-55 ... +175		25	
BF 259	300	300	5	100	5 W ^{1/}	175	-40 ... +125	-55 ... +175		25	
BF 314	30	30	4	25	300 ^{2/}	150	-25 ... +85	-55 ... +150		29	
BF 414 ^x	40	30	4	25	300 ^{2/}	150	-40 ... +125	-55 ... +150		30	
BF 440 ^x	40	40	4	25	300 ^{2/}	150	-40 ... +125	-55 ... +150		60	220
BF 441 ^x	40	40	4	25	300 ^{2/}	150	-40 ... +125	-55 ... +150		30	120

Parametry charakterystyczne / $t_{amb} = 25^{\circ}C$ /

21E przy		f_T		C_{12es} przy		r_{bb}, C_c przy			F przy				N n-p-n P p-n-p	Za- sto- so- wa- nie	Obu- dowa
U_{CE}	I_C	f_T	C_{12es}	r_{bb}, C_c	F	U_{CE}	I_C	f_p	N	Za- sto- so- wa- nie	Obu- dowa				
V	mA	MHz	pF	ps	dB	V	mA	MHz							
max		min /typ/	max	max	typ										
11	12	13	14	15	16	17	18	19	20	21	22	23	24	25	26
	10	4	250	0,25	10	12	4	10					N	a	CE 25
	10	7	350	0,3	10	10	7	10					N	a	CE 25
	10	2	500	0,4	10	4	2	10	8	10	2	800	N	e	CE 25
	10	2	400	0,4	10	4	2	10					N	h	CE 25
	10	2	550	0,5	10	6	2	10					N	e	CE 25
	10	2	550	0,5	10	6	3	10					N	e	CE 25
225	10	1	150	1	10	17	5	10	1,5	10	1	0,2	N	d	CE 36
125	10	1	150	1	10	11	5	10	4	10	1	100	N	d	CE 36
	10	4	250	0,3	10	12	4	10					N	a	CE 36
	10	7	350	0,35	10	10	7	10					N	a	CE 36
	10	2	400	0,4	10	6	2	10	5	10	2	200	N	e	CE 25
330	10	1	250	0,7	10	12	1	10	3,5	10	1	1	N	d	CE 25
165	10	1	150	0,7	10	15	1	10	3,5	10	1	1	N	d	CE 25
220	10	1	/430/	0,34	/10/				4	/10/	1	0,3	N	d	CE 35
125	10	1	/400/	0,34	/10/				4	/10/	1	0,3	N	d	CE 35
	10	30	40										N	g	CE 23
	10	30	40										N	g	CE 23
	10	30	30										N	g	CE 23
	10	4	/450/	0,13	/10/				4	/10/	1	100	N	d	CE 35
	10	1	/400/						2	/10/	1	100	P	d	CE 35
220	10	1	/250/	0,4	/10/				3	/10/	1	0,3	P	d	CE 35
125	10	1	/250/	0,4	/10/				3	/10/	1	0,3	P	d	CE 35

1	2	3	4	5	6	7	8	9	10	11		12	13
BF 457	160	160	5	100	1,2 W	150	-40 ... +100	-55 ... +150		25		10	30
BF 458	250	250	5	100	1,2 W	150	-40 ... +100	-55 ... +150		25		10	30
BF 459	300	300	5	100	1,2 W	150	-40 ... +100	-55 ... +150		25		10	30
BF 469 ^x	250	250	5	30	1,25 W	150	-40 ... +100	-55 ... +150		50		20	25
BF 470 ^x	250	250	5	30	1,25 W	150	-40 ... +100	-55 ... +150		50		20	25
BF 519	70	50	5	50	300	150	-40 ... +125	-55 ... +175	II III V VI	20 30 70 150	35 90 170	6	10
BF 520	50	30	5	50	300	150	-40 ... +125	-55 ... +175	II III V	20 30 70	35 90 170	6	10
BF 521	30	15	5	50	300	150	-40 ... +125	-55 ... +175	II III V VI	20 30 70 150	35 90 170	6	10
DF 619	70	50	5	50	300	150	-25 ... +85	-55 ... +150	A B C D	20 30 70 150	35 90 170	6	10
BF 620	50	30	5	50	300	150	-25 ... +85	-55 ... +150	A B C D	20 30 70 150	35 90 170	6	10
BF 621	30	15	5	50	300	150	-25 ... +85	-55 ... +150	A B C D	20 30 70 150	35 90 170	6	10
BFE 214 ^x BFE 214R ^x	30	30	4	30	150	175	-40 ... +125	-55 ... +175		90	330	10	1
BFE 215 ^x BFE 215R ^x	30	30	4	30	150	175	-40 ... +125	-55 ... +175		35	165	10	1
BFS 18 ^x BFS 18R ^x	30	20	5	30	200	150	-40 ... +125	-55 ... +150		35	125	10	1
BFS 19 ^x BFS 19R ^x	30	20	5	30	200	150	-40 ... +125	-55 ... +150		65	225	10	1

a pośrednia TV

b uniwersalne

c układy hybrydowe

d głowice VHF, pośrednia AM/FM

e wzmacniacze UHF

g układy wysokonapięciowe małej mocy

h wzmacniacze UHF

x nowe uruchomienia

1/

2/

13	14	15	16	17	18	19	20	21	22	23	24	25	26
30	/60/	/4,5/	30								N	g	CE 39
30	/60/	/4,5/	30								N	g	CE 39
30	/60/	/4,5/	30								N	g	CE 39
25	60	/1,8/	/30/	90	10	/20/					N	g	CE 39
25	60	/1,8/	/30/	90	10	/20/					P	g	CE 39
10	150	/8/	/10/	500	5	/10/					N	b	CE 22
10	150	/8/	/10/	500	5	/10/					N	b	CE 22
10	150	/8/	/10/	500	5	/10/					N	b	CE 22
10	150	/6/	/10/	500	5	/10/					N	b	CE 35
10	150	/6/	/10/	500	5	/10/					N	b	CE 35
10	150	/6/	/10/	500	5	/10/					N	b	CE 35
1	150	1	10	22	1	10	3,5	10	1	100	N	c	CE 45
1	150	1	10	15	1	10	3,5	10	1	100	N	c	CE 45
1	/200/	0,85	10				4	10	1	100	N	c	CE 46
1	/260/	0,85	10				4	10	1	100	N	c	CE 46

1/ przy $t_{case} \leq 60^{\circ}C$

2/ przy $t_{amb} \leq 45^{\circ}C$

2.6. Tranzystory wielkiej częstotliwości specjalne

Oznaczenie wyrobu	Parametry graniczne / $t_{amb} = 25^{\circ}C$ /						Parametry				
	U_{CBO}	U_{CEO}	U_{EBO}	I_C	P_{tot}	t_j	h_{21L} przy		f_T	C_{12es}	
	V	V	V	mA	mW	$^{\circ}C$	I_C		MHz	pF	
	max	max	max	max	max	max	min	max	min	max	
1	2	3	4	5	6	7	8		9	10	11
BFAP 15	30	30	4	30	165	175	40	165	1	150	0,7
BFAP 57	160	160	5	100	5 W ^{1/}	175	25		30	40	
BFAP 58	250	250	5	100	5 W ^{1/}	175	25		30	40	
BFAP 59	300	300	5	100	5 W ^{1/}	175	25		30	40	
BFAP 80	30	20	3	20	150	175	15		2	500	0,4
BFAP 83	30	20	3	20	150	175	10		2	500	0,5

- a główne VHF, pośrednia AM/FM
 b wzmacniacze VHF
 d układy wysokonapięciowe

1/ przy $t_{case} \leq 60^{\circ}C$

2.7. Tranzystory polowe złączone (FET): kanał n

Ozna- czenie wyrobu	Parametry graniczne / $t_{amb} = 25^{\circ}C$ /							Gru- pa	I_{DSS} przy				
	U_{GD}	U_{DS}	I_G	P_{tot}	t_j	t_{amb}	t_{stg}		I_{DSS} przy		U_{GS}	U_{DS}	
	V	V	mA	mW	$^{\circ}C$	$^{\circ}C$	$^{\circ}C$		I_{DSS} przy		V	V	
	max	max	max	max	max				min	max			
1	2	3	4	5	6	7	8	9	10		11	12	
BF 245	30	30	10	360	150	-40 ... +100	-55 ... +150	A B C	2 6 12	6,5 15 25	0	15	-0, -1, -3,
BFR 30 ^x	25	25	5	200	150	-40 ... +125	-65 ... +150		4	10	0	10	
BFR 31 ^x	25	25	5	200	150	-40 ... +125	-65 ... +150		1	5	0	10	

c układy hybrydowe

f wzmacniacze niskoszumowe

x nowe uruchomienia'

BF spec

Parametry charakterystyczne / $t_{amb} = 25^{\circ}C$ /								N n-p-n p p-n-p	Zasto- sowa- nie	Obudowa
C_{12es} przy		r_{bb}, C_c przy		F przy						
U_{CE}		I_C		U_{CL}	I_C	f_p				
pF	V	ps	mA	dB	V	mA	MHz			
max		max		max						
11	12	13	14	15	16	17	18	19	20	21
0,7	10	15	1	3,5	10	1	100	N	a	CE 25
								N	d	CE 23
								N	d	CE 23
								N	d	CE 23
0,4	10	4	2	7	10	2	800	N	b	CE 25
0,5	10	6	3					N	b	CE 25

BF FET

Parametry charakterystyczne / $t_{amb} = 25^{\circ}C$ /												Zasto- sowa- nie	Obu- dowa		
U_{DS}	U_{GS} przy				U_{GSS} off przy				C_{12es} przy						
	U_{DS}	I_D	U_{DS}	I_D	U_{DS}	I_D	U_{DS}	U_{GS}	f_p						
V	V			V	μA	V		V	nA	pF	V	V	MHz		
	min	/typ/	max			min	max			max					
12	13			14	15	16		17	18	19	20	21	22	23	24
15	-0,4		-2,2	15	200	-0,5	-8	15	10	1,1	20	-1	1	f	CE 35
	-1,6		-3,8												
	-3,2		-7,5												
10		/-4/		10	50					1,5			1	c	CE 46
10		/-2/		10	50					1,5			1	c	CE 46

2.8. Tranzystory przełączające / $t_{amb} = -40^{\circ}C \dots +125^{\circ}C$, $t_{stg} = -65^{\circ}C \dots +150^{\circ}C$ /

Oznaczenie wyrobu	Parametry graniczne / $t_{amb} = 25^{\circ}C$ /						Parametry char							
	U_{CBO}	U_{CEO}	U_{EBO}	I_C	P_{tot}	t_j	h_{21E} przy		f_T	C_{CBO} przy		U_{CE}		
	V	V	V	mA	mW	$^{\circ}C$			MHz	pF	V	mA		
	max	max	max	max	max	max	min	max	min	max				
1	2	3	4	5	6	7	8	9	10	11	12	13	14	
BSV 52 ^x BSV 52R ^x	20	12	5	100	200	150	40	120	1	10	400	4	5	40

^x nowe uruchomienia

2.9. Tranzystory dużej mocy wysokonapięciowe

Oznaczenie wyrobu	Parametry graniczne / $t_{amb} = 25^{\circ}C$ /									
	U_{CBO} / U_{CES} /	U_{CEO}	U_{EBO}	I_C	P_{tot} przy		t_j	t_{amb}	t_{stg}	
	V	V'	V	A	W	t_{case}	$^{\circ}C$	$^{\circ}C$	$^{\circ}C$	min
	max	max	max	max	max		max			
1	2	3	4	5	6	7	8	9	10	
BU 201 ^x	1300	600	5	2,5	10	90	115	-40 ... +100	-65 ... +115	
BU 205 ^x	1500	700	5	2,5	10	90	115	-40 ... +100	-65 ... +115	
BU 206 ^x	1700	800	5	2,5	10	90	115	-40 ... +100	-65 ... +115	
BU 126 ^x	/750/	300	6	3	30	50	125	-65 ... +125	-65 ... +125	15
BU 326 ^x	/800/	375	6	6	60	50	150	-65 ... +125	-65 ... +150	15
BUP 406 ^x	400	200	6	7	60	25	150			
BUP 407 ^x	330	150	6	7	60	25	150			
BUP 323 ^x	500	350	8	10	175	25	200			15
BUYP 52	120	70	5	5	/50/	25	150	-40 ... +100	-40 ... +150	1
BUYP 53	80	50	5	5	/50/	25	150	-40 ... +100	-40 ... +150	2
BUYP 54	40	30	5	5	/50/	25	150	-40 ... +100	-40 ... +150	2

a układy odchylenia poziomego

b układy zapłonowe

c układy przełączające mocy, stabilizatory, wzmacniacze

d zasilacze impulsowe

BS

Parametry charakterystyczne / $t_{amb} = 25^{\circ}C$ /									N n-p-n P p-n-p	Zastosowanie	Obudowa
y	$U_{CE sat}$ przy		t_s przy		t_{on} przy		t_{off} przy				
CB	I_C/I_B		I_C/I_B		I_C/I_B		I_C/I_B				
V	mV	mA	ns	mA	ns	mA	ns	mA			
	max		max		max		max				
13	14	15	16	17	18	19	20	21	22	23	24
5	400	50/5	13	10/10	12	10/3	18	10/3	N	układy hybrydowe	CE 46

BU

Parametry charakterystyczne / $t_{amb} = 25^{\circ}C$ /							N n-p-n	Zastosowanie	Obudowa
h_{21E}		przy		f_T	$U_{CE sat}$ przy				
		I_C	U_{CE}		I_C/I_B				
min	max	A	V	MHz	V	A/A			
				min /typ/	max				
11		12	13	14	15	16	17	18	19
2,0		2	5	/7,5/	5	2/1	N	a	CE 20
2,0		2	5	/7,5/	5	2/1	N	a	CE 20
1,8		2	5	/7,5/	5	2/1	N	a	CE 20
15	60	1	5	6	10	2,5/0,25	N	d	CE 20
15		0,6	5	6	10	2,5/0,25	N	d	CE 20
				10	1	5/0,5	N	a	CE 30
				10	1	5/0,5	N	a	CE 30
150	2000	3	6		1,5	3/0,06	N	b	CE 20
10		0,5	5	10	0,35	0,5/0,05	N	c	CE 20
20		0,5	5	10	0,35	0,5/0,05	N	c	CE 20
20		0,5	5	10	0,35	0,5/0,05	N	c	CE 20

niacze mocy

x nowe uruchomienia

52

2.10. Tranzystory dużej mocy wysokonapięciowe specjalne

BU spec

Oznaczenie wyrobu	Parametry graniczne / $t_{amb} = 25^{\circ}C/$						Parametry charakterystyczne / $t_{amb} = 25^{\circ}C/$						N	Zastosowanie	Ubudowa
	U_{CBO}	U_{CEO}	U_{EBO}	I_C	P_C przy t_{case}	t_j	h_{21E} przy I_C	f_T	$U_{CE sat}$ przy I_C/I_B						
	V	V	V	A	W	$^{\circ}C$		MHZ	V						
	max	max	max	max	max	max	min	min	max						
1	2	3	4	5	6	7	8	9	10	11	12	13	14	15	16
BUCP 52	120	70	5	5	50	25	150	10	0,5	10	2	5/0,5	N	układy przełączające i wzmacniające mocy, stabilizatory	CE 20

2.11. Rysunki obudów

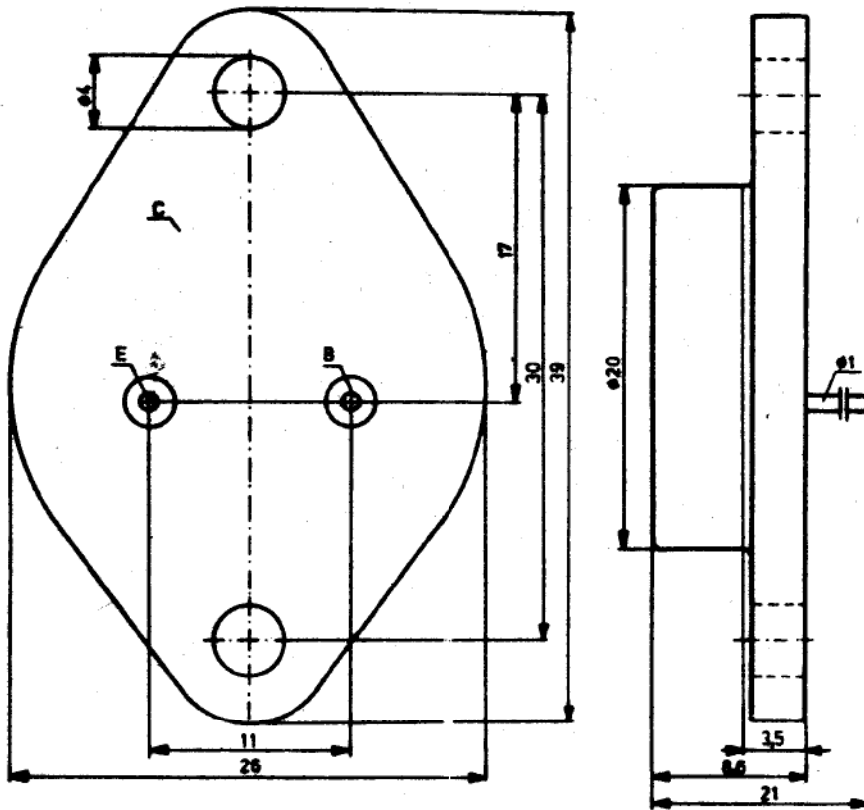

CE 20	TO 3	CB 19
-------	------	-------

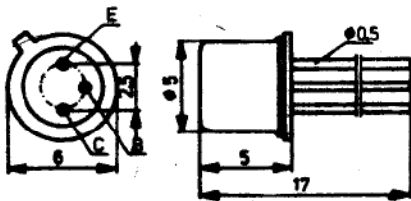

CE 22	TO 18	CB 6
-------	-------	------

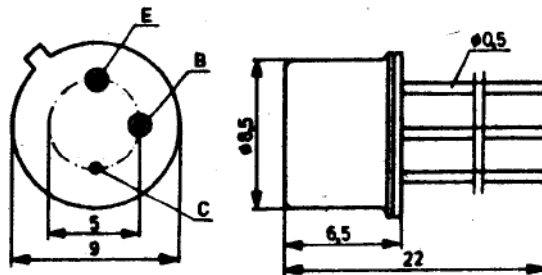

CE 23	TO 39	CB 7
-------	-------	------

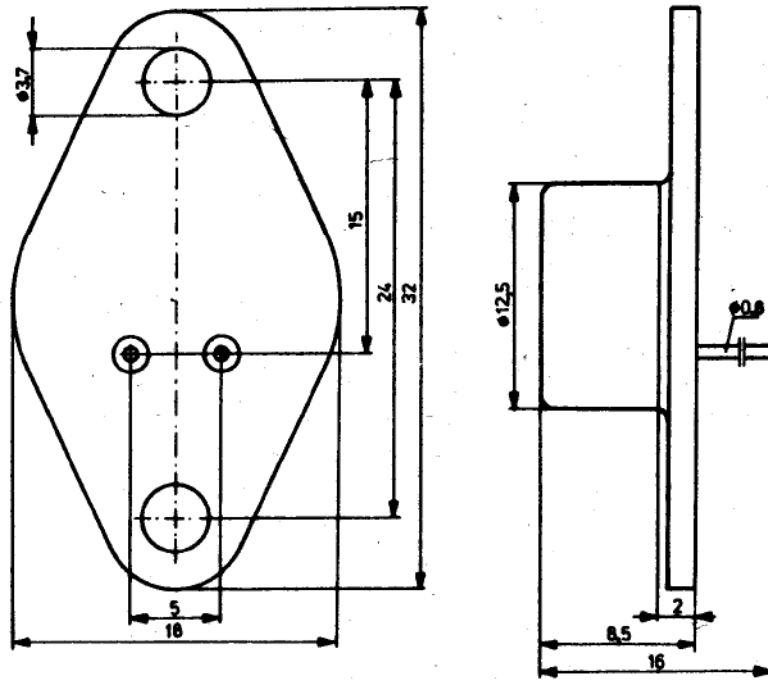

CE 24	TO 66	CB 72
-------	-------	-------

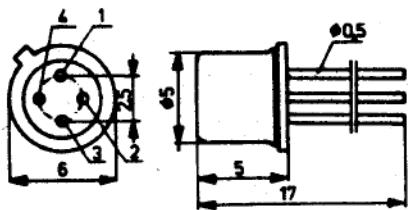

CE 25	TO 72	CB 4
-------	-------	------

	1	2	3	4
BFAP(5, BF167, 173, 214, 215	B	E	C	M
pozostale	E	B	C	M

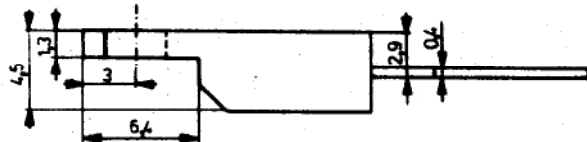
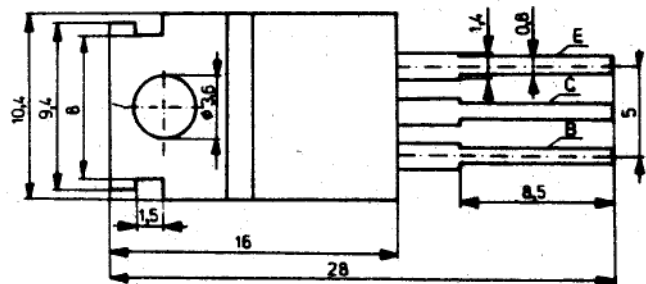

CE 30	TO 220
-------	--------

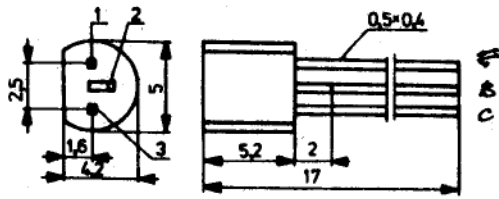

	1	2	3
BF245	D	S	G
BF240-1, BF440-1	B	E	C
pozostałe	E	B	C

CE 35	TO 92	CB 97
-------	-------	-------

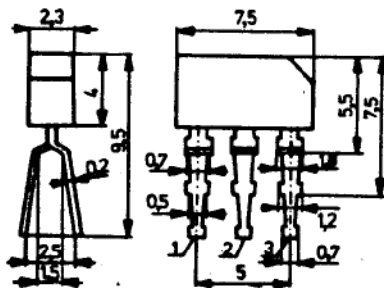

	1	2	3
BF194 - 197	B	E	C
pozostałe	E	B	C

CE 36		CB 13
-------	--	-------

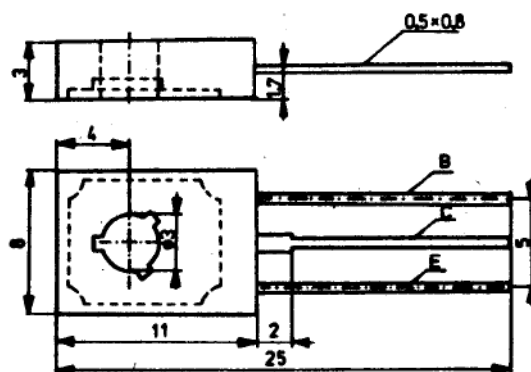

CE 39	TO 126	SOT 32	CB 16
-------	--------	--------	-------

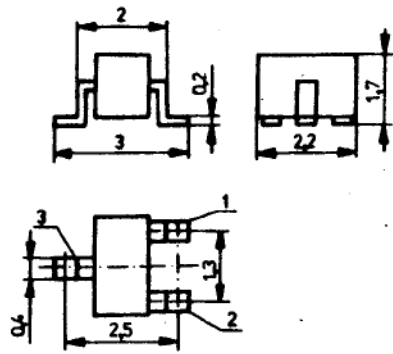

	I	2	3
wersja nom.	B	E	C
wersja R	E	B	C

CE45			

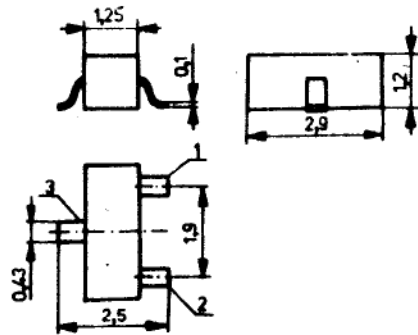

	I	2	3
wersja nom.	E	B	C
wersja R	B	E	C
BFR 30 - 31	S	D	G
BFR 30R-31R	D	S	G

CE46	SOT23